



CONTENTS	PAGE
D-Sub connector system – introduction	05.02
D-Sub Standard connectors (D-Sub – S)	05.04
D-Sub High Density connectors (D-Sub – HD)	05.36
D-Sub Mixed connectors (D-Sub – M)	05.48
D-Sub Filter connectors (D-Sub – F)	05.90
D-Sub Waterproof IP 67 connectors (D-Sub – W)	05.122
D-Sub Housing range (D-Sub – H)	05.146
D-Sub Standard press-in connectors	05.167
D-Sub Standard SMC connectors	05.172
Cables for insulation displacement termination and cable assemblies	05.180

Tooling see chapter 20

In the automation industry, the Subminiature D connectors are the standard interfaces for data, signal and service/programmer interfaces. The extensive HARTING product range allows the set up of all Subminiature D interfaces common in the industry, such as for field buses (PROFIBUS, CanOpen and DeviceNet), while the connectors are also available in optional plastic and metal housings with IP 20 and IP 65 / IP 67 protection.

In addition to the comprehensive range of Standard connectors with 9 to 50 straight, right-angled or US foot print style contacts, HARTING offers other product ranges which extend the application field of Subminiatur D connectors considerably.

Depending on the product family, various termination techniques can be supplied such as press-in, solder, SMC or SMT to match the customer's termination process.

In addition, a wide range of hoods and accessories complete the cable connector range to fulfil all kinds of requirements such as EMC, IP 65 / IP 67 etc.

For the cabling HARTING provides cable assemblies for standard applications like fieldbus, cable or customized solutions.



## D-SUB – MIXED CONNECTORS

with nearly 20 different contact arrangements offering versatile options for mixing power, coaxial, high voltage, signal and even pneumatic contacts in one connector.

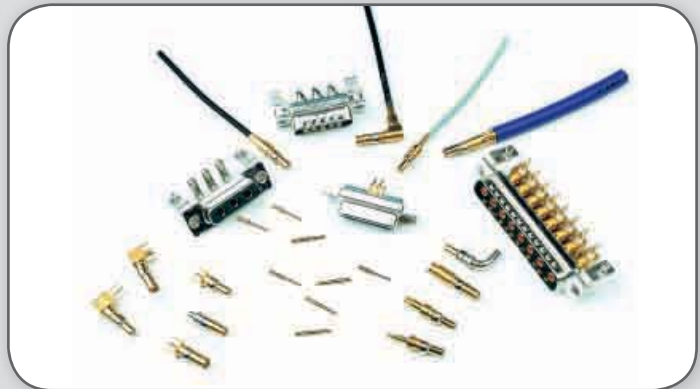

## D-SUB – WATERPROOF

IP 65 / IP 67 connectors with 9 to 50 contacts for panel mount to PCB or cable.



D-Sub

## D-SUB – FILTER CONNECTORS

with 9 to 37 contacts and integrated, different filter designs, like C, L or Pi types.



## D-SUB – HIGH DENSITY CONNECTORS

with 15 to 78 straight and right-angled contacts, exceeding the contact capacity of the standard Subminiature D connectors by 70 %.



Number of contacts 9, 15, 25, 37, 50  
UL recognized

Working current  
see current carrying capacity chart  
Turned contacts 7.5 A max.  
Stamped contacts 6.5 A max.

Test voltage  $U_{r.m.s.}$  1 kV

Clearance and creepage  $\geq 1.0$  mm

Contact resistance  $\leq 10$  m $\Omega$   
Insulation resistance  $\geq 10^{10}$   $\Omega$

Temperature range -55 °C ... + 125 °C  
The higher temperature limit includes the local ambient and heating effect of the contacts under load

Terminations  
a) Solder pins  $\varnothing$  0.6 mm for P.C.B. holes  $\varnothing$  0.8/1 mm  
b) Solder pins, angled 90°  $\varnothing$  0.6 mm for P.C.B. holes  $\varnothing$  1 mm

Materials  
Mouldings and hoods Thermoplastic resin, glass-fibre filled (PBTP), UL 94-V0

Contacts Copper alloy

Contact surface  
Contact zone selectively gold-plated according to performance level<sup>1)</sup>

Metal shell Plated steel

Insertion and withdrawal force  
Connector on P.C.B.  
Solder, straight with clips  
– insertion max. per connector: 60 N  
– withdrawal min. per connector: 10 N

Mating force  
9 way  $\leq 30$  N  
15 way  $\leq 50$  N  
25 way  $\leq 83$  N  
37 way  $\leq 123$  N  
50 way  $\leq 167$  N

### Current carrying capacity

The current carrying capacity is limited by maximum temperature of materials for inserts and contacts including terminals. The current capacity-curve is valid for continuous, not interrupted current-loaded contacts of connectors when simultaneous power on all contacts is given, without exceeding the maximum temperature.

Control and test procedures according to DIN IEC 60512.

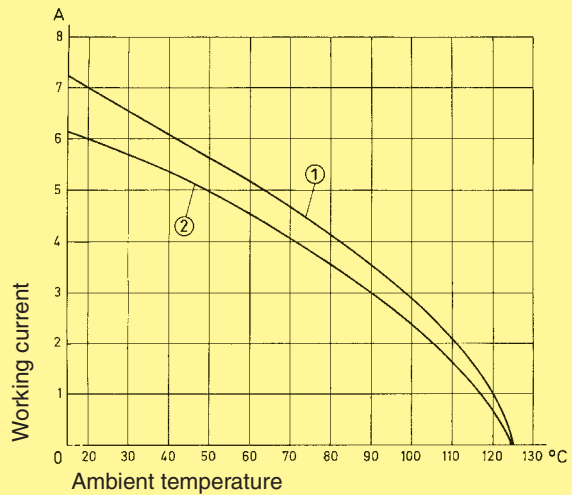

Example: 25 way connector

- ① Turned contacts
- ② Stamped contacts

### Contact arrangement View from termination side

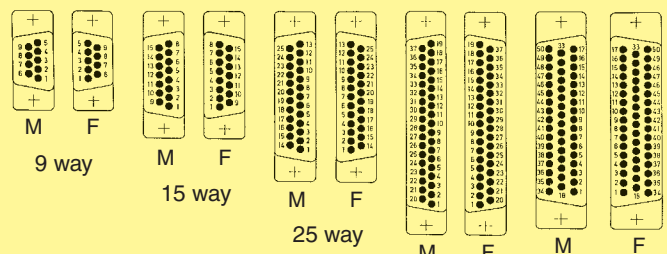

M = Male connector  
F = Female connector

### Mating conditions as per DIN 41 652

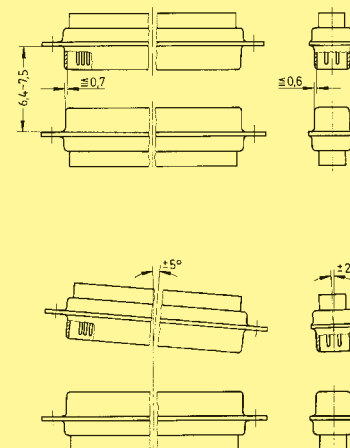

D-Sub

<sup>1)</sup> Performance level 3, 50 mating cycles, no gas test  
Performance level 2 as per CECC 75 301-802, 250 mating cycles, 4 days 4 mixed gas test – IEC 60512  
Performance level 1 as per CECC 75 301-802, 500 mating cycles, 10 days 4 mixed gas test – IEC 60512



Number of contacts

# 9–50

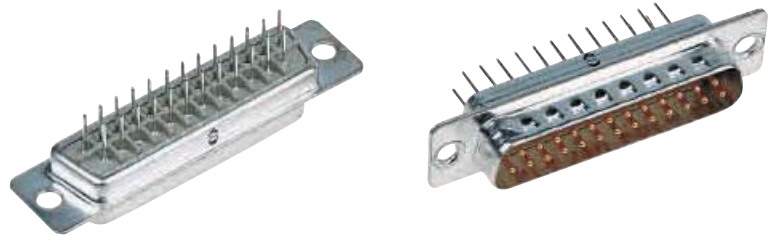

Turned solder pins, straight

Identification	No. of contacts	Part No.															
<b>Performance levels</b> Explanations see page 05.04 Other performance levels on request		<table border="1"> <tr> <th>Performance level 3</th> <th>Performance level 2</th> </tr> </table>	Performance level 3	Performance level 2													
Performance level 3	Performance level 2																
<b>Male connector</b> metal shell with dimples	<table border="1"> <tr><td>9</td><td>09 67 009 5654</td><td>09 67 009 5655</td></tr> <tr><td>15</td><td>09 67 015 5654</td><td>09 67 015 5655</td></tr> <tr><td>25</td><td>09 67 025 5654</td><td>09 67 025 5655</td></tr> <tr><td>37</td><td>09 67 037 5654</td><td>09 67 037 5655</td></tr> <tr><td>50</td><td>09 67 050 5654<sup>1)</sup></td><td>09 67 050 5655<sup>1)</sup></td></tr> </table>	9	09 67 009 5654	09 67 009 5655	15	09 67 015 5654	09 67 015 5655	25	09 67 025 5654	09 67 025 5655	37	09 67 037 5654	09 67 037 5655	50	09 67 050 5654 <sup>1)</sup>	09 67 050 5655 <sup>1)</sup>	
9	09 67 009 5654	09 67 009 5655															
15	09 67 015 5654	09 67 015 5655															
25	09 67 025 5654	09 67 025 5655															
37	09 67 037 5654	09 67 037 5655															
50	09 67 050 5654 <sup>1)</sup>	09 67 050 5655 <sup>1)</sup>															
<b>Female connector</b> metal shell	<table border="1"> <tr><td>9</td><td>09 67 009 4754</td><td>09 67 009 4755</td></tr> <tr><td>15</td><td>09 67 015 4754</td><td>09 67 015 4755</td></tr> <tr><td>25</td><td>09 67 025 4754</td><td>09 67 025 4755</td></tr> <tr><td>37</td><td>09 67 037 4754</td><td>09 67 037 4755</td></tr> <tr><td>50</td><td>09 67 050 4754<sup>1)</sup></td><td>09 67 050 4755<sup>1)</sup></td></tr> </table>	9	09 67 009 4754	09 67 009 4755	15	09 67 015 4754	09 67 015 4755	25	09 67 025 4754	09 67 025 4755	37	09 67 037 4754	09 67 037 4755	50	09 67 050 4754 <sup>1)</sup>	09 67 050 4755 <sup>1)</sup>	
9	09 67 009 4754	09 67 009 4755															
15	09 67 015 4754	09 67 015 4755															
25	09 67 025 4754	09 67 025 4755															
37	09 67 037 4754	09 67 037 4755															
50	09 67 050 4754 <sup>1)</sup>	09 67 050 4755 <sup>1)</sup>															

Male connector

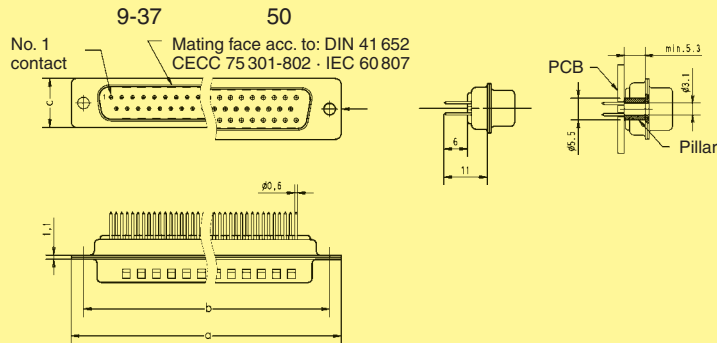

Female connector

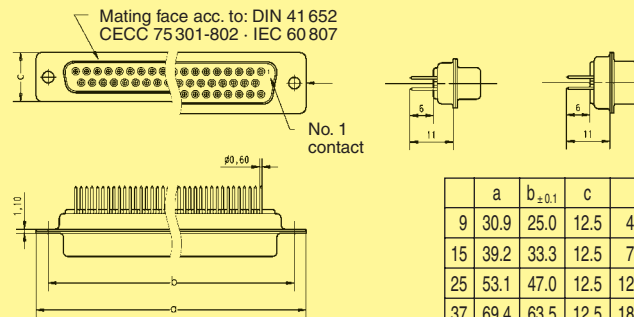

	a	b <sub>=0.1</sub>	c	g	h
9	30.9	25.0	12.5	4 x 2.74 = 10.96	3 x 2.74 = 8.22
15	39.2	33.3	12.5	7 x 2.74 = 19.18	6 x 2.74 = 16.44
25	53.1	47.0	12.5	12 x 2.76 = 33.12	11 x 2.76 = 30.36
37	69.4	63.5	12.5	18 x 2.76 = 49.68	17 x 2.76 = 46.92
50	67.0	61.1	15.4	16 x 2.76 = 44.16	15 x 2.76 = 41.40

Board drillings

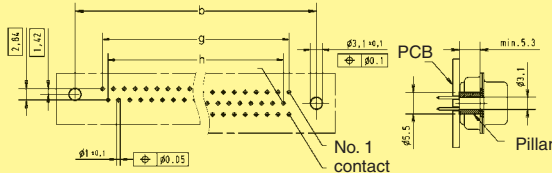

Dimensions in mm

<sup>1)</sup> Not normally kept in stock

Mating conditions see page 05.04

Number of contacts

# 9-50



Turned solder pins, straight without grounding-pins

Identification	No. of contacts	Part No.	
<b>Performance levels</b> Explanations see page 05.04 Other performance levels on request		Performance level <b>3</b>	Performance level <b>2</b>
<b>Male connector</b> metal shell with dimples  <div style="color: red; font-weight: bold; font-size: 1.2em;">                         available on request                     </div>	9 15 25 37 50	09 66 121 770 . 09 66 221 770 . 09 66 321 770 . 09 66 421 770 . 09 66 521 770 .	09 66 121 670 . 09 66 221 670 . 09 66 321 670 . 09 66 421 670 . 09 66 521 670 .
Please insert digit for flange thread or fitted female screw locks	M3 ▶ <b>1</b> 4-40 UNC ▶ <b>2</b> fitted screw locks 4-40 UNC ▶ <b>3</b>		

D-Sub

Male connector

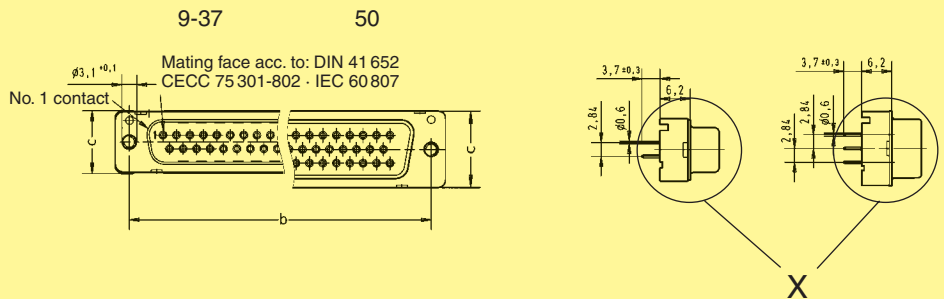

9-37      50

Mating face acc. to: DIN 41 652  
CECC 75 301-802 · IEC 60 807

	a	b <sub>±0,1</sub>	c	g	h
9	30.9	25.0	12.9	4 x 2.74 = 10.96	3 x 2.74 = 8.22
15	39.2	33.3	12.9	7 x 2.74 = 19.18	6 x 2.74 = 16.44
25	53.1	47.0	12.9	12 x 2.76 = 33.12	11 x 2.76 = 30.36
37	69.4	63.5	12.9	18 x 2.76 = 49.68	17 x 2.76 = 46.92
50	67.0	61.1	15.7	16 x 2.76 = 44.16	15 x 2.76 = 41.40

Board drillings

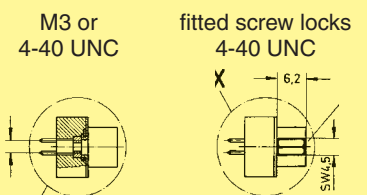
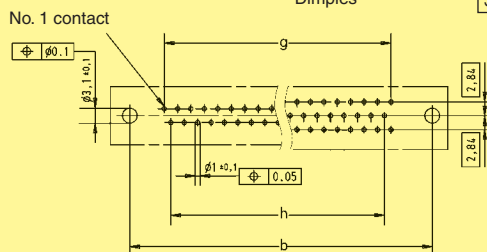

Dimensions in mm

Mating conditions see page 05.04



Number of contacts

**9-37**



Stamped solder pins, straight with/without grounding board locks

Identification	No. of contacts	Part No.	
<b>Performance levels</b> Explanations see page 05.04 Other performance levels on request		Performance level 3	Performance level 2
<b>Male connector</b> metal shell with dimples			
Without grounding board locks	9	09 65 121 770 .	09 65 121 670 .
	15	09 65 221 770 .	09 65 221 670 .
	25	09 65 321 770 .	09 65 321 670 .
	37	09 65 421 770 .	09 65 421 670 .
With grounding board locks	9	09 65 161 771 .	09 65 161 671 .
	15	09 65 261 771 .	09 65 261 671 .
	25	09 65 361 771 .	09 65 361 671 .
	37	09 65 461 771 .	09 65 461 671 .
<b>Female connector</b> metal shell			
Without grounding board locks	9	09 66 111 750 .	09 66 111 650 .
	15	09 66 211 750 .	09 66 211 650 .
	25	09 66 311 750 .	09 66 311 650 .
	37	09 66 411 750 .	09 66 411 650 .
	50	09 66 511 750 .	09 66 511 650 .
With grounding board locks	9	09 66 151 751 .	09 66 151 651 .
	15	09 66 251 751 .	09 66 251 651 .
	25	09 66 351 751 .	09 66 351 651 .
	37	09 66 451 751 .	09 66 451 651 .
Please insert digit for flange thread or fitted female screw locks			
M3 ▶	1		
4-40 UNC ▶	2		
fitted screw locks 4-40 UNC ▶	3 <sup>1)</sup>		

D-Sub

<sup>1)</sup> Fitted screw locks 4-40 UNC not normally kept in stock for performance level 3  
 Connector dimensions see page 05.09. Mating conditions see page 05.04.

Number of contacts

**9-37**

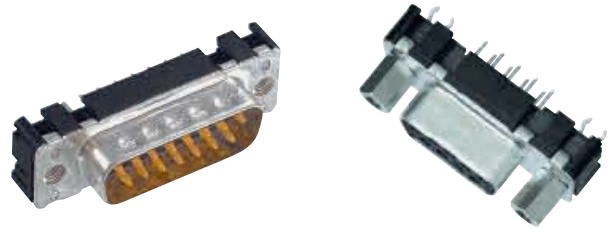

Stamped solder pins, straight with/without grounding board locks

Identification

Drawing

Dimensions in mm

**Male connector**  
9 – 37 contacts

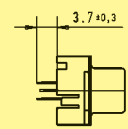
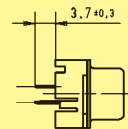
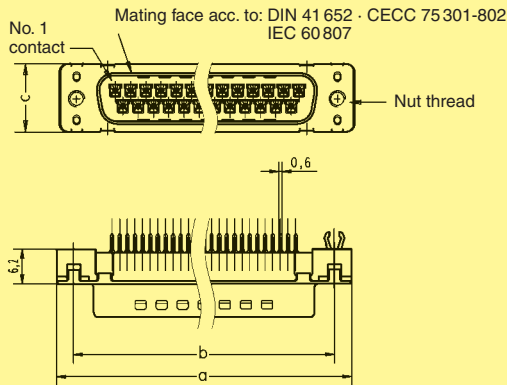

**Female connector**  
9 – 37 contacts

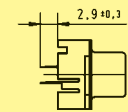
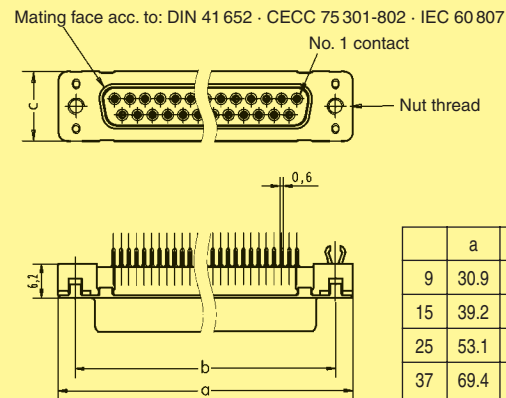

	a	b <sub>±0.1</sub>	c	g	h
9	30.9	25.0	12.5	4 x [2.74] = [10.96]	3 x [2.74] = [8.22]
15	39.2	33.3	12.5	7 x [2.74] = [19.18]	6 x [2.74] = [16.44]
25	53.1	47.0	12.5	12 x [2.76] = [33.12]	11 x [2.76] = [30.36]
37	69.4	63.5	12.5	18 x [2.76] = [49.68]	17 x [2.76] = [46.92]

**Board drillings**  
9 – 37 contacts

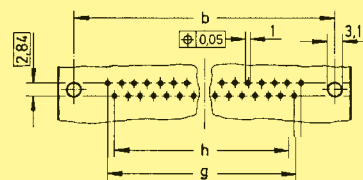

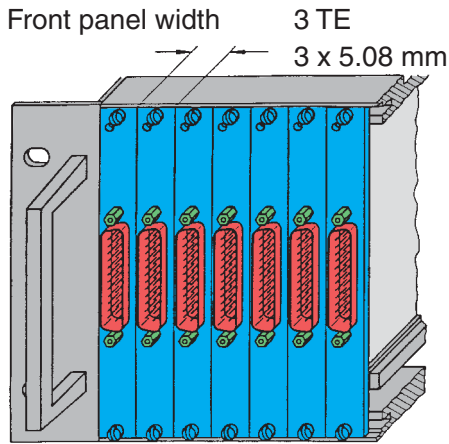

Low-Profile Versions  
pages 05.18 – 05.21

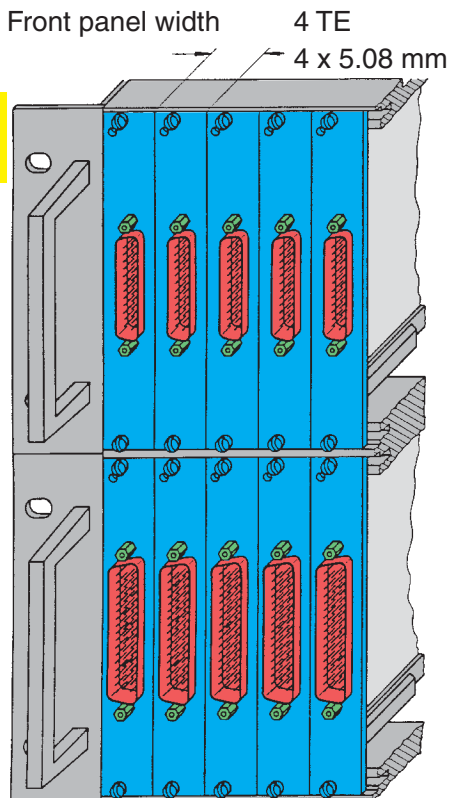
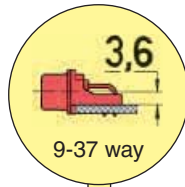

Standard Versions  
pages 05.12 – 05.17

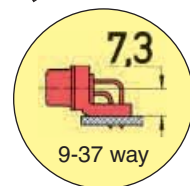

U.S. Footprint Versions  
pages 05.22 – 05.23

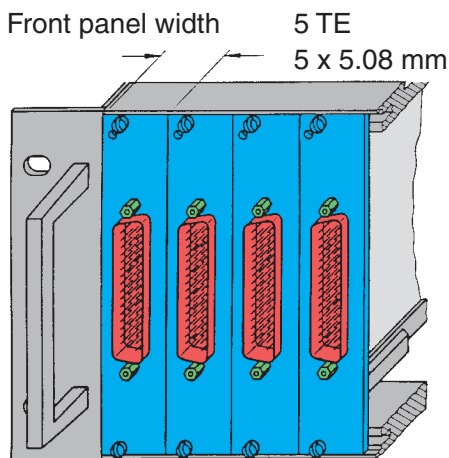
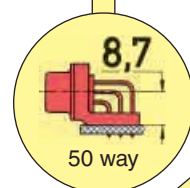
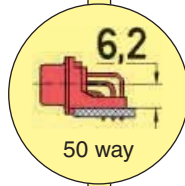
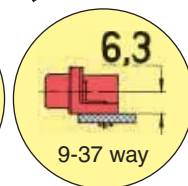

Metal shell mating face

Fixed contacts

Integrated mounting bracket

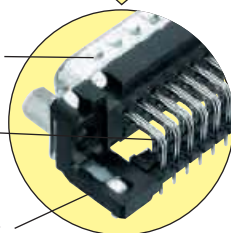

Advantages

- All-round protective metal shell
- Polarisation
- Contact protection
- Plated shell
- Male connector with dimples

Plated terminations for increased solderability

Grounding contact riveted to metal shell

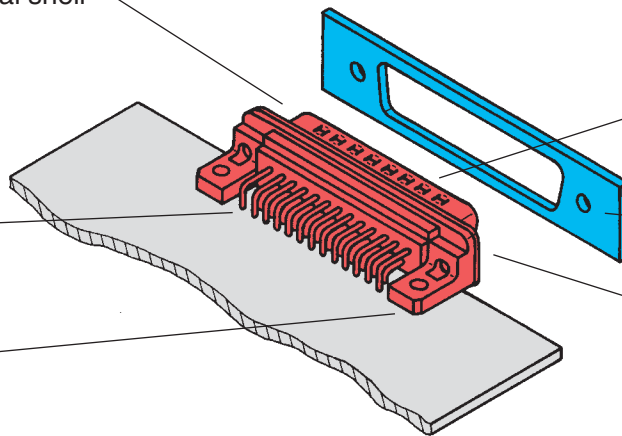

Contact surface finish to different performance levels

Panel

Different metal threads possible in flange area

- M3
- 4-40 UNC
- fitted female screw locks 4-40 UNC
- max. torque ≤ 0.8 Nm

Integrated plastic mounting bracket

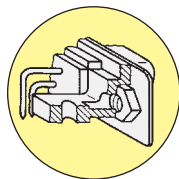

Mounting bracket

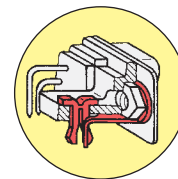

Mounting bracket with snap-in-clips and grounding pin

D-Sub

Mounting height

Low-Profile Versions

The reduced mounting height of these connectors allow them to be used on the same PCB as DIN 41 612

types with no loss of packaging density when card frames to DIN 41 494 are used.

9-37 way connectors with 3.6 mm mounting height can be fitted to front panels of 3 TE (15.24 mm) width.

50 way connectors with 6.2 mm mounting height can be fitted to front panels of 4 TE (20.32 mm) width.

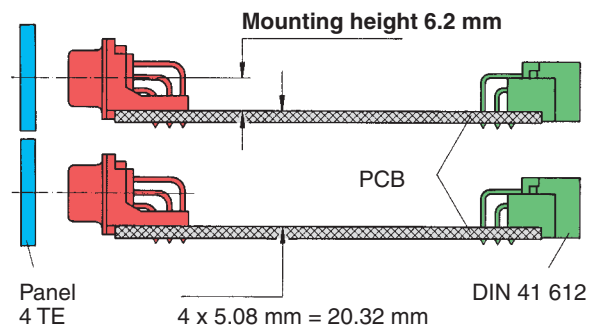
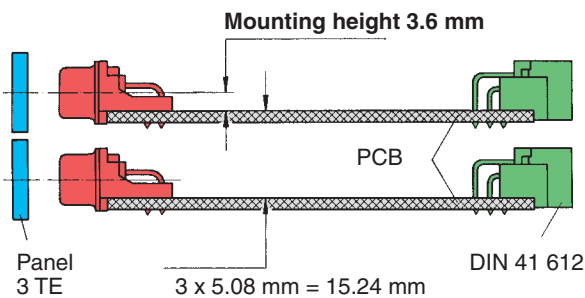

Standard Versions

Original Versions

US Footprint

9-37 way connectors with 7.3 mm mounting height can be fitted to front panels of 4 TE (20.32 mm) width.

50 way connectors with 8.7 mm mounting height can be fitted to front panels of 5 TE (25.4 mm) width.

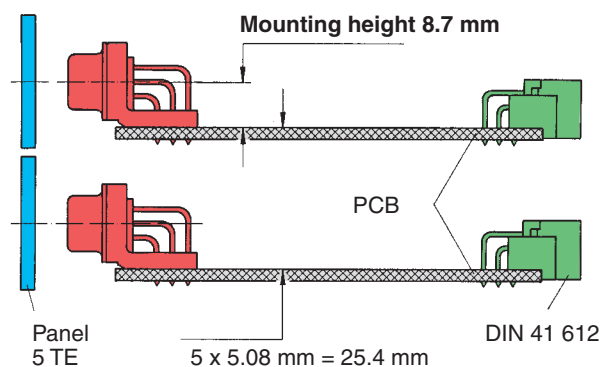
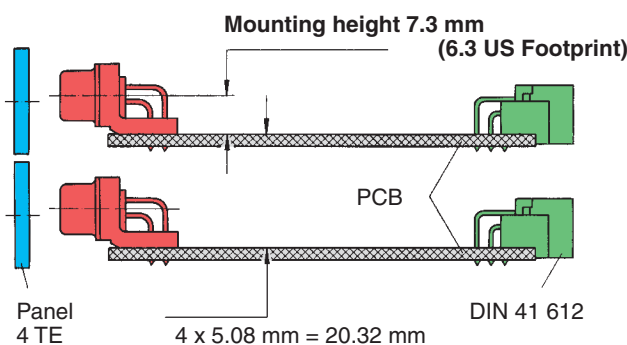

Number of contacts

Mounting height

9-37  
50

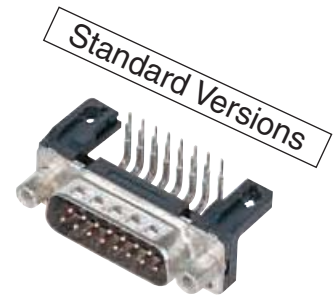
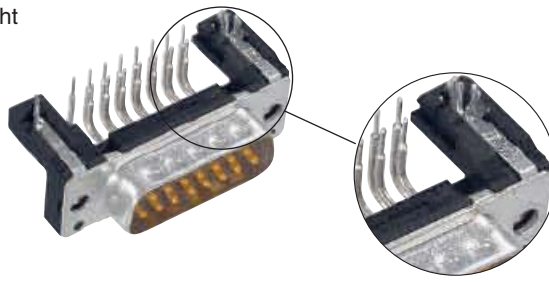
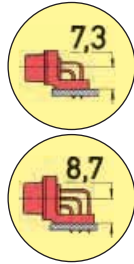

Turned solder pins, angled with/without snap-in-clips and grounding board locks

Identification	No. of contacts	Part No.	
<b>Performance levels</b> Explanations see page 05.04 Other performance levels on request		Performance level 3	Performance level 2
<b>Male connector</b> metal shell with dimples		2.84 mm pitch	2.84 mm pitch
With snap-in clips and grounding board locks	9 15 25 37 50	09 66 163 781 09 66 263 781 09 66 363 781 09 66 463 781 09 66 563 781	09 66 163 681 09 66 263 681 09 66 363 681 09 66 463 681 09 66 563 681
		2.54 mm pitch	2.54 mm pitch
	9 15 25 37 50	09 66 162 781 09 66 262 781 09 66 362 781 09 66 462 781 09 66 562 781	09 66 162 681 09 66 262 681 09 66 362 681 09 66 462 681 09 66 562 681
Without snap-in clips and grounding board locks	9 15 25 37 50	09 66 123 780 09 66 223 780 09 66 323 780 09 66 423 780 09 66 523 780	09 66 123 680 09 66 223 680 09 66 323 680 09 66 423 680 09 66 523 680
		2.54 mm pitch	2.54 mm pitch
	9 15 25 37 50	09 66 122 780 09 66 222 780 09 66 322 780 09 66 422 780 09 66 522 780	09 66 122 680 09 66 222 680 09 66 322 680 09 66 422 680 09 66 522 680
Please insert digit for flange thread or fitted female screw locks			
M3 ▶ 1 4-40 UNC ▶ 2 fitted screw locks 4-40 UNC ▶ 3			

D-Sub

Number of contacts

Mounting height

9-37  
50

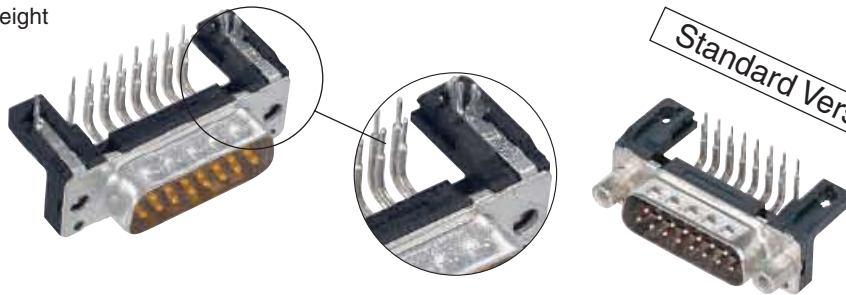
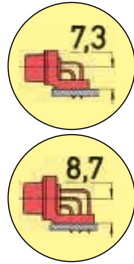

Standard Versions

Turned solder pins, angled with/without snap-in-clips and grounding board locks

Identification

Drawing

Dimensions in mm

Male connector

With snap-in clips and grounding board locks

Without snap-in clips and grounding board locks

Board drillings

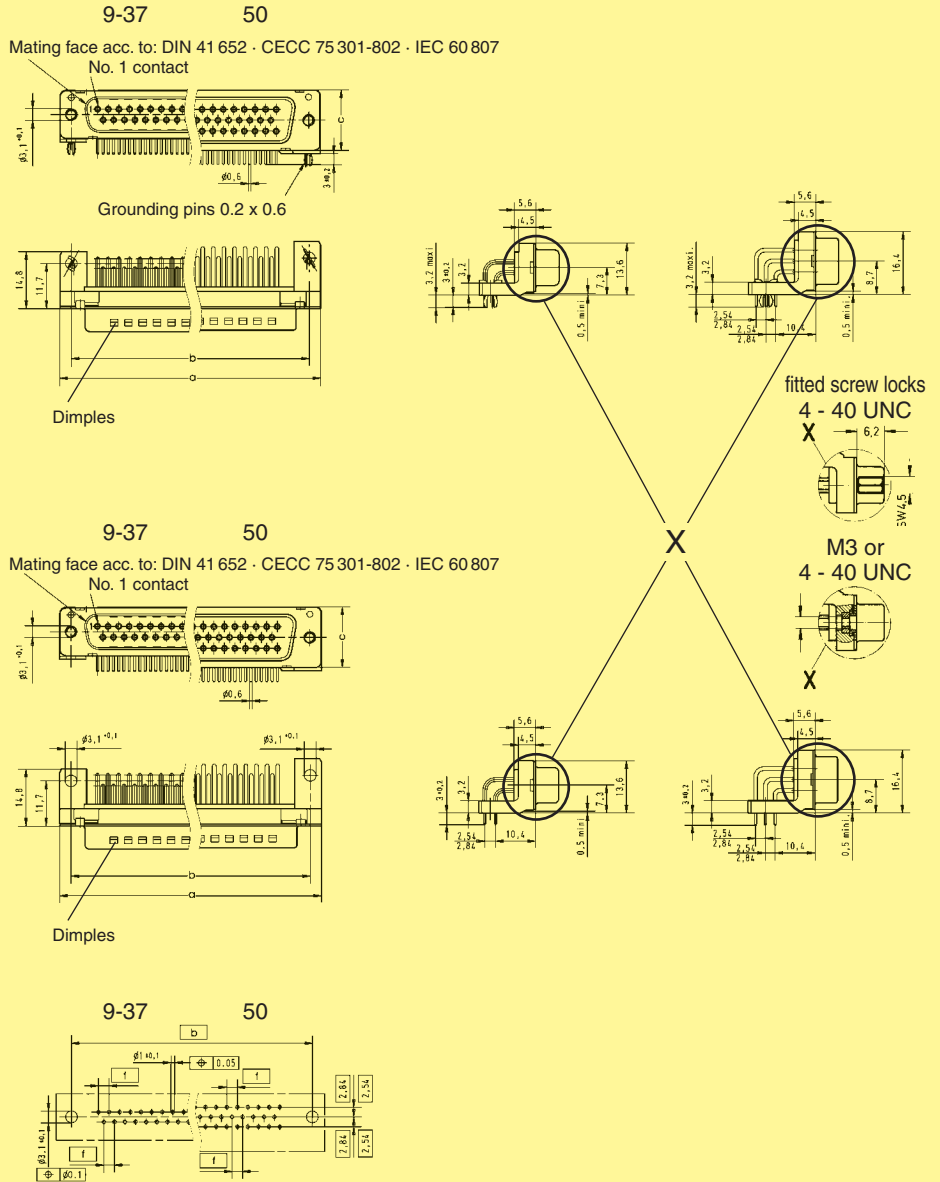

	a	b±0.1	c	f
9	30.90	25.00	12.90	2.74
15	39.20	33.30	12.90	2.74
25	53.10	47.00	12.90	2.76
37	69.40	63.50	12.90	2.76
50	67.00	61.10	15.70	2.76

D-Sub

Number of contacts

Mounting height

9-37  
50

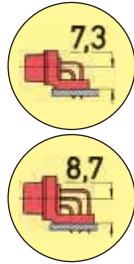

Standard Versions

Stamped solder pins, angled with grounding board locks

Identification	No. of contacts	Part No.		
<b>Performance levels</b> Explanations see page 05.04 Other performance levels on request		Performance level 3	Performance level 2	
<b>Male connector</b> metal shell with dimples	2.84 mm pitch  9 15 25 37	09 65 163 781 . 1)	09 65 163 681 . 1)	
		09 65 263 781 . 1)	09 65 263 681 . 1)	
		09 65 363 781 . 1)	09 65 363 681 . 1)	
		09 65 463 781 . 1)	09 65 463 681 . 1)	
		2.54 mm pitch  9 15 25 37	09 65 162 781 .	09 65 162 681 .
		09 65 262 781 .	09 65 262 681 .	
		09 65 362 781 .	09 65 362 681 .	
		09 65 462 781 .	09 65 462 681 .	
	<b>Female connector</b> metal shell	2.84 mm pitch  9 15 25 37 50	09 66 153 761 . 1)	09 66 153 661 . 1)
			09 66 253 761 . 1)	09 66 253 661 . 1)
			09 66 353 761 . 1)	09 66 353 661 . 1)
			09 66 453 761 . 1)	09 66 453 661 . 1)
			09 66 553 761 . 1)	09 66 553 661 . 1)
			2.54 mm pitch  9 15 25 37 50	09 66 152 761 .
09 66 252 761 .			09 66 252 661 .	
09 66 352 761 .			09 66 352 661 .	
09 66 452 761 .		09 66 452 661 .		
09 66 552 761 . 1)		09 66 552 661 . 1)		
Please insert digit for flange thread or fitted female screw locks				
Ø 3.1 mm hole ▶ 0 <sup>1)</sup>				
M3 ▶ 1				
4-40 UNC ▶ 2				
fitted screw locks 4-40 UNC ▶ 3				

D-Sub

<sup>1)</sup> Not normally kept in stock



Number of contacts

Mounting height

9-37  
50

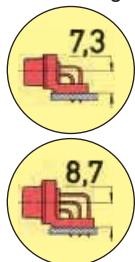

Stamped solder pins, angled with grounding board locks

Identification

Drawing

Dimensions in mm

Male connector

Mating face acc. to: DIN 41 652 · CECC 75 301-802  
IEC 60 807

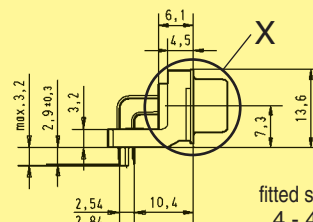
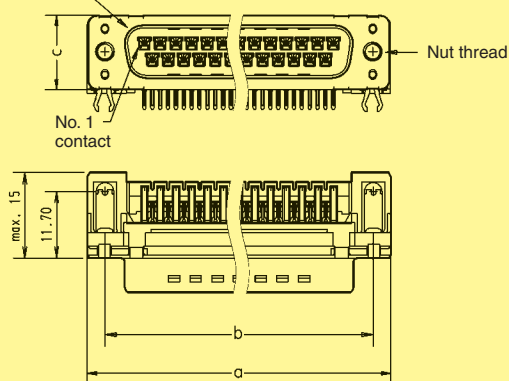

fitted screw locks  
4 - 40 UNC

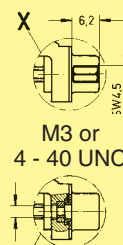

Female connector

9-37 50

Mating face acc. to: DIN 41 652 · CECC 75 301-802  
IEC 60 807

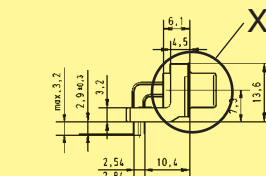
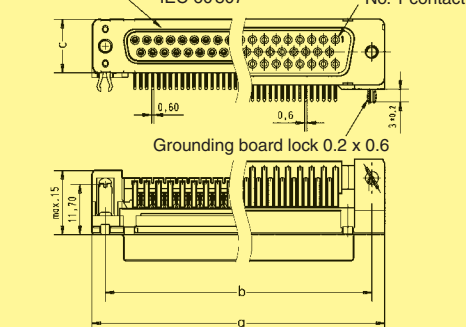

9-37

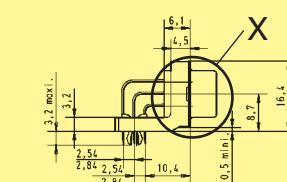

50

Board drillings

9-37 50

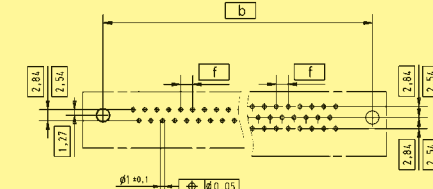

	a	b±0.1	c	f
9	30.90	25.00	12.50	2.74
15	39.20	33.30	12.50	2.74
25	53.10	47.00	12.50	2.76
37	69.40	63.50	12.50	2.76
50	67.00	61.10	15.40	2.76



Number of contacts

Mounting height

9-37  
50

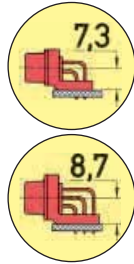

Standard Versions

Stamped solder pins, angled without grounding board locks

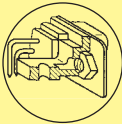
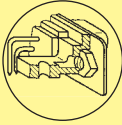
Identification	No. of contacts	Part No.		
<b>Performance levels</b> Explanations see page 05.04 Other performance levels on request		Performance level 3	Performance level 2	
<b>Male connector</b> metal shell with dimples  	9 15 25 37	2.84 mm pitch	2.84 mm pitch	
		09 65 123 780 .	09 65 123 680 .	
		09 65 223 780 .	09 65 223 680 .	
		09 65 323 780 .	09 65 323 680 .	
		09 65 423 780 .	09 65 423 680 .	
		2.54 mm pitch	2.54 mm pitch	
		09 65 122 780 .	09 65 122 680 .	
		09 65 222 780 .	09 65 222 680 .	
	09 65 322 780 .	09 65 322 680 .		
	09 65 422 780 .	09 65 422 680 .		
	<b>Female connector</b> metal shell  	9 15 25 37 50	2.84 mm pitch	2.84 mm pitch
			09 66 113 760 . <sup>1)</sup>	09 66 113 660 . <sup>1)</sup>
			09 66 213 760 . <sup>1)</sup>	09 66 213 660 . <sup>1)</sup>
			09 66 313 760 . <sup>1)</sup>	09 66 313 660 . <sup>1)</sup>
09 66 413 760 . <sup>1)</sup>			09 66 413 660 . <sup>1)</sup>	
09 66 513 760 . <sup>1)</sup>		09 66 513 660 . <sup>1)</sup>		
2.54 mm pitch		2.54 mm pitch		
09 66 112 760 .		09 66 112 660 .		
09 66 212 760 .		09 66 212 660 .		
09 66 312 760 .		09 66 312 660 .		
09 66 412 760 .	09 66 412 660 .			
09 66 512 760 . <sup>1)</sup>	09 66 512 660 . <sup>1)</sup>			
Please insert digit for flange thread or fitted female screw locks				
Ø 3.1 mm hole ▶ 0 <sup>1)</sup> M3 ▶ 1 4-40 UNC ▶ 2 fitted screw locks 4-40 UNC ▶ 3				

D-Sub

<sup>1)</sup> Not normally kept in stock

Number of contacts

Mounting height

9-37  
50

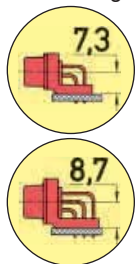

Standard Versions

Stamped solder pins, angled without grounding board locks

Identification

Drawing

Dimensions in mm

Male connector

Mating face acc. to: DIN 41 652 · CECC 75 301-802 · IEC 60 807

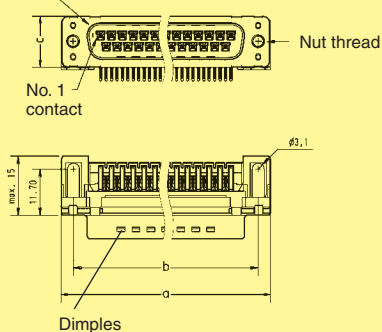

fitted screw locks  
4 - 40 UNC

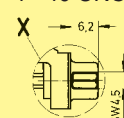

M3 or  
4 - 40 UNC

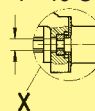

Female connector

Mating face acc. to: DIN 41 652 · CECC 75 301-802 · IEC 60 807

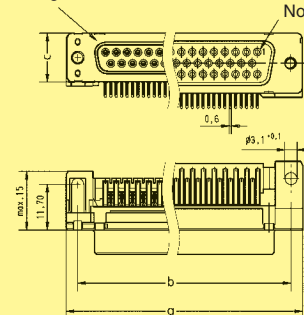

Board drillings

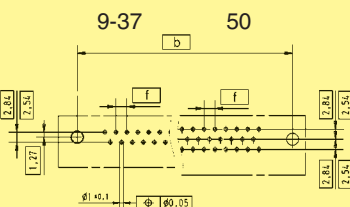

	a	b±0.1	c	f
9	30.90	25.00	12.50	2.74
15	39.20	33.30	12.50	2.74
25	53.10	47.00	12.50	2.76
37	69.40	63.50	12.50	2.76
50	67.00	61.10	15.40	2.76

D-Sub

Number of contacts

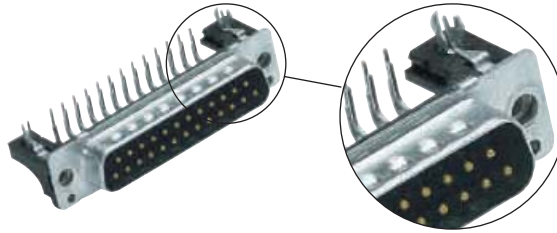
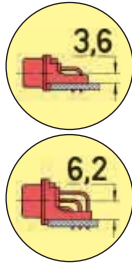

Mounting height

9-37  
50

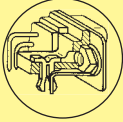

Low-Profile Versions

Turned solder pins, angled with snap-in-clips and grounding board locks

Identification	No. of contacts	Part No.	
<b>Performance levels</b> Explanations see page 05.04 Other performance levels on request		Performance level 3	Performance level 2
<b>Male connector</b> metal shell with dimples  		2.54 mm pitch	2.54 mm pitch
	9	09 66 162 781	09 66 162 681
	15	09 66 262 781	09 66 262 681
	25	09 66 362 781	09 66 362 681
	37	09 66 462 781	09 66 462 681
	50	09 66 562 781	09 66 562 681
Please insert digit for flange thread or fitted female screw locks			
M3 ▶ 5 4-40 UNC ▶ 6 fitted screw locks 4-40 UNC ▶ 7			

D-Sub

Number of contacts

Mounting height

9-37  
50

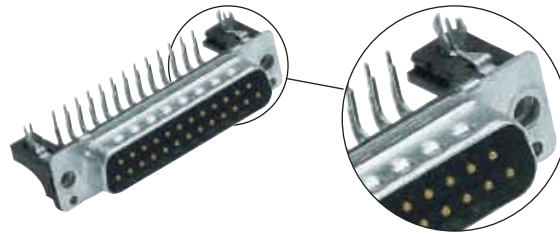
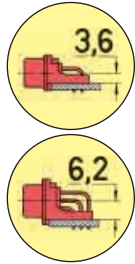

Low-Profile Versions

Turned solder pins, angled with snap-in-clips and grounding board locks

Identification

Drawing

Dimensions in mm

Male connector

9-37 50  
Mating face acc. to: DIN 41 652 · CECC 75 301-802 · IEC 60 807  
No. 1 contact

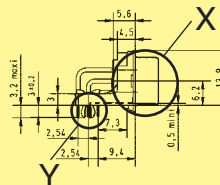
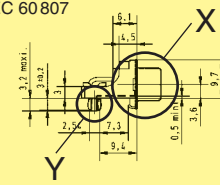
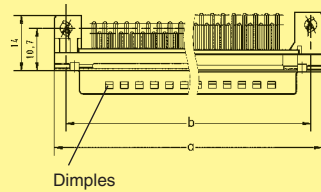
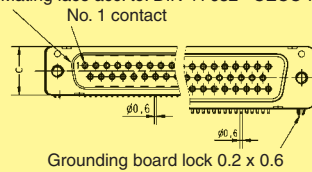

fitted screw locks  
4 - 40 UNC

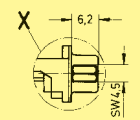

M3 or  
4 - 40 UNC

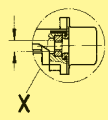

Board drillings

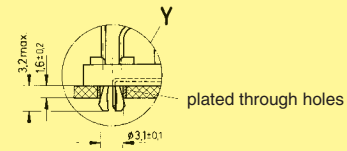
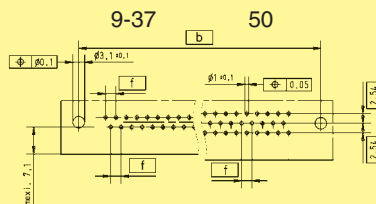

	a	b $\pm 0.1$	c	f
9	30.90	25.00	12.50	2.74
15	39.20	33.30	12.50	2.74
25	53.10	47.00	12.50	2.76
37	69.40	63.50	12.50	2.76
50	67.00	61.10	15.70	2.76

D-Sub

Number of contacts

Mounting height

9-37  
50

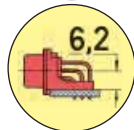
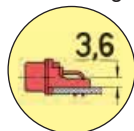

Low-Profile Versions

Stamped solder pins, angled with grounding board locks

Identification	No. of contacts	Part No.			
Performance levels Explanations see page 05.04 Other contact surfaces on request		Performance level 3		Performance level 2	
		3		2	
<b>Male connector</b> metal shell with dimples	9	09 65 162 781 .		09 65 162 681 .	
	15	09 65 262 781 .		09 65 262 681 .	
	25	09 65 362 781 .		09 65 362 681 .	
	37	09 65 462 781 .		09 65 462 681 .	
<b>Female connector</b> metal shell	9	09 66 152 761 .		09 66 152 661 .	
	15	09 66 252 761 .		09 66 252 661 .	
	25	09 66 352 761 .		09 66 352 661 .	
	37	09 66 452 761 .		09 66 452 661 .	
	50	09 66 552 761 . <sup>1)</sup>		09 66 552 661 . <sup>1)</sup>	
Please insert digit for flange thread or fitted female screw locks	M3 ▶		5		
	4-40 UNC ▶		6		
	fitted screw locks 4-40 UNC ▶		7		

D-Sub

<sup>1)</sup> Not normally kept in stock

Number of contacts

Mounting height

9-37  
50

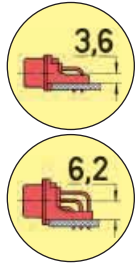

Low-Profile Versions

Stamped solder pins, angled with grounding board locks

Identification

Drawing

Dimensions in mm

Male connector

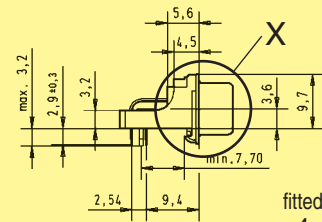
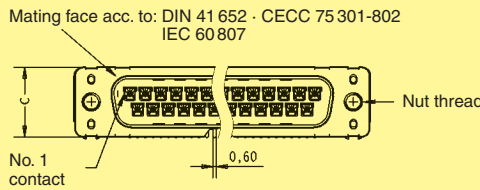

fitted screw locks  
4 - 40 UNC

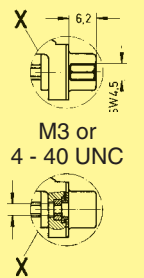

Female connector

9-37 50

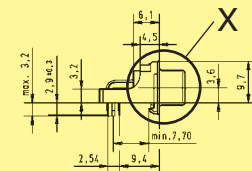
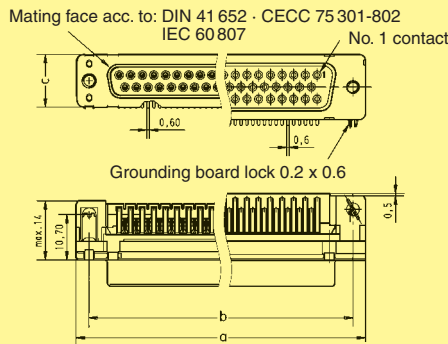

9-37

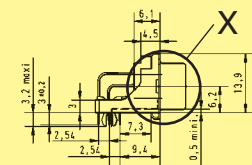

50

Board drillings

9-37 50

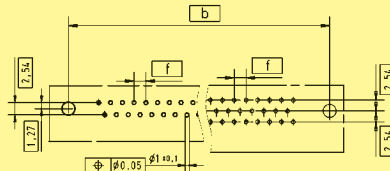

	a	b±0.1	c	f
9	30.90	25.00	12.50	2.74
15	39.20	33.30	12.50	2.74
25	53.10	47.00	12.50	2.76
37	69.40	63.50	12.50	2.76
50	67.00	61.10	15.40	2.76

D-Sub

Number of contacts

**9-37**

Mounting height

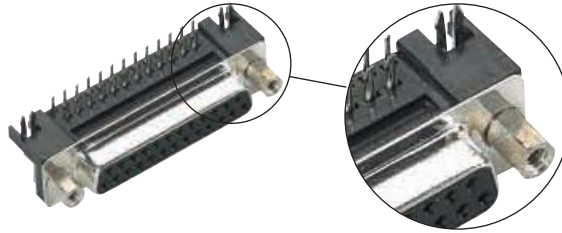
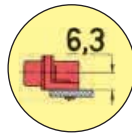

U.S. Footprint

Stamped solder pins, angled with snap-in-clips and grounding board locks

Identification	No. of contacts	Performance level		Part No.	
<b>Performance levels</b> Explanations see page 05.04 Other performance levels on request		3		S4 <sup>1)</sup>	
<b>Male connector</b> metal shell with dimples		2.84 mm pitch		2.84 mm pitch	
	9	09 68 163 781	.	09 68 163 581	.
	15	09 68 263 781	.	09 68 263 581	.
	25	09 68 363 781	.	09 68 363 581	.
	37	09 68 463 781	.	09 68 463 581	.
<b>Female connector</b> metal shell		2.84 mm pitch		2.84 mm pitch	
	9	09 68 153 761	.	09 68 153 561	.
	15	09 68 253 761	.	09 68 253 561	.
	25	09 68 353 761	.	09 68 353 561	.
	37	09 68 453 761	.	09 68 453 561	.
Please insert digit for flange thread or fitted female screw locks					
M3 ▶ 1 <sup>2)</sup> 4-40 UNC ▶ 2 fitted screw locks 4-40 UNC ▶ 3					

D-Sub

<sup>1)</sup> S4: ≥ 0.76 µm Au (30 µinch)

<sup>2)</sup> Not normally kept in stock

Number of contacts

9-37

Mounting height

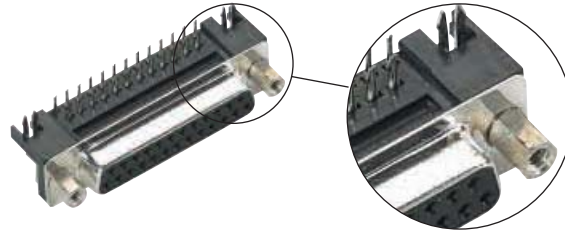
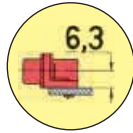

U.S. Footprint

Stamped solder pins, angled with snap-in-clips and grounding board locks

Identification

Drawing

Dimensions in mm

Male connector

Mating face acc. to: DIN 41 652 · CECC 75 301-802  
IEC 60 807

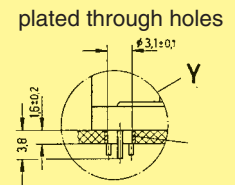
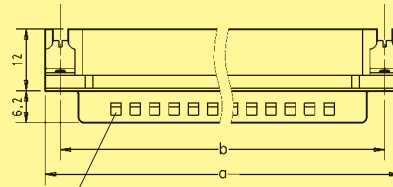
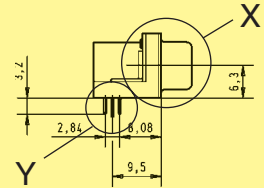
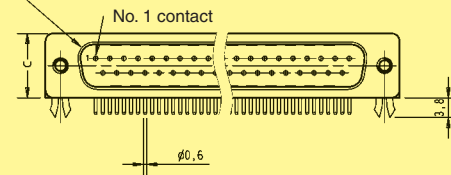

plated through holes

Female connector

Mating face acc. to: DIN 41 652 · CECC 75 301-802  
IEC 60 807

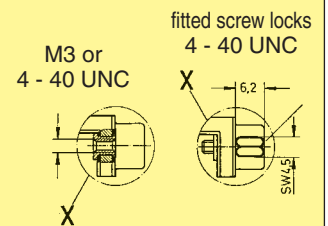
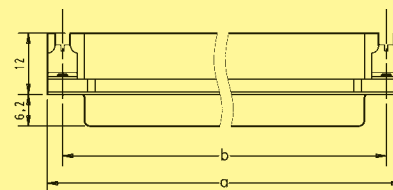
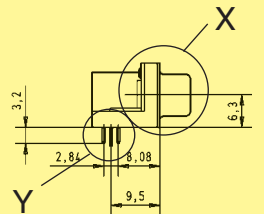
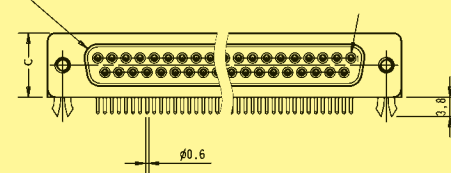

Board drillings

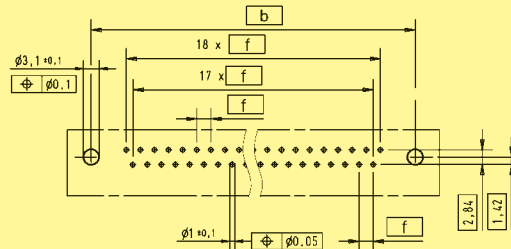

	a	b±0.1	c	f
9	30.90	25.00	12.55	2.77
15	39.20	33.30	12.55	2.77
25	53.10	47.00	12.55	2.77
37	69.40	63.50	12.55	2.77

D-Sub



Identification

Drawing

Dimensions in mm

**Standard Versions**

Mounting height 7.3 mm  
9-37 way  
for front panel  
4 units of width (TE)

Mounting height 8.7 mm  
50 way  
for front panel  
5 units of width (TE)

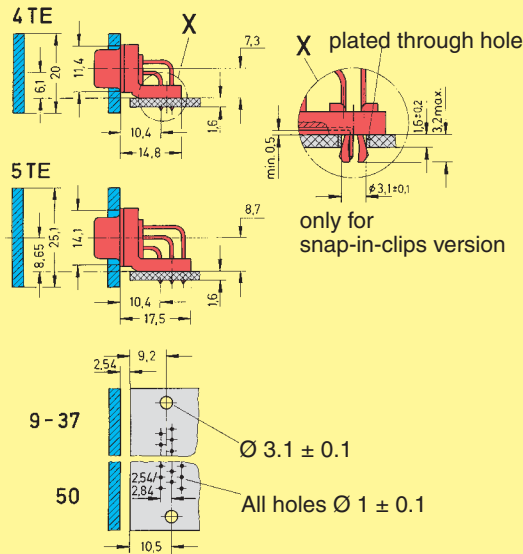

for connectors see pages 05.12 – 05.17

**Low-Profile Versions**

Mounting height 3.6 mm  
9-37 way  
for front panel  
3 units of width (TE)

Mounting height 6.2 mm  
50 way  
for front panel  
4 units of width (TE)

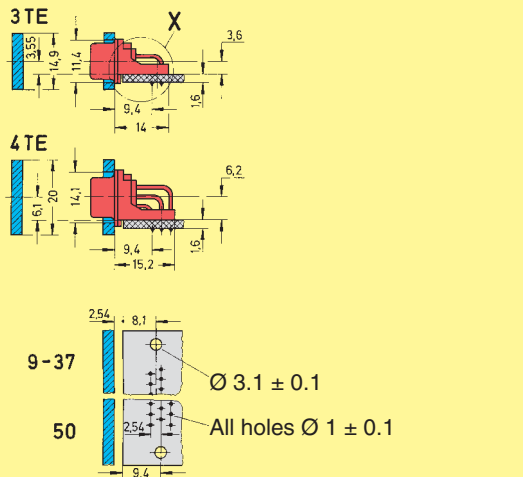

When used in a wave soldering process the mating face of the connector must be protected with adhesive tape.



for connectors see pages 05.18 – 05.21

**U.S. Footprint Versions**

Mounting height 6.3 mm  
9-37 way  
for front panel  
4 units of width (TE)

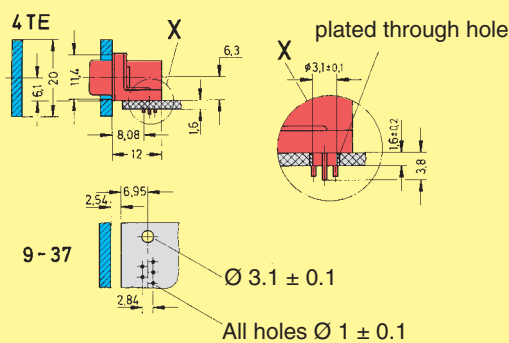

for connectors see pages 05.22 – 05.23

**Panel cut out for front/rear mount**

Values are taken from the CECC 75 301-802

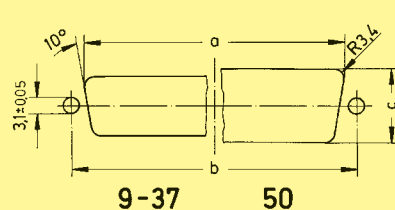

Front mount

Rear mount

	$a_{\pm 0.2}$	$b_{\pm 0.13}$	$c_{\pm 0.2}$		$a_{\pm 0.2}$	$b_{\pm 0.13}$	$c_{\pm 0.2}$
9	22.2	25.0	12.3	9	20.5	25.0	11.4
15	30.5	33.3	12.3	15	28.8	33.3	11.4
25	44.3	47.0	12.3	25	42.5	47.0	11.4
37	60.7	63.5	12.3	37	59.1	63.5	11.4
50	58.3	61.1	15.1	50	56.3	61.1	14.1

Number of contacts

# 9-50



Crimp terminal

Identification	No. of contacts	Part No.
<b>Male connector</b> Order contacts separately  metal shell with dimples	9	09 67 009 5601
	15	09 67 015 5601
	25	09 67 025 5601
	37	09 67 037 5601
	50	09 67 050 5601
<b>Female connector</b> Order contacts separately  metal shell	9	09 67 009 4701
	15	09 67 015 4701
	25	09 67 025 4701
	37	09 67 037 4701
	50	09 67 050 4701

Male connector

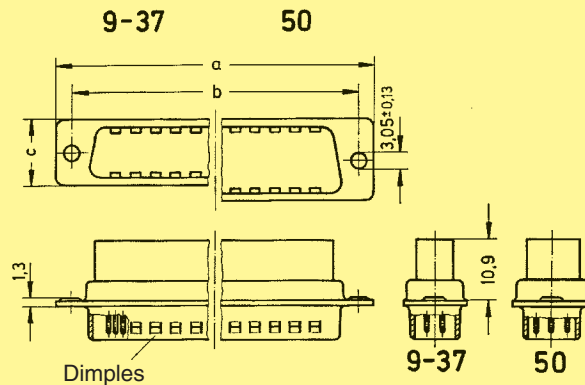

Female connector

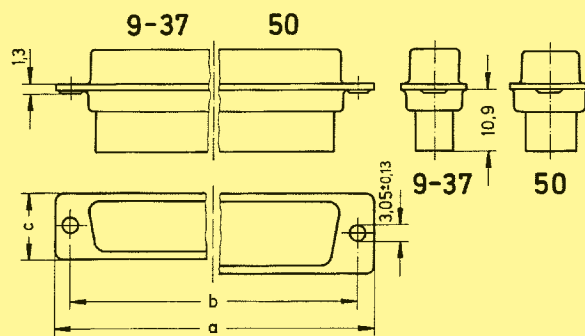

	a	b <sub>±0.1</sub>	c
9	30.9	25.0	12.5
15	39.2	33.3	12.5
25	53.1	47.0	12.5
37	69.4	63.5	12.5
50	67.0	61.1	15.4

Panel cut out for front/rear mount

Values are taken from the CECC 75 301-802

see page 05.24

Dimensions in mm



## Crimp contacts



Identification	Wire gauge (mm <sup>2</sup> )	Part No.	
		turned male contacts	turned female contacts
		Performance level 1*	Performance level 1*
Individual contacts	AWG 22-18 0.33-0.82	61 03 000 0112	61 03 000 0113
	AWG 22-20 0.33-0.52	61 03 000 0073	61 03 000 0074
	AWG 26-22 0.13-0.33	61 03 000 0094	61 03 000 0096
	AWG 28-24 0.09-0.25	61 03 000 0078	61 03 000 0080

D-Sub

### Male contacts

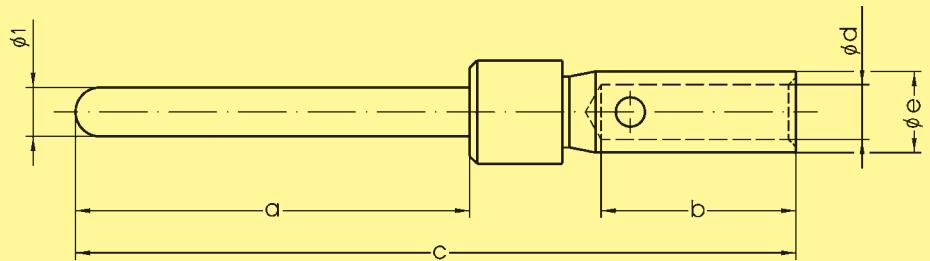

	a	b	c	d	e	f
AWG 22-18	8.23	4.2	14.0	1.35	1.75	13.6
AWG 22-20	8.10	4.0	14.8	1.12	1.66	14.4
AWG 26-22	8.10	4.0	14.8	0.90	1.66	14.4
AWG 28-24	8.10	4.0	14.8	0.64	1.66	14.4

### Female contacts

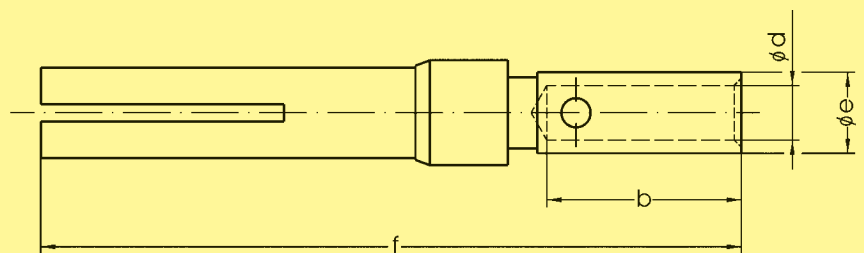

\* Performance level 1 as per CECC 75 301-802, 500 mating cycles, 10 days 4 mixed gas test – IEC 60512

Crimp contacts



Identification	Wire gauge (mm <sup>2</sup> )	Part No.		
<b>Performance levels</b> Explanations see page 05.04 Other performance levels on request		stamped male contacts		
		Performance level 3	Performance level 2	Performance level 1
<b>Individual contacts</b>	0.09-0.25 AWG 28-24	09 67 000 7177 <sup>1)</sup>	09 67 000 7178 <sup>1)</sup>	09 67 000 7176 <sup>1)</sup>
500 pieces/reel Unrolling left	stranded	09 67 000 7167	09 67 000 7168	09 67 000 7166
10 000 pieces/reel Unrolling left Unrolling left reversed Unrolling right reversed		09 67 000 7157 09 67 000 7147 09 67 000 7137	09 67 000 7158 09 67 000 7148 09 67 000 7138	09 67 000 7156 09 67 000 7146 09 67 000 7136
<b>Individual contacts</b>	0.25-0.56 AWG 24-20	09 67 000 8177 <sup>1)</sup>	09 67 000 8178 <sup>1)</sup>	09 67 000 8176 <sup>1)</sup>
500 pieces/reel Unrolling left	stranded	09 67 000 8167	09 67 000 8168	09 67 000 8166
10 000 pieces/reel Unrolling left Unrolling left reversed Unrolling right reversed		09 67 000 8157 09 67 000 8147 09 67 000 8137	09 67 000 8158 09 67 000 8148 09 67 000 8138	09 67 000 8156 09 67 000 8146 09 67 000 8136
<b>Unrolling direction</b>		<p>500 pieces/reel Unrolling left    10 000 pieces/reel Unrolling left    10 000 pieces/reel Unrolling left reversed    10 000 pieces/reel Unrolling right reversed</p> <p style="text-align: center;">for HARTING tools</p>		

D-Sub

<sup>1)</sup> Minimum order 500 pieces or multiples of 500  
 Insertion and removal tool see chapter 20  
 Contact dimensions see page 05.29

Crimp contacts

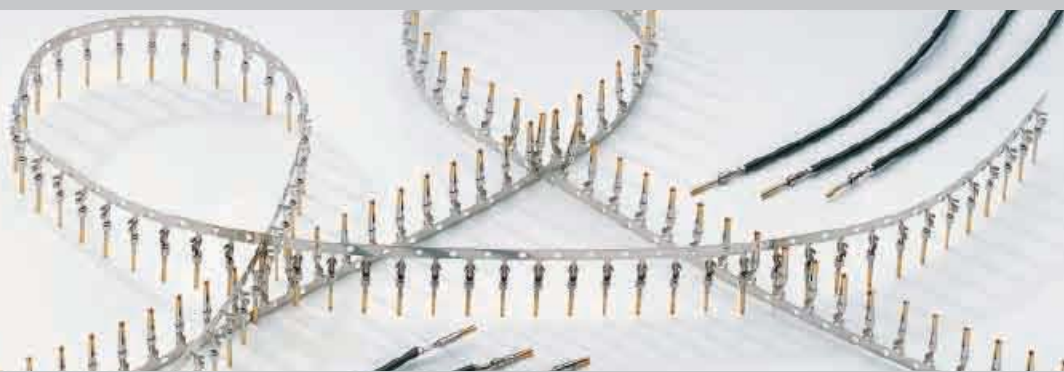

Identification

Drawing

Dimensions in mm

Male contacts

For bandoliered contacts only

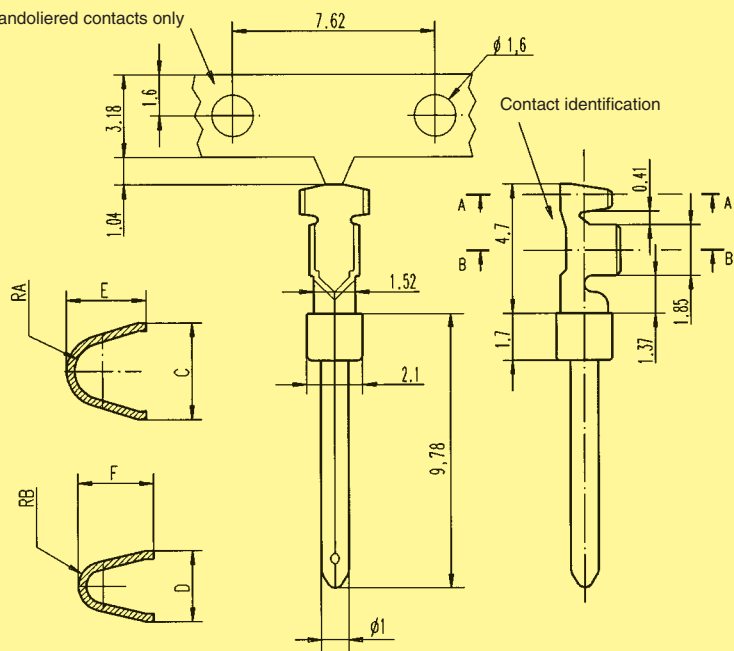

AWG	C	D	E	F	RA	RB	Contact identification
20-24	2.46	1.78	1.98	1.90	0.71	0.43	—
24-28	1.65	1.47	1.52	1.52	0.50	0.33	===

D-Sub

Crimp contacts



Identification	Wire gauge (mm <sup>2</sup> )	Part No.		
<b>Performance levels</b> Explanations see page 05.04 Other performance levels on request		stamped female contacts		
		Performance level 3	Performance level 2	Performance level 1
<b>Individual contacts</b>	0.09-0.25 AWG 28-24	09 67 000 7277 <sup>1)</sup>	09 67 000 7278 <sup>1)</sup>	09 67 000 7276 <sup>1)</sup>
500 pieces/reel Unrolling left	stranded	09 67 000 7267	09 67 000 7268	09 67 000 7266
10 000 pieces/reel Unrolling left Unrolling left reversed Unrolling right reversed		09 67 000 7257 09 67 000 7247 09 67 000 7237	09 67 000 7258 09 67 000 7248 09 67 000 7238	09 67 000 7256 09 67 000 7246 09 67 000 7236
<b>Individual contacts</b>	0.25-0.56 AWG 24-20	09 67 000 8277 <sup>1)</sup>	09 67 000 8278 <sup>1)</sup>	09 67 000 8276 <sup>1)</sup>
500 pieces/reel Unrolling left	stranded	09 67 000 8267	09 67 000 8268	09 67 000 8266
10 000 pieces/reel Unrolling left Unrolling left reversed Unrolling right reversed		09 67 000 8257 09 67 000 8247 09 67 000 8237	09 67 000 8258 09 67 000 8248 09 67 000 8238	09 67 000 8256 09 67 000 8246 09 67 000 8236
<b>Unrolling direction</b>		<p>500 pieces/reel Unrolling left    10 000 pieces/reel Unrolling left    10 000 pieces/reel Unrolling left reversed    10 000 pieces/reel Unrolling right reversed</p> <p style="text-align: center;">for HARTING tools</p>		

D-Sub

<sup>1)</sup> Minimum order 500 pieces or multiples of 500  
 Insertion and removal tool see chapter 20  
 Contact dimensions see page 05.31

Crimp contacts



Identification

Drawing

Dimensions in mm

Female contacts

For banded contacts only

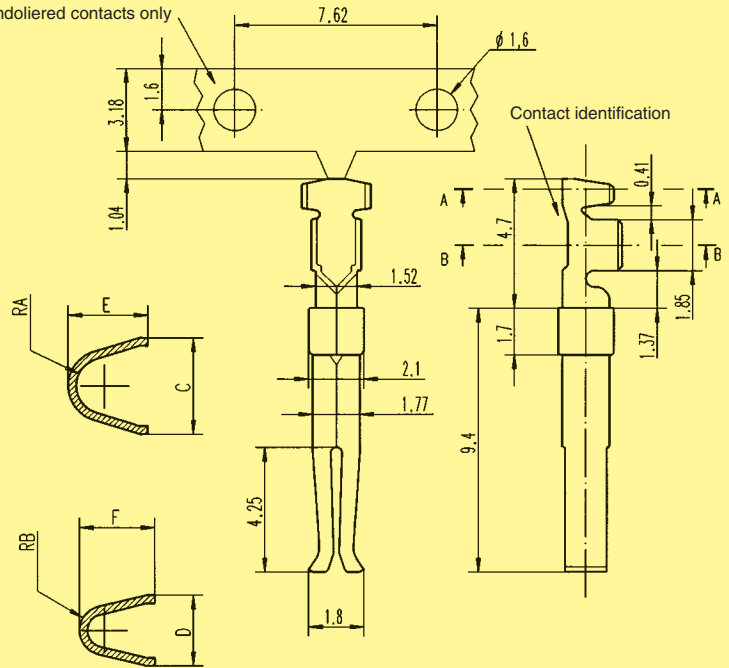

AWG	C	D	E	F	RA	RB	Contact identification
20-24	2.46	1.78	1.98	1.90	0.71	0.43	—
24-28	1.65	1.47	1.52	1.52	0.50	0.33	≡≡≡

D-Sub



Number of contacts

**9–37**



Insulation displacement termination

Identification	No. of contacts	Part No.	
		Performance level 3	Performance level 2
<b>Performance levels</b> Explanations see page 05.04 Other performance levels on request			
<b>Male connector</b> pitch 1.27 mm metal shell with dimples	9 15 25 37	09 66 128 770 . 09 66 228 770 . 09 66 328 770 . 09 66 428 770 .	09 66 128 670 . 09 66 228 670 . 09 66 328 670 . 09 66 428 670 .
<b>Female connector</b> pitch 1.27 mm metal shell	9 15 25 37	09 66 118 750 . 09 66 218 750 . 09 66 318 750 . 09 66 418 750 .	09 66 118 650 . 09 66 218 650 . 09 66 318 650 . 09 66 418 650 .
Please insert digit for flange thread or fitted female screw locks ø 3.1 mm hole  0 M3  1 <sup>1)</sup> 4-40 UNC  2			
<b>Strain relief clamp</b> plastic for male and female connector	9 15 25 37	09 66 108 0001 09 66 208 0001 09 66 308 0001 09 66 408 0001	09 66 108 0001 09 66 208 0001 09 66 308 0001 09 66 408 0001

D-Sub

<sup>1)</sup> Not normally kept in stock

Number of contacts

# 9-37



Insulation displacement termination

Identification

Drawing

Dimensions in mm

Male connector

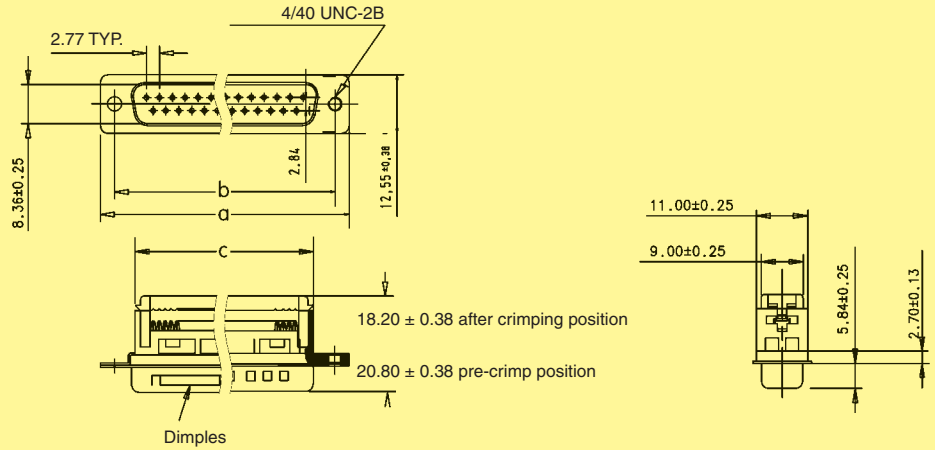

Female connector

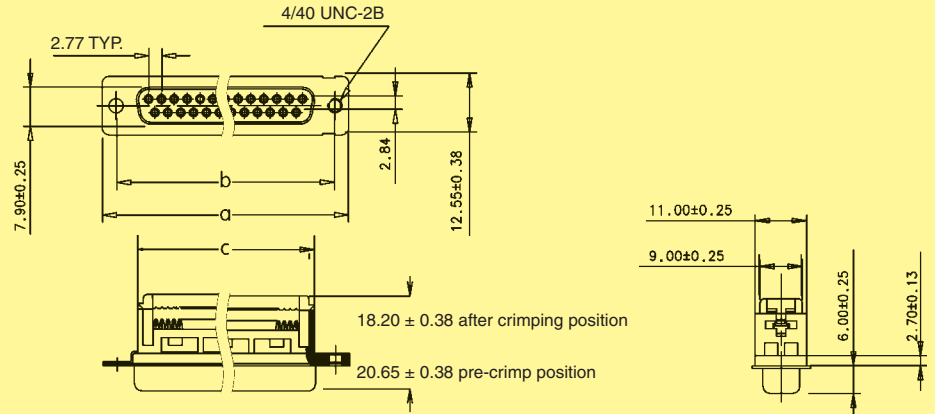

Male and female connectors

	a	b±0.1	c
9	30.80	24.99	16.10
15	39.10	33.32	24.00
25	53.09	47.04	38.14
37	69.40	63.50	54.60

Specified conductors  
 stranded wires – AWG 28/7  
 – AWG 26/7  
 solid wires – AWG 30/1  
 – AWG 28/1

Strain relief clamps

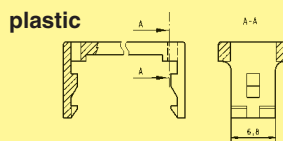

Panel cut out for front/rear mount

Values are taken from the CECC 75 301-802

see page 05.24

D-Sub

Number of contacts

# 9–50



Solder buckets

Identification	No. of contacts	Part No.		
<b>Performance levels</b> Explanations see page 05.04 Other performance levels on request		Performance level 3	Performance level 2	
<b>Male connector</b> metal shell with dimples	9 15 25 37 50	turned contacts	turned contacts	
		09 67 009 5604	09 67 009 5615	
		09 67 015 5604	09 67 015 5615	
		09 67 025 5604	09 67 025 5615	
		09 67 037 5604	09 67 037 5615	
		09 67 050 5604 <sup>1)</sup>	09 67 050 5615	
		stamped contacts	stamped contacts	
		09 67 209 5604	09 67 209 5615	
		09 67 215 5604	09 67 215 5615	
		09 67 225 5604	09 67 225 5615	
	09 67 237 5604	09 67 237 5615		
	09 67 250 5604 <sup>1)</sup>	09 67 250 5615 <sup>1)</sup>		
	<b>Female connector</b> metal shell	9 15 25 37 50	turned contacts	turned contacts
			09 67 009 4704	09 67 009 4715
09 67 015 4704			09 67 015 4715	
09 67 025 4704			09 67 025 4715	
09 67 037 4704			09 67 037 4715	
09 67 050 4704 <sup>1)</sup>			09 67 050 4715	
stamped contacts			stamped contacts	
09 67 209 4704			09 67 209 4715	
09 67 215 4704			09 67 215 4715	
09 67 225 4704			09 67 225 4715	
09 67 237 4704	09 67 237 4715			
09 67 250 4704 <sup>1)</sup>	09 67 250 4715 <sup>1)</sup>			

D-Sub

<sup>1)</sup> Not normally kept in stock

Number of contacts  
**9-50**



Solder buckets

Identification

Drawing

Dimensions in mm

Male connector

**9-37**

**50**

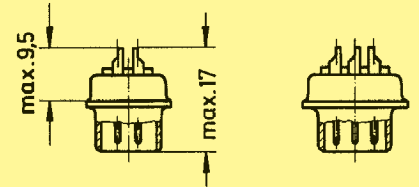
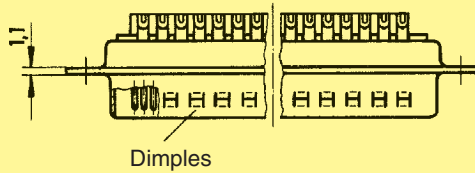
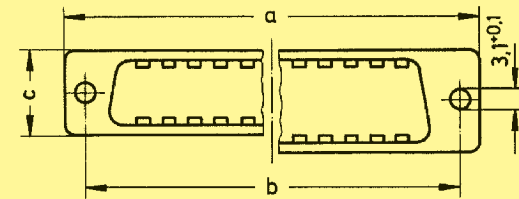

Female connector

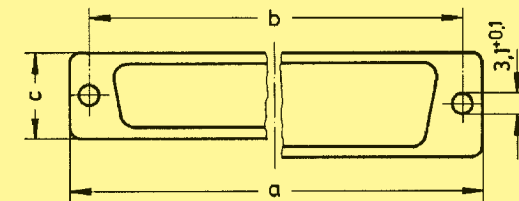
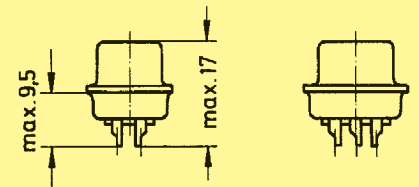
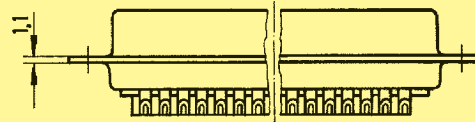

**9-37**

**50**

	a	b <sub>±0.1</sub>	c
9	30.9	25.0	12.5
15	39.2	33.3	12.5
25	53.1	47.0	12.5
37	69.4	63.5	12.5
50	67.0	61.1	15.4

Panel cut out  
for front/rear mount

Values are taken from the  
CECC 75 301-802

see page 05.24

Number of contacts 15, 26, 44, 62, 78  
UL recognized

Working current  
Stamped contacts 2 A max.

Test voltage  $U_{r.m.s.}$  1 kV

Clearance and creepage  $\geq 1.0$  mm

Contact resistance  $\leq 20$  m $\Omega$   
Insulation resistance  $\geq 5 \times 10^9$   $\Omega$

Temperature range -55 °C ... + 105 °C  
The higher temperature limit includes the local ambient and heating effect of the contacts under load

Terminations

- a) Solder pins  $\varnothing$  0.65 mm for P.C.B. holes  $\varnothing$  1.02 mm
- b) Solder pins, angled 90°  $\varnothing$  0.7 mm for P.C.B. holes  $\varnothing$  1.02 mm
- c) Crimp contacts 0.14 - 0.22 mm<sup>2</sup> AWG 26 - 24 max. insulation  $\varnothing$  1.38 mm
- d) Solder cups AWG 22

Materials  
Mouldings and hoods Thermoplastic resin, glass-fibre filled (PBTP), UL 94-V0

Contacts Copper alloy

Contact surface  
Contact zone selectively gold-plated according to performance level<sup>1)</sup>

Metal shell Plated steel

Mating force

- 15 way  $\leq 46$  N
- 26 way  $\leq 77$  N
- 44 way  $\leq 127$  N
- 62 way  $\leq 177$  N
- 78 way  $\leq 222$  N

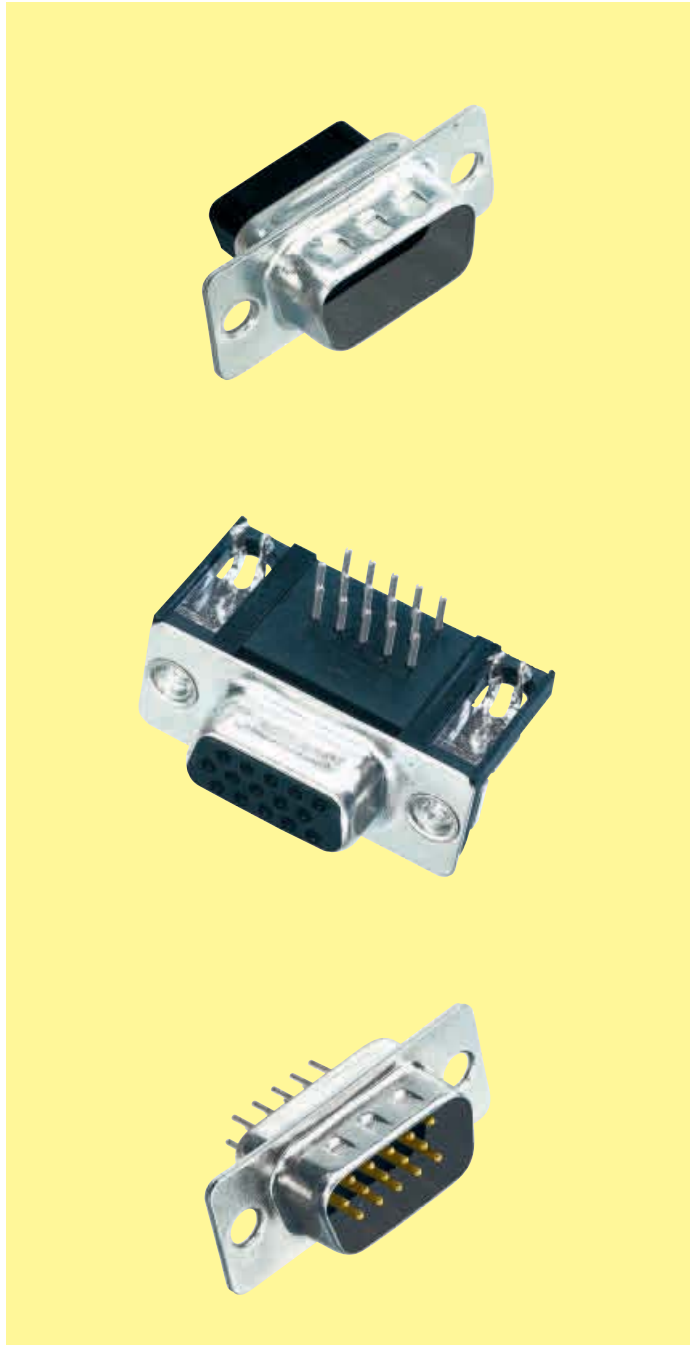

Number of contacts in the D-Sub standard/D-Sub high density range related to the shell size.

Shell size	D-Sub standard	D-Sub high density
1	9	15
2	15	26
3	25	44
4	37	62
5	50	78

<sup>1)</sup> Performance level 3, 50 mating cycles, no gas test S4, plating  $\geq 0.76$   $\mu$ m Au (30  $\mu$ inch)

Number of contacts

# 15-78

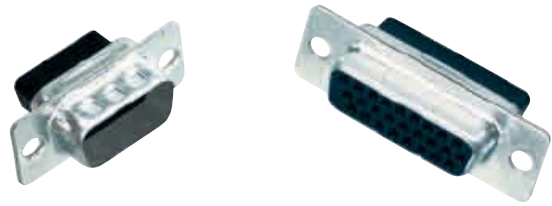

High density crimp terminal

Identification	No. of contacts	Part No.
Male connector Order contacts separately  metal shell with dimples	15	09 56 100 5601
	26	09 56 200 5601
	44	09 56 300 5601
	62	09 56 400 5601
	78	09 56 500 5601
Female connector Order contacts separately  metal shell	15	09 56 100 4701
	26	09 56 200 4701
	44	09 56 300 4701
	62	09 56 400 4701
	78	09 56 500 4701

D-Sub

Male connector

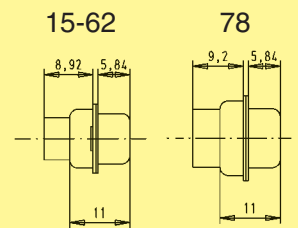
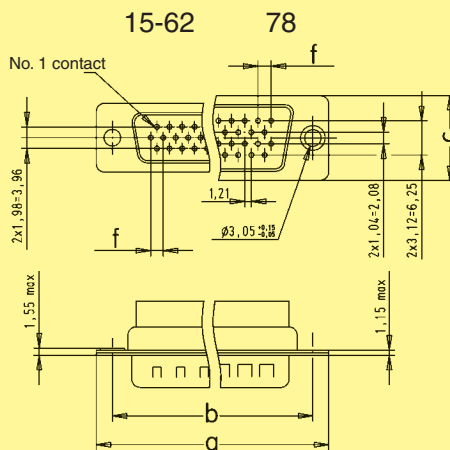

	a	b $\pm 0.13$	c	f
15	30.9	25.0	12.5	2.29
26	39.2	33.3	12.5	2.29
44	53.1	47.0	12.5	2.29
62	69.4	63.5	12.5	2.41
78	67.0	61.1	15.4	2.41

Female connector

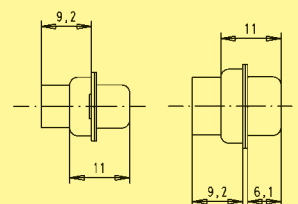
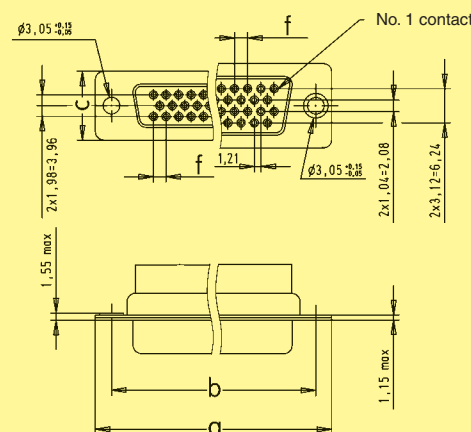

Panel cut out for front/rear mount

Values are taken from the CECC 75301-802

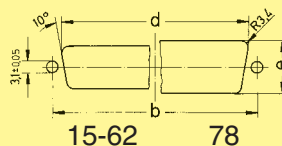

	Front mount			Rear mount			
	b $\pm 0.13$	d $\pm 0.2$	e $\pm 0.2$	b $\pm 0.13$	d $\pm 0.2$	e $\pm 0.2$	
15	25.0	22.2	12.3	15	25.0	20.5	11.4
26	33.3	30.5	12.3	26	33.3	28.8	11.4
44	47.0	44.3	12.3	44	47.0	42.5	11.4
62	63.5	60.7	12.3	62	63.5	59.1	11.4
78	61.1	58.3	15.1	78	61.1	56.3	14.1

Dimensions in mm

Crimp contacts for high density connectors



Identification	Wire gauge (mm <sup>2</sup> )	Part No.				
		stamped male contacts		stamped female contacts		
Performance levels Explanations see page 05.04 Other performance levels on request		Performance level 3	S4 <sup>1)</sup>	Performance level 3	S4 <sup>1)</sup>	
<b>D-Sub</b> 500 pieces/box	0.14-0.22 AWG 26-24 stranded	09 56 000 8177	09 56 000 8175	09 56 000 8277	09 56 000 8275	
		500 pieces/reel Unrolling left	09 56 000 8167	09 56 000 8165	09 56 000 8267	09 56 000 8265
		10 000 pieces/reel Unrolling left	09 56 000 8157	09 56 000 8155	09 56 000 8257	09 56 000 8255
Unrolling direction		<p>500 pieces/reel Unrolling left</p> <p>10 000 pieces/reel Unrolling left</p> <p>for HARTING tools</p>				

<sup>1)</sup> S4: ≥ 0.76 μm Au (30 μinch)  
Contact dimensions see page 05.39

Crimp contacts for high density connectors



Identification

Drawing

Dimensions in mm

Male contacts

wire gauge AWG 26-24

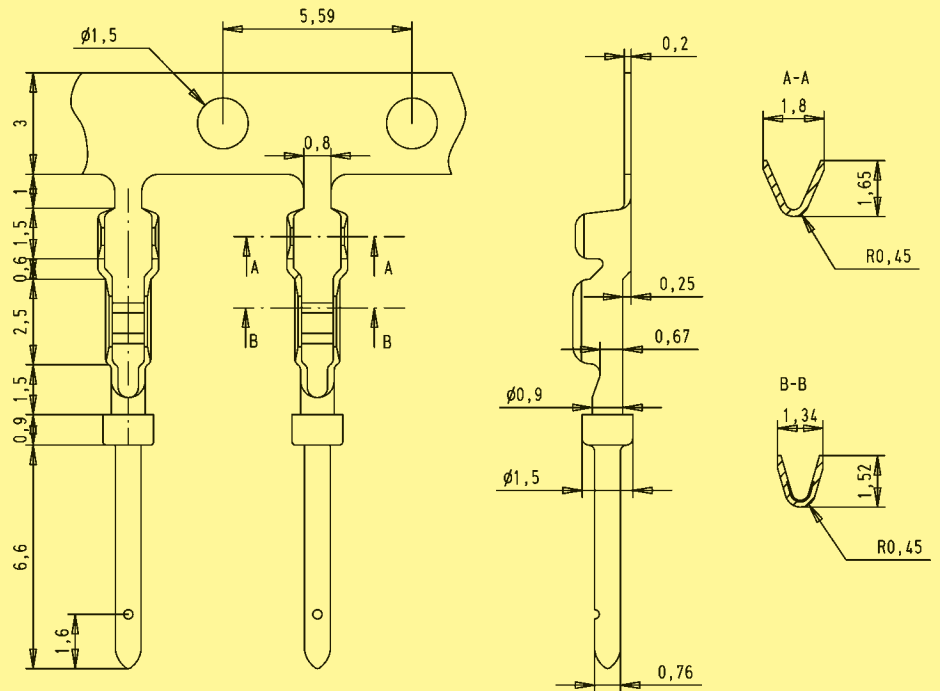

Female contacts

wire gauge AWG 26-24

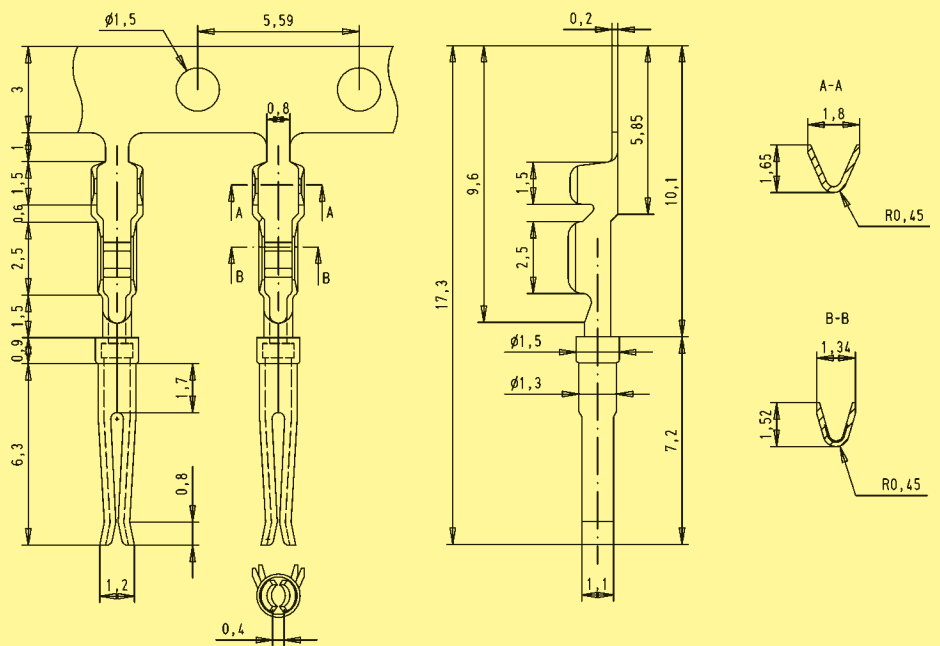



Number of contacts

15–78



High density with stamped solder cups, straight

Identification	No. of contacts	Part No.	Part No.
<b>Performance levels</b> Explanations see page 05.04 Other performance levels on request		Performance level 3	S4 <sup>1)</sup>
<b>Male connector</b> metal shell with dimples			
<b>Female connector</b> metal shell			
	15 26 44 62 78	09 56 100 5604 09 56 200 5604 09 56 300 5604 09 56 400 5604 09 56 500 5604	09 56 100 5615 050 09 56 200 5615 050 09 56 300 5615 050 09 56 400 5615 050 09 56 500 5615 050
	15 26 44 62 78	09 56 100 4704 09 56 200 4704 09 56 300 4704 09 56 400 4704 09 56 500 4704	09 56 100 4715 050 09 56 200 4715 050 09 56 300 4715 050 09 56 400 4715 050 09 56 500 4715 050

D-Sub

<sup>1)</sup> S4: ≥ 0.76 µm Au (30 µinch)

Number of contacts

# 15-78

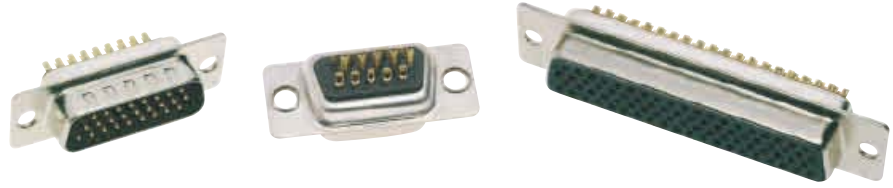

High density with stamped solder cups, straight

Identification

Drawing

Dimensions in mm

Male connector

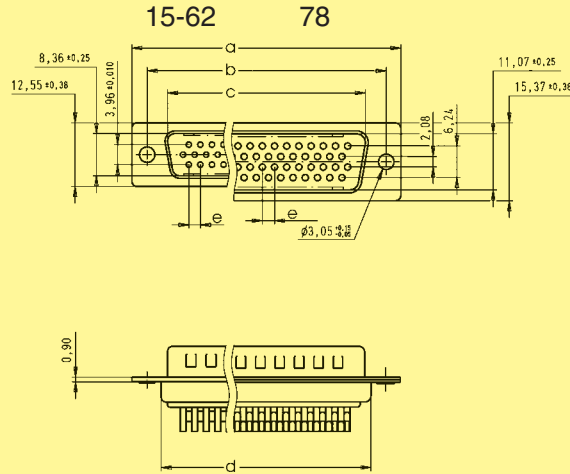

15-62

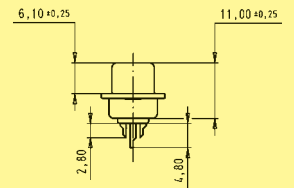

78

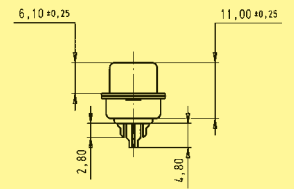

	a	b	c	d	e	f
15	30.89	24.99	16.92	19.28	2.29	16.33
26	39.10	33.32	25.25	27.51	2.29	24.66
44	53.09	47.04	38.96	41.30	2.29	38.38
62	69.40	63.50	55.25	57.71	2.42	54.84
78	66.93	61.11	52.81	55.32	2.42	52.43

Female connector

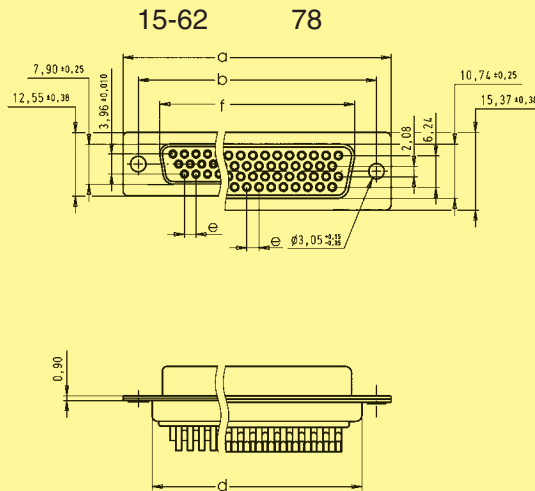

15-62

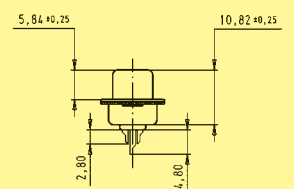

78

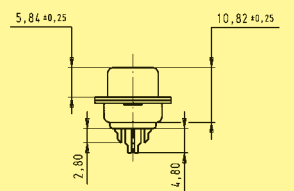

Number of contacts

# 15-78

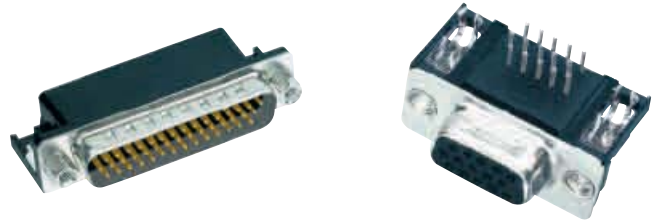

High density with stamped solder pins, angled with grounding board locks

Identification	No. of contacts	Performance level		Part No.	
<b>Performance levels</b> Explanations see page 05.04 Other performance levels on request		3		S4 <sup>1)</sup>	
<b>Male connector</b> metal shell with dimples					
	15	09 56 162 781 .		09 56 162 581 .	
	26	09 56 262 781 .		09 56 262 581 .	
	44	09 56 362 781 .		09 56 362 581 .	
	62	09 56 462 781 .		09 56 462 581 .	
<b>Female connector</b> metal shell					
	15	09 56 152 761 .		09 56 152 561 .	
	26	09 56 252 761 .		09 56 252 561 .	
	44	09 56 352 761 .		09 56 352 561 .	
	62	09 56 452 761 .		09 56 452 561 .	
	78	09 56 552 761 .		09 56 552 561 .	
Please insert digit for flange thread or fitted female screw locks					
4-40 UNC ▶ 2					
fitted screw locks 4-40 UNC ▶ 3					

D-Sub

<sup>1)</sup> S4: ≥ 0.76 µm Au (30 µinch)

Number of contacts

# 15-78

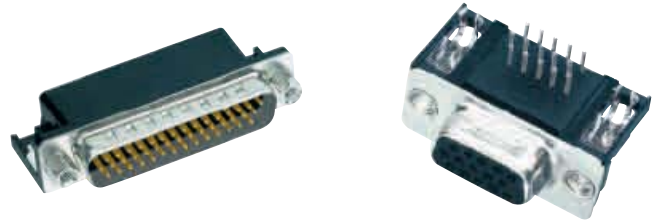

High density with stamped solder pins, angled with grounding board locks

Identification

Drawing

Dimensions in mm

Male connector

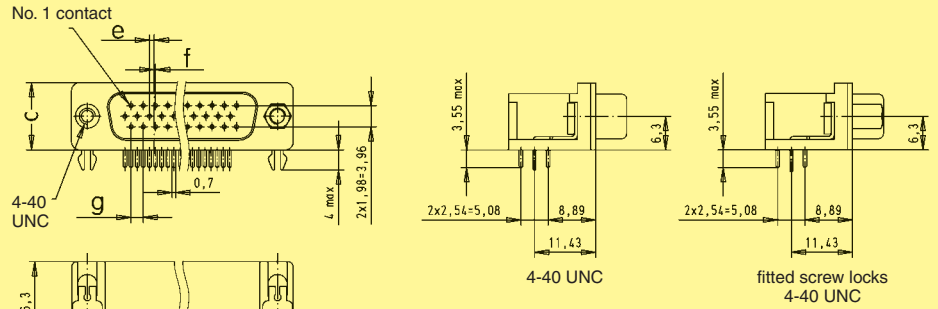

	a	b±0.1	c	e	f	g
15	30.9	25.0	12.5	0.89	0.25	2.29
26	39.2	33.3	12.5	0.64	0.51	2.29
44	53.1	47.0	12.5	0.64	0.51	2.29
62	69.4	63.5	12.5	0.62	0.58	2.41
78	67.0	61.1	15.4	-	-	2.41

Female connector

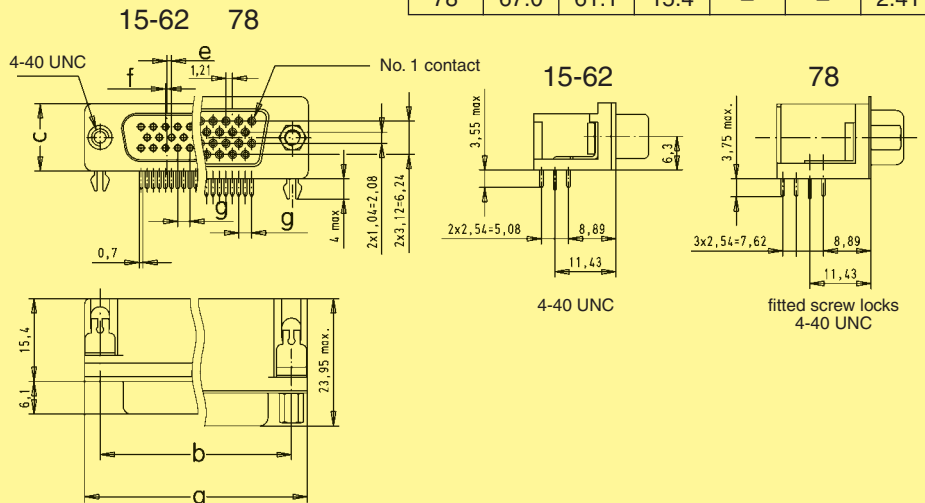

female 15-62

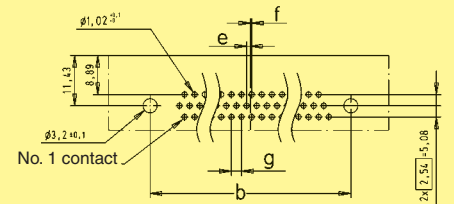

female 78

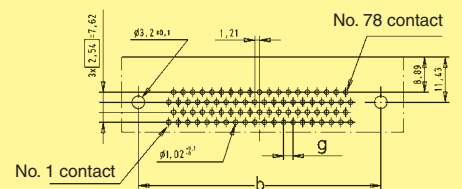

Board drillings

male

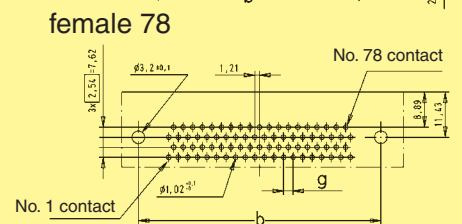
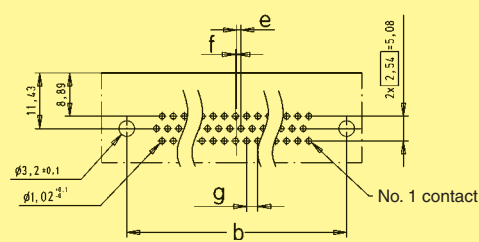



Number of contacts

# 15-78



High density with stamped solder pins, straight

Identification	No. of contacts	Part No.	
<b>Performance levels</b> Explanations see page 05.04 Other performance levels on request		Performance level <b>3</b>	S4 <sup>1)</sup>
<b>Male connector</b> metal shell with dimples	15 26 44 62 78	09 56 161 7700 09 56 261 7700 09 56 361 7700 09 56 461 7700 09 56 561 7700	09 56 161 5700 09 56 261 5700 09 56 361 5700 09 56 461 5700 09 56 561 5700
<b>Female connector</b> metal shell	15 26 44 62 78	09 56 151 7500 09 56 251 7500 09 56 351 7500 09 56 451 7500 09 56 551 7500	09 56 151 5500 09 56 251 5500 09 56 351 5500 09 56 451 5500 09 56 551 5500

D-Sub

Male connector

15-62 78                      15-62 78

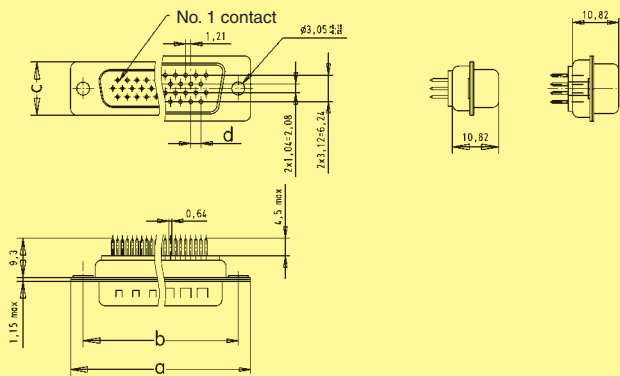

Female connector

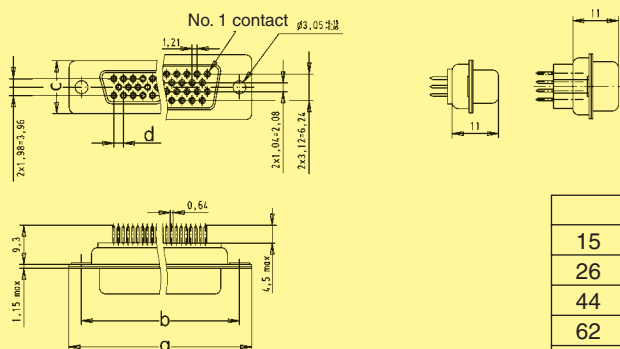

	a	b <sub>±0.1</sub>	c	d
15	30.9	25.0	12.5	2.29
26	39.2	33.3	12.5	2.29
44	53.1	47.0	12.5	2.29
62	69.4	63.5	12.5	2.41
78	67.0	61.1	15.4	2.41

Board drillings

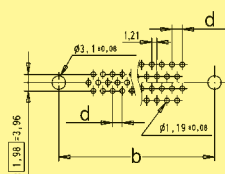

Dimensions in mm

<sup>1)</sup> S4: ≥ 0.76 μm Au (30 μinch)

Number of contacts

# 15-78

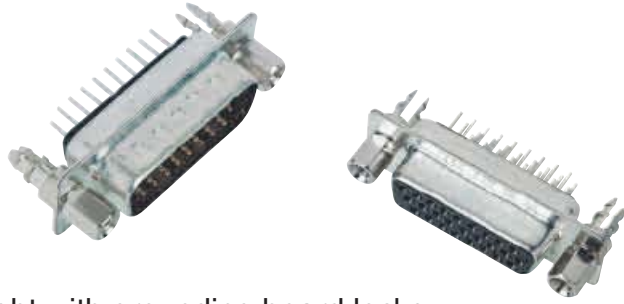

High density with stamped solder pins, straight with grounding board locks

Identification	No. of contacts	Part No.	
<b>Performance levels</b> Explanations see page 05.04 Other performance levels on request		<b>Performance level 3</b>	
		<b>S4<sup>1)</sup></b>	
<b>Male connector</b> metal shell with dimples			
	15	09 56 161 771 .	09 56 161 571 .
	26	09 56 261 771 .	09 56 261 571 .
	44	09 56 361 771 .	09 56 361 571 .
	62	09 56 461 771 .	09 56 461 571 .
	78	09 56 561 771 .	09 56 561 571 .
<b>Female connector</b> metal shell			
	15	09 56 151 751 .	09 56 151 551 .
	26	09 56 251 751 .	09 56 251 551 .
	44	09 56 351 751 .	09 56 351 551 .
	62	09 56 451 751 .	09 56 451 551 .
	78	09 56 551 751 .	09 56 551 551 .
Please insert digit for flange thread or fitted female screw locks			
4-40 UNC  2			
fitted screw locks 4-40 UNC  3			

D-Sub

<sup>1)</sup> S4: ≥ 0.76 µm Au (30 µinch)

Number of contacts

# 15-78



High density with stamped solder pins, straight with grounding board locks

Identification

Drawing

Dimensions in mm

Male connector

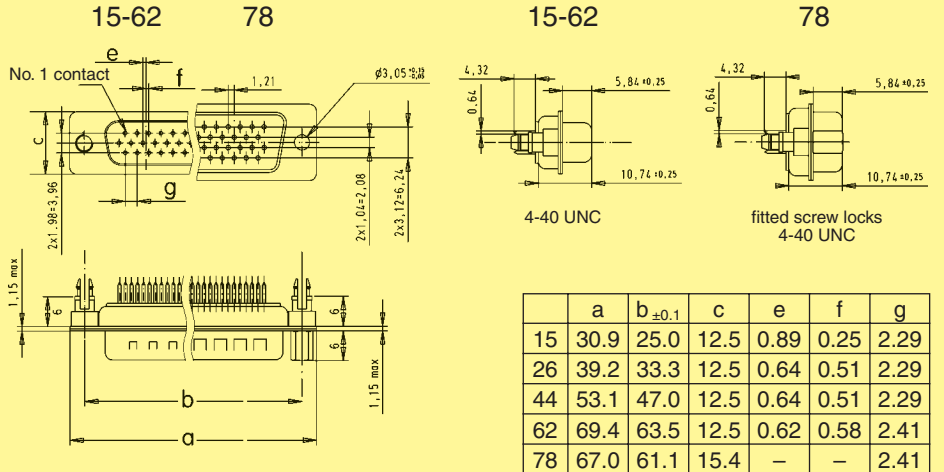

Female connector

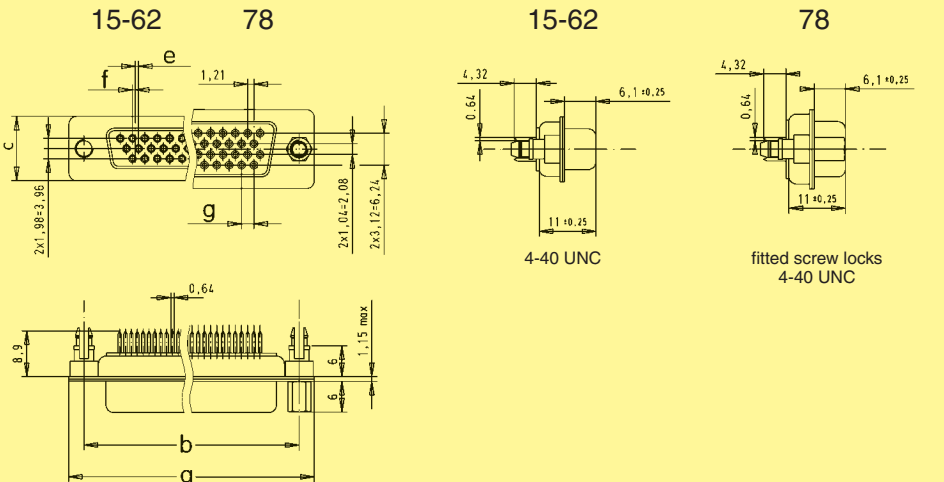

Board drillings

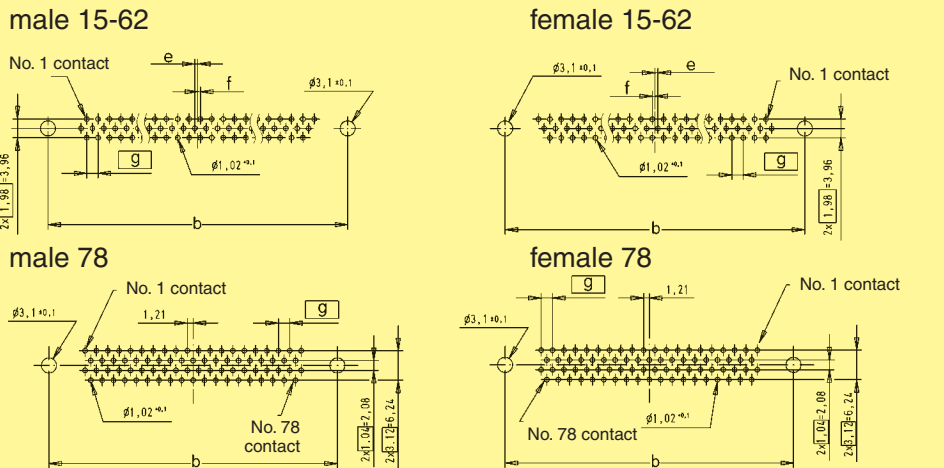



HARTINGs' mixed D-Sub range brings the advantage of an industry standard I/O interconnect product with the possibility to customise for any application.

The range is designed around **the standard D-Sub shell sizes** with **the possibility to have a blend of contacts** such as signals with coaxial, power, high voltage or pneumatic contacts. Due to its construction, the product is **fully shielded** and helps reducing the EMI/RFI leakage.

All contacts are machined with two different platings.

When hot plug-in is required, **first mate last break** contacts can also be supplied.

For connectors to be fitted on a board with SMT components, they can be supplied in an **SMC (PiHIR) version** which is assembled in the reflow solder process, thus reducing assembly cost.

In addition, a complete range of accessories such as clinch nut, spacers, board locks, female screw lock, etc. ... meeting the requirements of virtually any application, including a blind mate feature, makes this product range very attractive thanks to its versatility, reliability and cost effectiveness.



## Contact arrangements

The table shows the standard range supported by HARTING. Two versions are special since they allow to mix in the same shell male and female contacts: 2W2C and 3W3C. The purpose of these versions is to have a 100 % mating proof feature (the insulator shape prevents a 180° reversed mating).

The structure of the connectors' identification is so that the left side digits give the total number of contacts and the right side digits the number of special contacts which can be either power, coaxial or high voltage style.

Example: 13W3 stands for 13 contacts in total with 10 signal contacts and 3 special contacts.

	Shell size	
2W2C	1	
5W1	1	
3W3	2	
3W3C	2	
7W2	2	
11W1	2	
5W5	3	
9W4	3	
13W3	3	
17W2	3	
21W1	3	

	Shell size	
7W7	4	
8W8	4	
13W6	4	
21WA4	4	
25W3	4	
27W2	4	
24W7	5	
36W4	5	

Note: for any other layout please consult your HARTING representative.

Connectors for pcb applications – general information

The range of pcb connectors available at HARTING is summarised in the table under. For each of the basic connector versions, the available contact styles are documented with termination process, pitch, plating, rating for power contacts and impedance for coaxial contact etc..., as well as the accessory configuration.

**Pcb connectors are delivered fully loaded** thus providing a very good positioning of the contacts in their cavities for an easy and safe insertion of the pins in the pcb holes particularly crucial in the right angled versions.



Due to the numerous possibilities offered with the pcb connectors, suggested method is to contact your local HARTING representative to determine the part number to order; see customer request form on pages 05.86 and 05.87.

	Straight		Right angled	
<b>Insulator body</b>	<ul style="list-style-type: none"> <li>• Standard</li> <li>• SMC: Solder Reflow Compatible</li> </ul>		<ul style="list-style-type: none"> <li>• Standard</li> <li>• SMC: Solder Reflow Compatible</li> </ul>	
<b>Signal contacts</b>	<b>Solder termination</b> <ul style="list-style-type: none"> <li>• Pitch: 2.84 mm</li> <li>• Plating: 0.76 µm Au over Ni</li> <li>• Pcb thickness from 1.6 to 3.2 mm</li> </ul>		<b>Solder termination</b> <ul style="list-style-type: none"> <li>• Pitch: 2.54 mm</li> <li>• Plating: 0.76 µm Au over Ni</li> <li>• Pcb thickness from 1.6 to 3.2 mm</li> </ul>	
<b>Power contacts</b>	<b>Solder termination</b> <ul style="list-style-type: none"> <li>• Rating: 20, 30, 40 A</li> <li>• Plating: 0.76 µm Au over Ni</li> </ul> <b>Press-in termination</b> <ul style="list-style-type: none"> <li>• Rating: 30 A</li> <li>• Plating: 0.76 µm Au over Ni</li> </ul>		<b>Solder termination</b> <ul style="list-style-type: none"> <li>• Rating: 20, 30, 40 A</li> <li>• Plating: 0.76 µm Au over Ni</li> </ul>	
<b>Coaxial contacts</b>	<b>Solder termination</b> <ul style="list-style-type: none"> <li>• 50 or 75 Ω</li> <li>• Plating: 1.3 µm Au over Ni inner conductor 0.76 µm Au over Ni outer ring</li> </ul>		<b>Solder termination</b> <ul style="list-style-type: none"> <li>• 50 or 75 Ω</li> <li>• Plating: 1.3 µm Au over Ni inner conductor 0.76 µm Au over Ni outer ring</li> </ul>	
<b>Accessories</b>	Through hole		Metal bracket with board lock and through hole	
	Nut: M3 or UNC 4-40		Metal bracket with board lock and clinch nut M3 or UNC 4-40	
	Spacer: M3 or UNC 4-40		Metal bracket with board lock and female screw lock UNC 4-40	
	Spacer (M3 or UNC 4-40) with board lock			
	Spacer + board lock + female screw lock M3 or UNC 4-40			

D-Sub

Connectors for cable applications – general information

Two termination processes are available: crimp or solder

<p><b>Shell</b></p>		
<p><b>Signal contacts</b></p>	<p><b>Crimp termination</b></p> <ul style="list-style-type: none"> <li>• For wire gauge: AWG 20-24 or 26-28</li> <li>• Plating: 0.76 µm or 0.2 µm Au over Ni</li> </ul>	<p><b>Pre-mounted solder cup contacts</b></p> <ul style="list-style-type: none"> <li>• Plating: 0.76 µm or 0.1 µm Au over Ni</li> </ul>
<p><b>Power contacts</b></p>	<p><b>Crimp</b></p> <ul style="list-style-type: none"> <li>• Rating: 10, 20, 30, 40 A</li> <li>• Plating: 0.76 µm or 0.2 µm Au over Ni</li> </ul> <p><b>Solder cup</b></p> <ul style="list-style-type: none"> <li>• Rating: 10, 20, 30, 40 A</li> <li>• Plating: 0.76 µm or 0.2 µm Au over Ni</li> </ul>	<p><b>Crimp</b></p> <ul style="list-style-type: none"> <li>• Rating: 10, 20, 30, 40 A</li> <li>• Plating: 0.76 µm or 0.2 µm Au over Ni</li> </ul> <p><b>Solder cup</b></p> <ul style="list-style-type: none"> <li>• Rating: 10, 20, 30, 40 A</li> <li>• Plating: 0.76 µm or 0.2 µm Au over Ni</li> </ul>
<p><b>Coaxial contacts<sup>1)</sup></b></p>	<p><b>Solder/crimp termination</b></p> <ul style="list-style-type: none"> <li>• 50 or 75 Ω</li> <li>• Plating: 1.3 µm or 0.2 µm Au over Ni inner conductor 0.76 µm or 0.2 µm Au over Ni outer ring</li> <li>• Cables: RG 178, 179 ...</li> </ul> <p><b>Crimp/crimp termination</b></p> <ul style="list-style-type: none"> <li>• 50 or 75 Ω</li> <li>• Plating: 1.3 µm or 0.2 µm Au over Ni inner conductor 0.76 µm or 0.2 µm Au over Ni outer ring</li> <li>• Cables: RG 178, 179 ...</li> </ul>	<p><b>Solder/crimp termination</b></p> <ul style="list-style-type: none"> <li>• 50 or 75 Ω</li> <li>• Plating: 1.3 µm or 0.2 µm Au over Ni inner conductor 0.76 µm or 0.2 µm Au over Ni outer ring</li> <li>• Cables: RG 178, 179 ...</li> </ul> <p><b>Crimp/crimp termination</b></p> <ul style="list-style-type: none"> <li>• 50 or 75 Ω</li> <li>• Plating: 1.3 µm or 0.2 µm Au over Ni inner conductor 0.76 µm or 0.2 µm Au over Ni outer ring</li> <li>• Cables: RG 178, 179 ...</li> </ul>
<p><b>High voltage contacts</b></p>	<p><b>Solder termination</b></p> <ul style="list-style-type: none"> <li>• Plating: 1.3 µm Au over Ni terminating and mating side</li> </ul>	<p><b>Solder termination</b></p> <ul style="list-style-type: none"> <li>• Plating: 1.3 µm Au over Ni terminating and mating side</li> </ul>

D-Sub

<sup>1)</sup> Coaxial contacts are provided in two versions:

- Inner conductor soldered and outer part crimped (solder/crimp termination)
- Both inner and outer part crimped (crimp/crimp termination); this version is recommended for medium or large size volume since crimping is faster than soldering.

Number of contacts 2, 3, 5, 7, 8, 9, 11, 13, 17, 21, 24, 25, 27, 36

Approvals DIN 41 652, part 1  
MIL-C 24 308

Working current 5 A for signal contacts

Temperature range -55 °C ... + 125 °C  
The higher temperature limit includes the ambient and heating effect of the contacts under load

Materials  
Mouldings Thermoplastic resin, glass-fibre filled (Polyester)  
UL 94-V0  
color: green for standard  
black for crimp

Metal shell Plated steel



Number of contacts

# 7-27



Mixed shells with pre-mounted signal solder cup contacts

Identification	No. of contacts <sup>1)</sup>	Part No.			
		male connectors		female connectors	
		Performance level 3	S4 <sup>2)</sup>	Performance level 3	S4 <sup>2)</sup>
	7W2	09 69 211 7072	09 69 211 5072	09 69 201 7072	09 69 201 5072
	17W2	09 69 311 7172	09 69 311 5172	09 69 301 7172	09 69 301 5172
	21WA4	09 69 411 7214	09 69 411 5214	09 69 401 7214	09 69 401 5214
	27W2	09 69 411 7272	09 69 411 5272	09 69 401 7272	09 69 401 5272

D-Sub

Male connectors

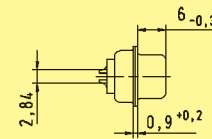
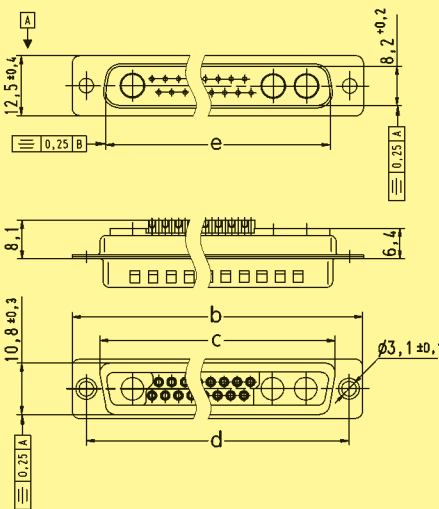

Solder cup termination for AWG 20 (0.5 mm<sup>2</sup>)

	a	b	c	d	e
7W2	24.6	39.1	27.5	33.30	25.2
17W2	38.3	53.0	41.3	47.04	38.9
21WA4	54.8	69.3	57.7	63.50	55.3
27W2	54.9	69.3	57.7	63.50	55.3

Female connectors

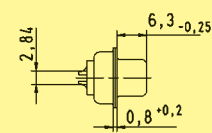
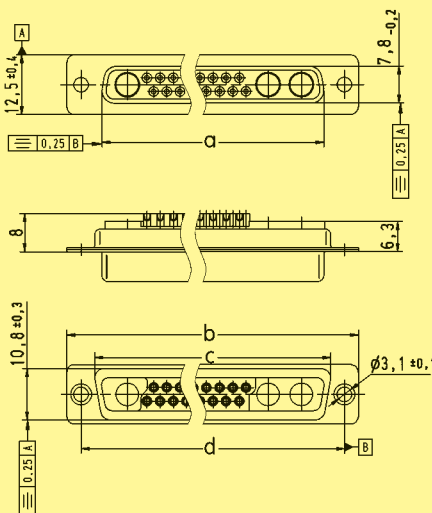

Solder cup termination for AWG 20 (0.5 mm<sup>2</sup>)

Dimensions in mm

<sup>1)</sup> Explanations see page 05.49  
<sup>2)</sup> S4: ≥ 0.76 μm Au

Board drillings see pages 05.76 ff  
 Order special contacts separately. See pages 05.67 ff

Number of contacts

# 9-25



Mixed shells with pre-mounted signal solder cup contacts

Identification	No. of contacts <sup>1)</sup>	Part No.			
		male connectors		female connectors	
		Performance level 3	S4 <sup>2)</sup>	Performance level 3	S4 <sup>2)</sup>
	9W4	09 69 311 7094	09 69 311 5094	09 69 301 7094	09 69 301 5094
	13W3	09 69 311 7133	09 69 311 5133	09 69 301 7133	09 69 301 5133
	25W3	09 69 411 7253	09 69 411 5253	09 69 401 7253	09 69 401 5253

Male connectors

**9W4**

Solder cup termination for AWG 20 (0.5 mm<sup>2</sup>)

**13W3, 25W3**

Solder cup termination for AWG 20 (0.5 mm<sup>2</sup>)

	b	c	d	e
13W3	53.0	41.3	47.04	38.90
25W3	69.3	57.7	63.50	49.84

Dimensions in mm

D-Sub

1) Explanations see page 05.49  
 2) S4: ≥ 0.76 μm Au  
 Board drillings see pages 05.76 ff

Drawings for female connectors see page 05.55  
 Order special contacts separately. See pages 05.67 ff

Number of contacts

# 9-25



Mixed shells with pre-mounted solder cup contacts

Identification

Drawing

Dimensions in mm

Female connectors

9W4

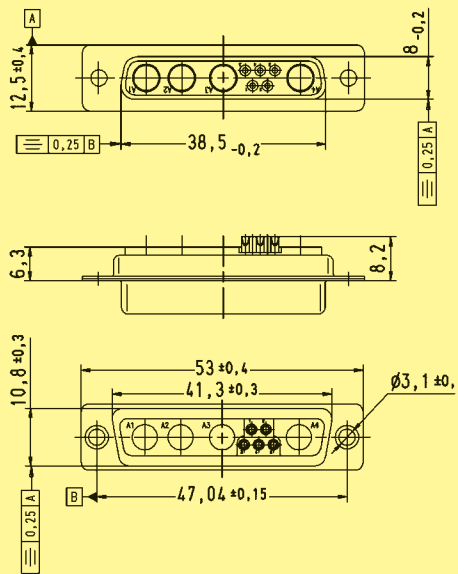

Solder cup termination for AWG 20 (0.5 mm<sup>2</sup>)

13W3, 25W3

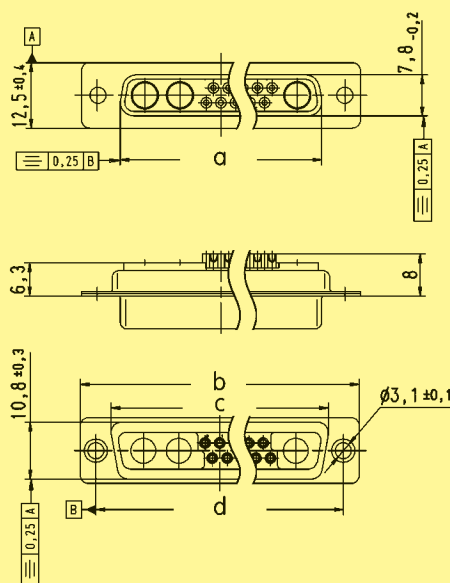

Solder cup termination for AWG 20 (0.5 mm<sup>2</sup>)

	a	b	c	d
13W3	38.3	53.0	41.3	47.04
25W3	54.9	69.3	57.7	63.50

D-Sub



Number of contacts

# 5-21



Mixed shells with pre-mounted signal solder cup contacts

Identification	No. of contacts <sup>1)</sup>	Part No.			
		male connectors		female connectors	
		Performance level 3	S4 <sup>2)</sup>	Performance level 3	S4 <sup>2)</sup>
	5W1	09 69 111 7051	09 69 111 5051	09 69 101 7051	09 69 101 5051
	11W1	09 69 211 7111	09 69 211 5111	09 69 201 7111	09 69 201 5111
	21W1	09 69 311 7211	09 69 311 5211	09 69 301 7211	09 69 301 5211

Male connectors

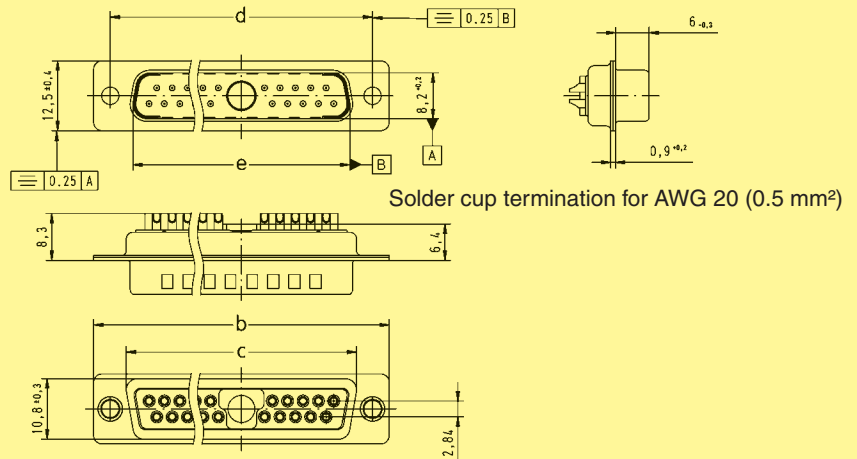

Female connectors

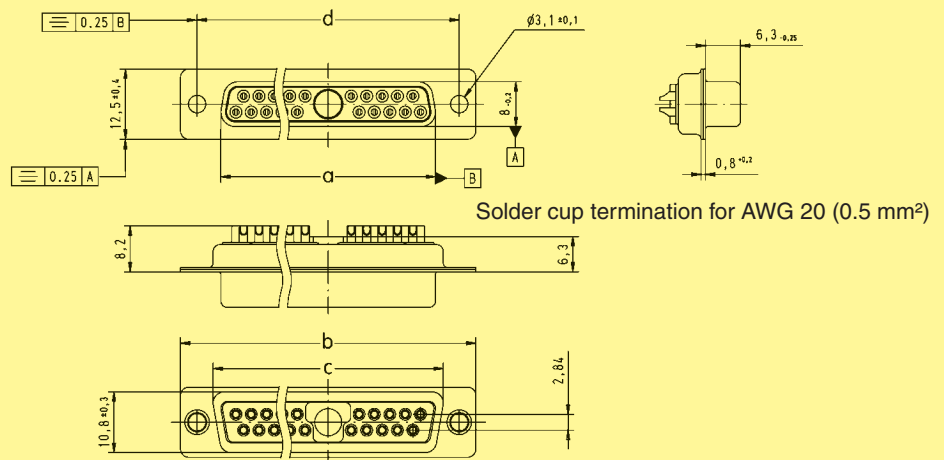

	a	b	c	d	e
5W1	16.4	30.8	19.3	25.00	16.9
11W1	24.7	39.1	27.5	33.30	25.2
21W1	38.5	53.0	41.3	47.04	38.9

Dimensions in mm

D-Sub

<sup>1)</sup> Explanations see page 05.49  
<sup>2)</sup> S4: ≥ 0.76 μm Au  
 Board drillings see pages 05.76 ff

Order special contacts separately. See pages 05.67 ff

Number of contacts

# 13



Mixed shells with pre-mounted signal solder cup contacts

Identification	No. of contacts <sup>1)</sup>	Part No.			
		male connectors		female connectors	
		Performance level 3	S4 <sup>2)</sup>	Performance level 3	S4 <sup>2)</sup>
	13W6	09 69 411 7136	09 69 411 5136	09 69 401 7136	09 69 401 5136

### Male connectors

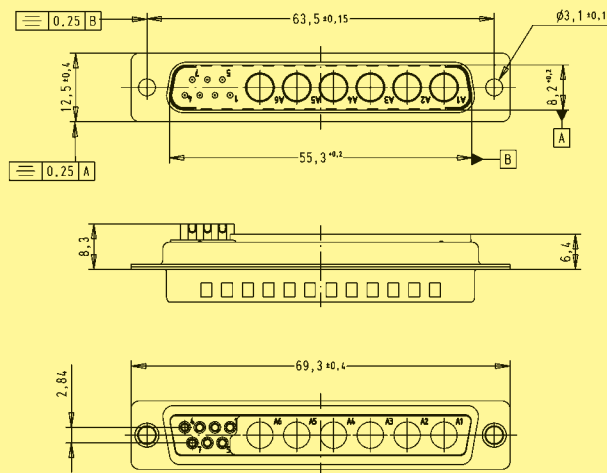

Solder cup termination for AWG 20 (0.5 mm<sup>2</sup>)

### Female connectors

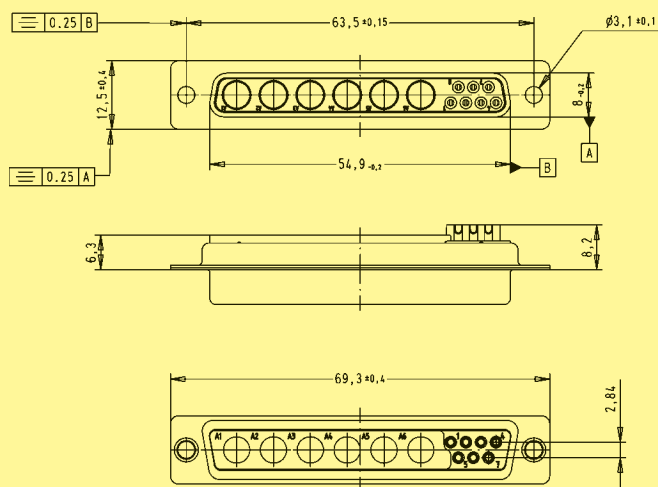

Solder cup termination for AWG 20 (0.5 mm<sup>2</sup>)

Dimensions in mm

D-Sub

<sup>1)</sup> Explanations see page 05.49  
<sup>2)</sup> S4: ≥ 0.76 µm Au  
 Board drillings see pages 05.76 ff

Order special contacts separately. See pages 05.67 ff

Number of contacts

# 24



Mixed shells with pre-mounted signal solder cup contacts

Identification	No. of contacts <sup>1)</sup>	male connectors		female connectors	
		Performance level 3	S4 <sup>2)</sup>	Performance level 3	S4 <sup>2)</sup>
	24W7	09 69 511 7247	09 69 511 5247	09 69 501 7247	09 69 501 5247

D-Sub

### Male connectors

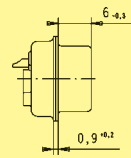
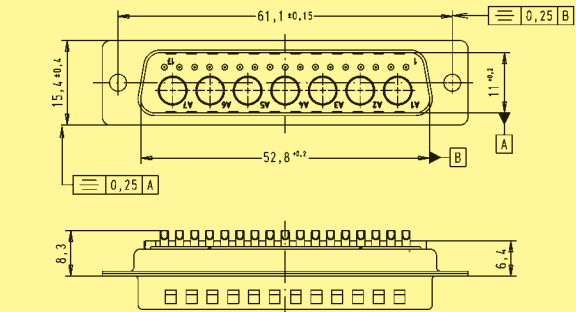

Solder cup termination for AWG 20 (0.5 mm<sup>2</sup>)

### Female connectors

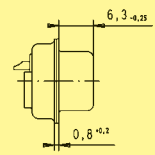
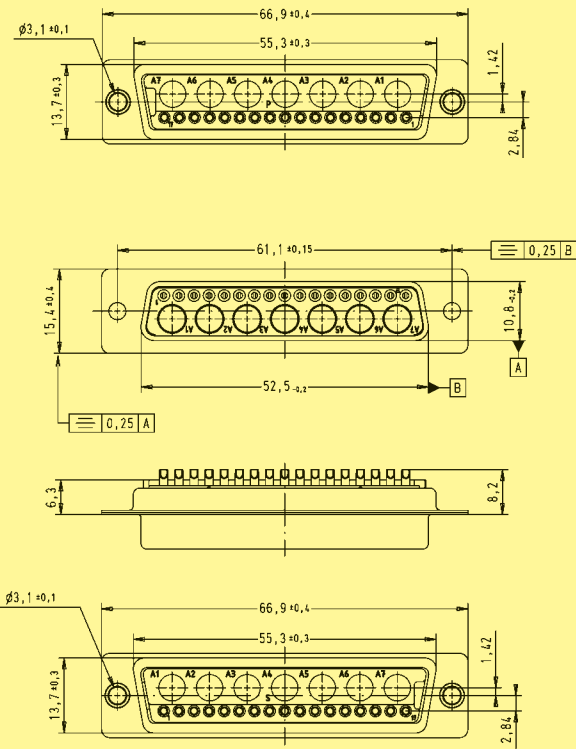

Solder cup termination for AWG 20 (0.5 mm<sup>2</sup>)

1) Explanations see page 05.49  
2) S4: ≥ 0.76 μm Au  
Board drillings see pages 05.76 ff

Order special contacts separately. See pages 05.67 ff

Number of contacts

# 36



Mixed shells with pre-mounted signal solder cup contacts

Identification	No. of contacts <sup>1)</sup>		Part No.	
	male connectors		female connectors	
	Performance level 3	S4 <sup>2)</sup>	Performance level 3	S4 <sup>2)</sup>
	36W4	09 69 511 7364	09 69 511 5364	09 69 501 7364

### Male connectors

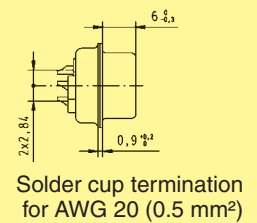
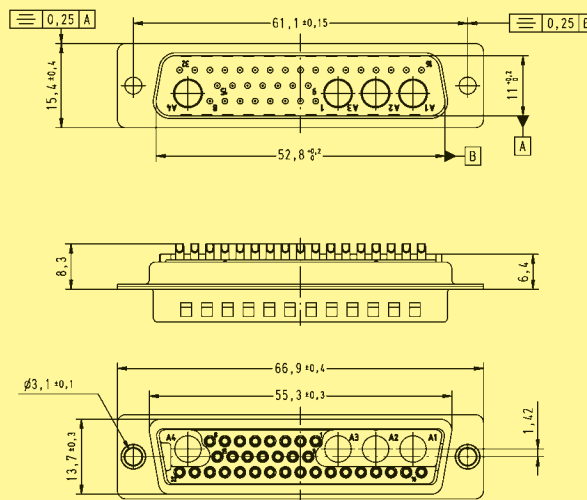

### Female connectors

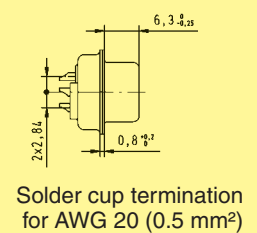
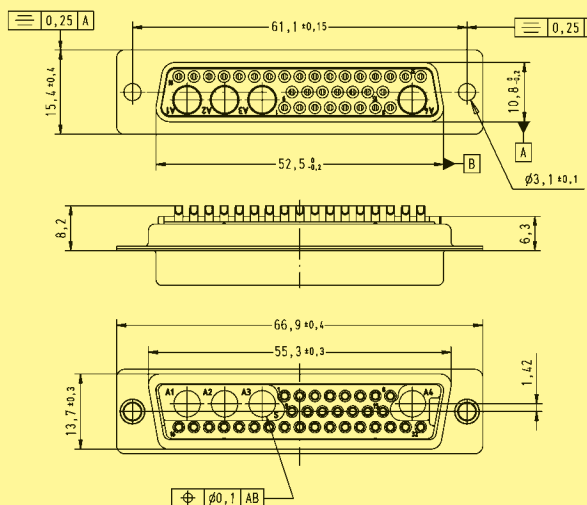

D-Sub

Dimensions in mm

<sup>1)</sup> Explanations see page 05.49  
<sup>2)</sup> S4: ≥ 0.76 μm Au  
 Board drillings see pages 05.76 ff

Order special contacts separately. See pages 05.67 ff

Number of contacts

**3-8**



Shells without signal contacts for cable applications

Identification	No. of contacts <sup>1)</sup>	Part No.	
		male connectors	female connectors
	3W3	09 69 210 0033	09 69 200 0033
	5W5	09 69 310 0055	09 69 300 0055
	7W7	09 69 410 0077	09 69 400 0077
	8W8	09 69 410 0088	09 69 400 0088

D-Sub

Male connectors

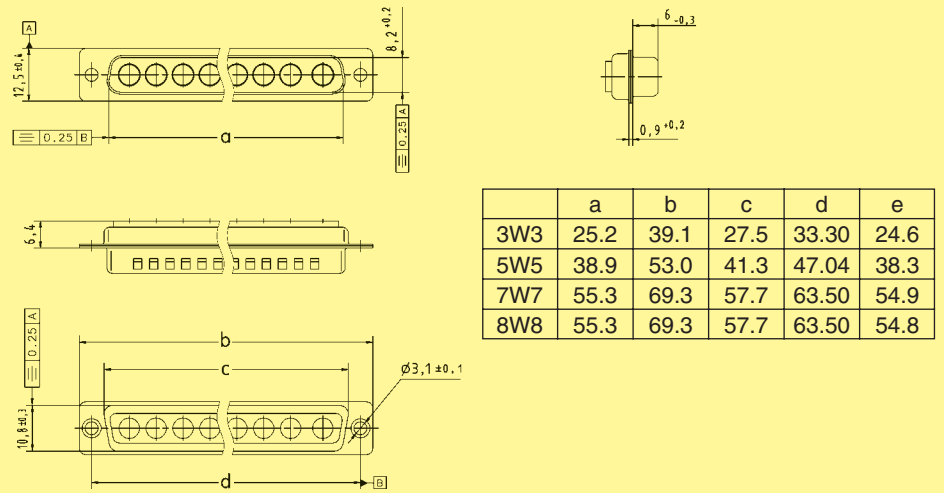

Female connectors

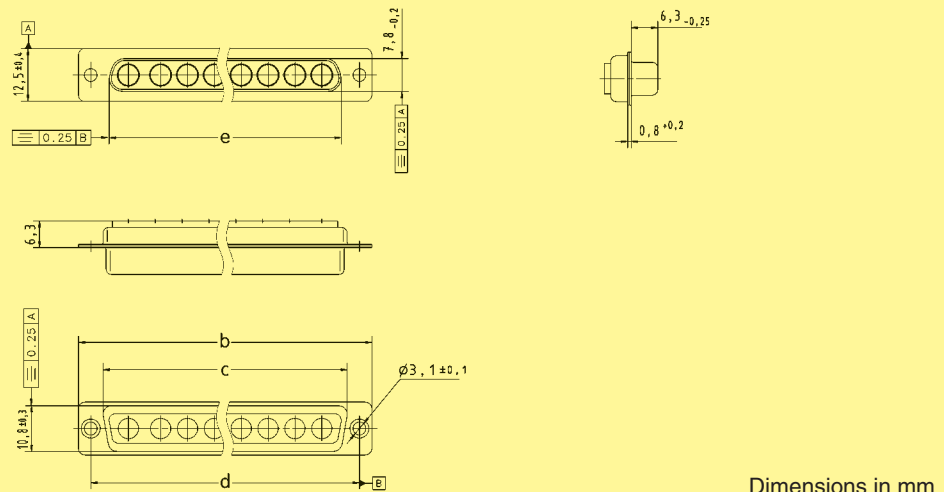

Dimensions in mm

<sup>1)</sup> Explanations see page 05.49  
 Board drillings see pages 05.76 ff  
 Order special contacts separately. See pages 05.67 ff

Number of contacts

2



Coded shells without signal contacts for cable applications

Identification	No. of contacts <sup>1)</sup>	Part No.
		male connector
	2W2C	09 69 110 0022
		female connector
		09 69 100 0022

Male connectors

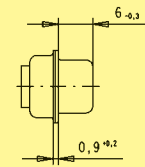
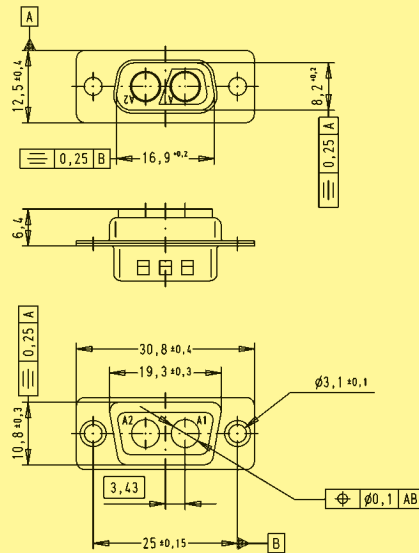

Female connectors

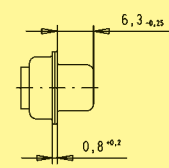
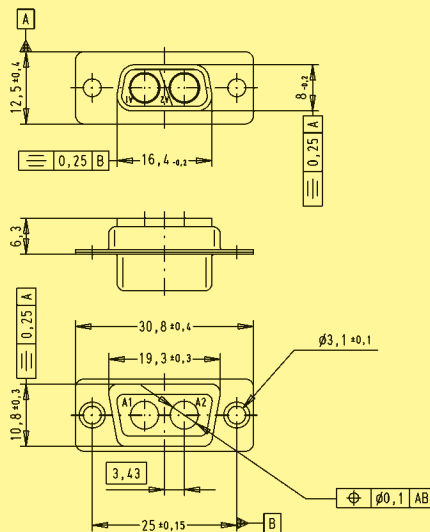

Dimensions in mm

D-Sub

<sup>1)</sup> Explanations see page 05.49  
 Board drillings see pages 05.76 ff  
 Order special contacts separately. See pages 05.67 ff

Number of contacts

3



Coded shells without signal contacts for cable applications

Identification	No. of contacts <sup>1)</sup>	Part No.	
		male connector	female connector
	3W3C	09 69 210 0633	09 69 200 0633

Male connectors

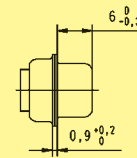
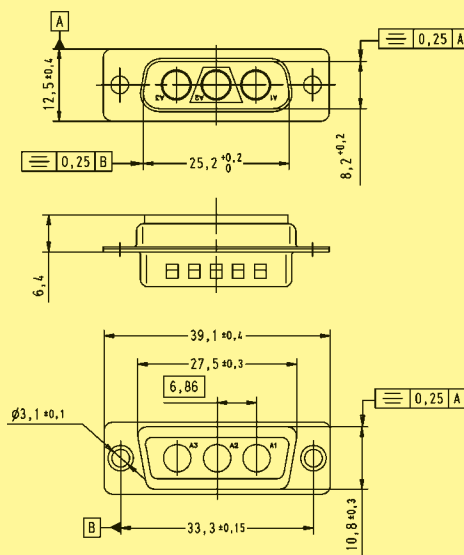

detail: polarization feature

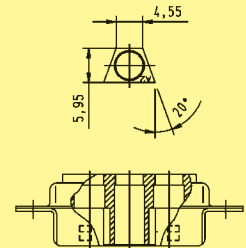

Female connectors

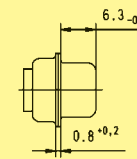
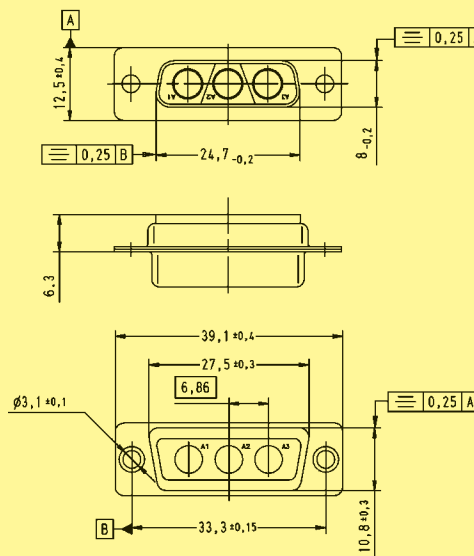

detail: polarization feature

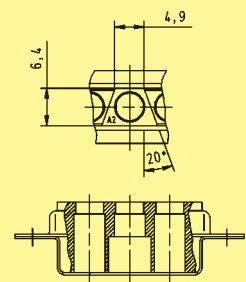

Dimensions in mm

<sup>1)</sup> Explanations see page 05.49  
Board drillings see pages 05.76 ff  
Order special contacts separately. See pages 05.67 ff

Number of contacts

# 7-21



Mixed shells for signal crimp contacts

Identification	No. of contacts <sup>1)</sup>	Part No.	Part No.
	7W2	male connectors 09 69 212 0072	female connectors 09 69 202 0072
	17W2	09 69 312 0172	09 69 302 0172
	21WA4	09 69 412 0214	09 69 402 0214

D-Sub

Male connectors

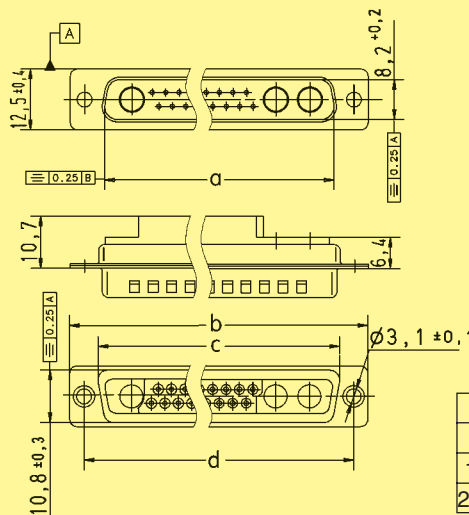

Female connectors

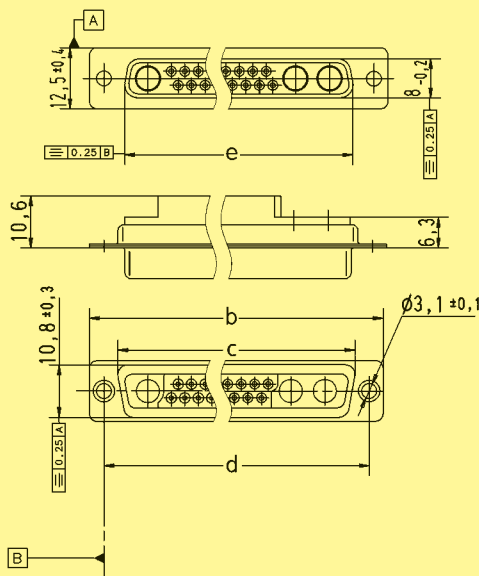

Dimensions in mm

<sup>1)</sup> Explanations see page 05.49  
 Board drillings see pages 05.76 ff  
 Order special contacts separately. See pages 05.67 ff



Number of contacts

# 13



Mixed shells for signal crimp contacts

Identification	No. of contacts <sup>1)</sup>	Part No.	
		male connector	female connector
	13W3	09 69 312 0133	09 69 302 0133

Male connectors

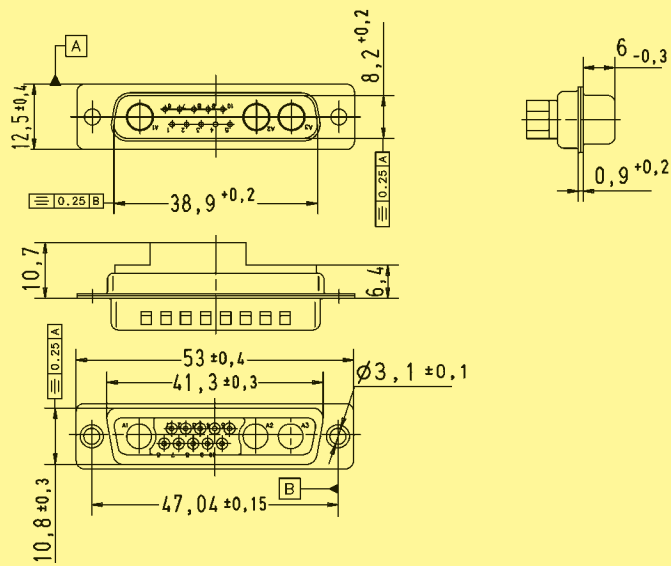

Female connectors

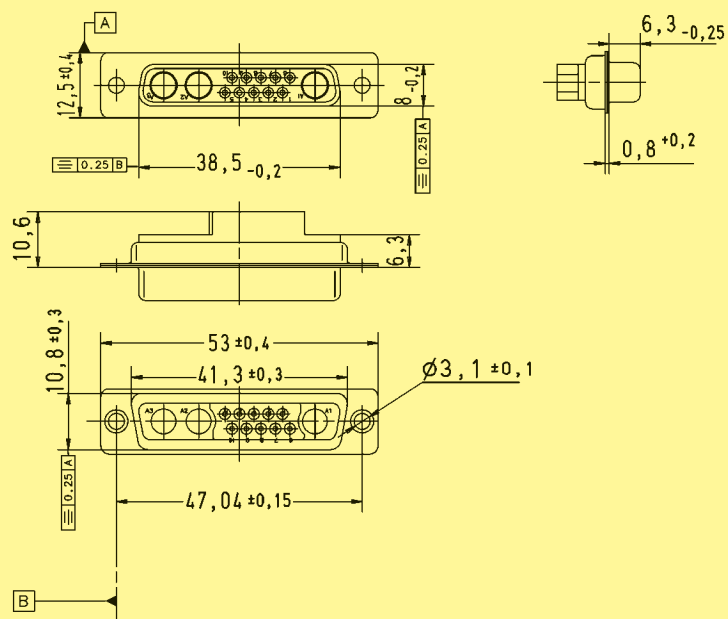

Dimensions in mm

D-Sub

<sup>1)</sup> Explanations see page 05.49  
 Board drillings see pages 05.76 ff  
 Order special contacts separately. See pages 05.67 ff

Number of contacts

# 11-21

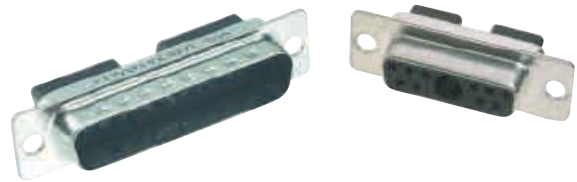

Mixed shells for signal crimp contacts

Identification	No. of contacts <sup>1)</sup>	Part No.
	11W1	male connectors 09 69 212 0111
		female connectors 09 69 202 0111
	21W1	male connectors 09 69 312 0211
		female connectors 09 69 302 0211

D-Sub

Male connectors

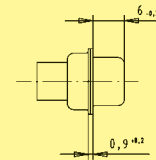
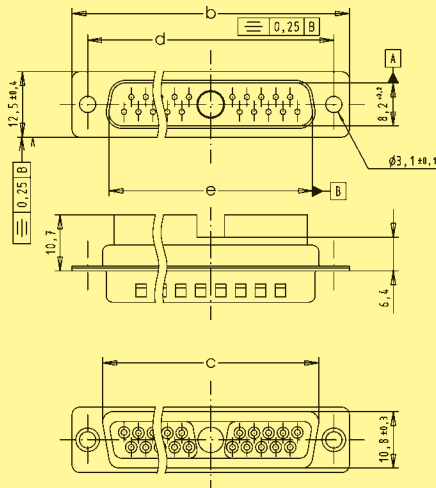

	a	b	c	d	e
11W1	24.7	39.1	27.5	33.30	25.2
21W1	38.5	53.0	41.3	47.04	38.9

Female connectors

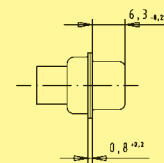
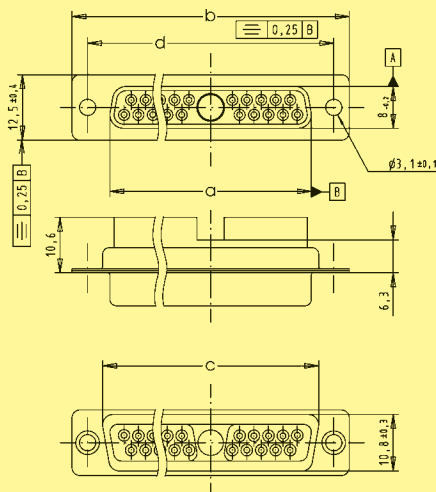

Dimensions in mm

<sup>1)</sup> Explanations see page 05.49  
 Order special contacts separately. See pages 05.67 ff  
 Board drillings see pages 05.76 ff

Number of contacts

# 36



Mixed shells for signal crimp contacts

Identification	No. of contacts <sup>1)</sup>	Part No.
		male connector
	36W4	09 69 512 0364
		female connector
		09 69 502 0364

### Male connectors

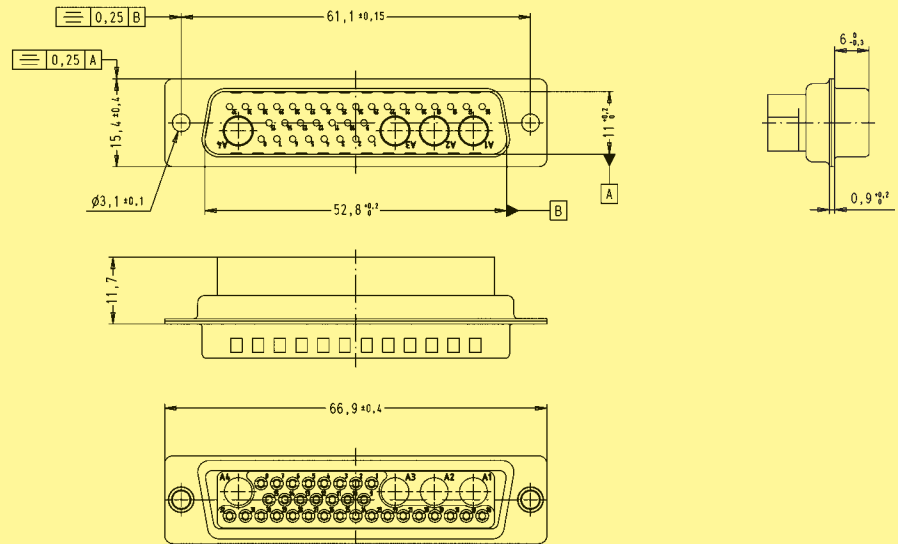

### Female connectors

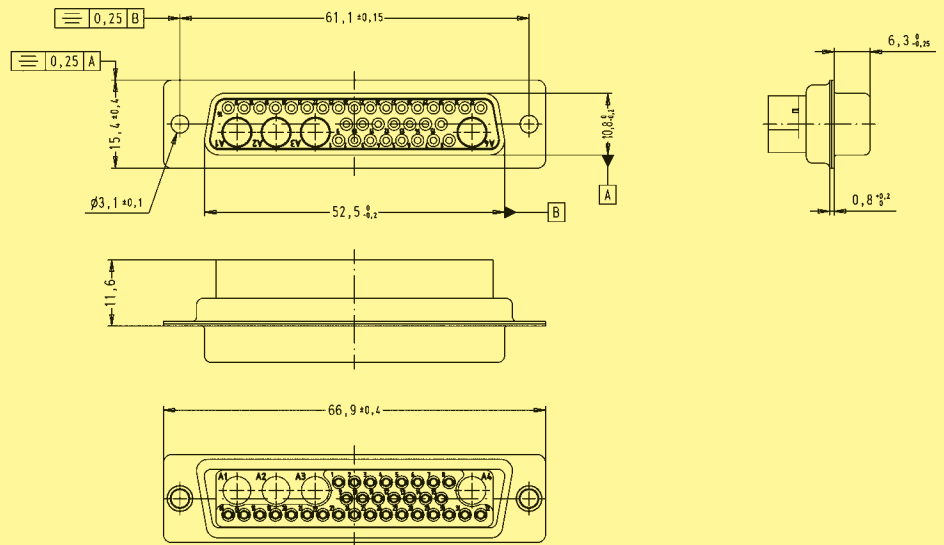

Dimensions in mm

<sup>1)</sup> Explanations see page 05.49  
 Board drillings see pages 05.76 ff  
 Order special contacts separately. See pages 05.67 ff

	Signal contacts see page 05.68	Coaxial contacts see pages 05.72 – 05.74	Power contacts see pages 05.70 + 05.71	High voltage contacts see page 05.69	Pneumatic contacts see page 05.75
Working current	5 A	2 A	10 A, 20 A, 30 A or 40 A	2 A DC	–
Test voltage $U_{r.m.s.}$	–	750 V / 50 Hz	–	4 kV / 50 Hz	–
Operating voltage	–	–	–	≤ 3 kV	–
Contact resistance	–	≤ 2.7 mΩ (inner and outer conductor)	≤ 1 mΩ	≤ 3 mΩ (outer conductor)	–
Impedance	–	50 / 75 Ω	–	–	–
Frequency range	–	0 - 2 GHz	–	–	–
Temperature range	–	-55 °C ... + 135 °C	-55 °C ... + 155 °C	-55 °C ... + 125 °C	-10 °C ... + 60 °C
Mating cycles					
high performance level	≥ 500	≥ 500	≥ 500	–	–
standard performance level	≥ 200	≥ 200	≥ 200	≥ 500	–
Mating force	≤ 3.4 N	≤ 7 N/mated pair	≤ 7 N/mated pair	≤ 5 N	–
Unmating force	≥ 0.2 N	≤ 7 N/mated pair	appr. 5 N	appr. 2.5 N	–
Max. pressure	–	–	–	–	7 bars at 20 °C
Materials					
Contacts	Copper alloy	Copper alloy	Copper alloy	Copper alloy	German silver
Plating*					
Mating side / terminating side	0.76 μm Au / 0.76 μm Au or 0.2 μm Au / 0.2 μm Au		0.76 μm Au / 0.2 μm Au or 0.2 μm Au / 5 μm Sn	1.3 μm Au / 1.3 μm Au	–
Inner conductor mating side / terminating side	–	1.3 μm Au / 1.3 μm Au or 0.2 μm Au / 0.2 μm Au	–	–	–
Outer conductor mating side / terminating side	–	0.76 μm Au / 0.2 μm Au or 0.2 μm Au / 5 μm Sn	–	–	–
Retaining clip	–	Copper alloy	Copper alloy	PI	–
Insulator	–	PBFE/PBTP/PI	–	PTFE	–
O-ring	–	–	–	–	Vitton



Straight signal crimp contacts for cable applications

Identification	Wire gauge (mm <sup>2</sup> )	Performance level	Part No.
Male contact	0.09 - 0.14 AWG 28 - 26	3	S4 <sup>1)</sup>
		09 69 282 7311	09 69 282 5311
Female contact	0.25 - 0.56 AWG 24 - 20	09 69 282 7310	09 69 282 5310
		09 69 182 7311	09 69 182 5311
Female contact	0.09 - 0.14 AWG 28 - 26	09 69 182 7310	09 69 182 5310
		09 69 182 7311	09 69 182 5311

Male contact

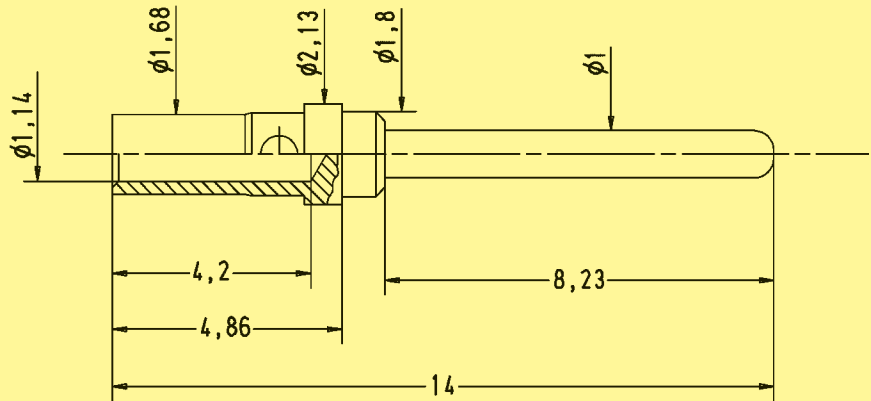

Female contact

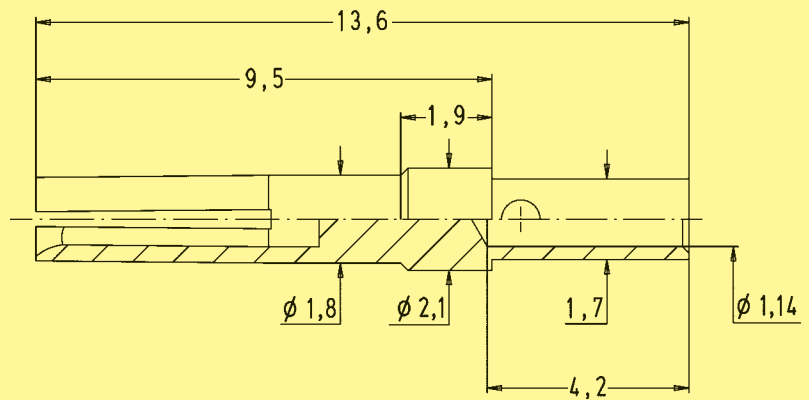

Dimensions in mm

<sup>1)</sup> S4: ≥ 0.76 μm Au  
Tooling see chapter 20



High voltage contacts for cable applications

Identification	Wire gauge (mm <sup>2</sup> )	Part No.	
Straight versions	0.25 - 0.56 AWG 24 - 20	Male contacts Plating: 1.3 µm Au <sup>1)</sup>	Female contacts Plating: 1.3 µm Au <sup>1)</sup>
		09 69 281 2550	09 69 181 2550
Right angled versions	0.25 - 0.56 AWG 24 - 20	09 69 681 2550	09 69 581 2550

D-Sub

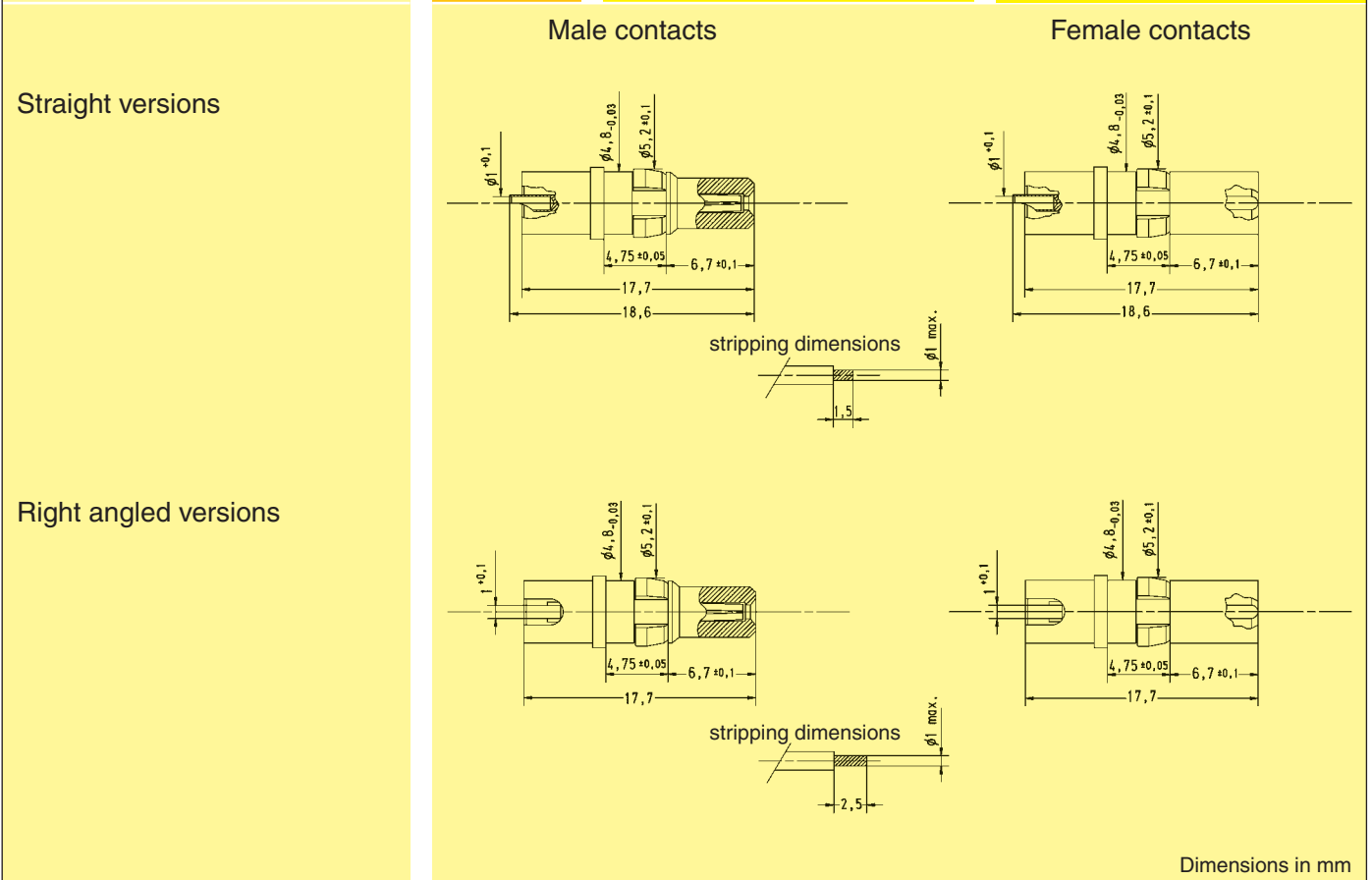

Dimensions in mm

<sup>1)</sup> for mating and terminating side

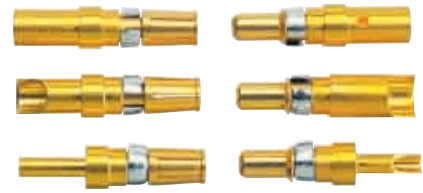

Straight power contacts for cable applications

Identification	Rating (A)	Part No.	
Performance levels		Performance level 3	S4 <sup>1)</sup>
<b>Solder version</b>			
<b>Male contacts</b>	10 20 30 40	09 69 281 7420 09 69 281 7421 09 69 281 7422 09 69 281 7423	09 69 281 5420 09 69 281 5421 09 69 281 5422 09 69 281 5423
<b>Short male contacts</b>	20 40	09 69 281 7821 09 69 281 7823	09 69 281 5821 09 69 281 5823
<b>Female contacts</b>	10 20 30 40	09 69 181 7420 09 69 181 7421 09 69 181 7422 09 69 181 7423	09 69 181 5420 09 69 181 5421 09 69 181 5422 09 69 181 5423
<b>Short female contacts</b>	20 40	09 69 181 7821 09 69 181 7823	09 69 181 5821 09 69 181 5823
<b>Crimp version<sup>2)</sup></b>			
<b>Male contacts</b>	10 20 30 40	09 69 282 7420 09 69 282 7421 09 69 282 7422 09 69 282 7423	09 69 282 5420 09 69 282 5421 09 69 282 5422 09 69 282 5423
<b>Short male contacts</b>	20 40	09 69 282 7821 09 69 282 7823	09 69 282 5821 09 69 282 5823
<b>Female contacts</b>	10 20 30 40	09 69 182 7420 09 69 182 7421 09 69 182 7422 09 69 182 7423	09 69 182 5420 09 69 182 5421 09 69 182 5422 09 69 182 5423
<b>Short female contacts</b>	20 40	09 69 182 7821 09 69 182 7823	09 69 182 5821 09 69 182 5823

D-Sub

<sup>1)</sup> S4: ≥ 0.76 μm Au  
<sup>2)</sup> Tooling see chapter 20

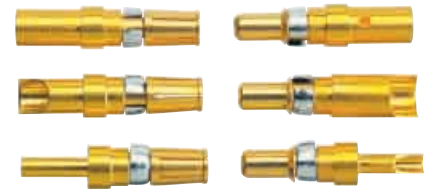

Straight power contacts for cable applications

Identification

Drawing

Dimensions in mm

Male contacts

solder

crimp

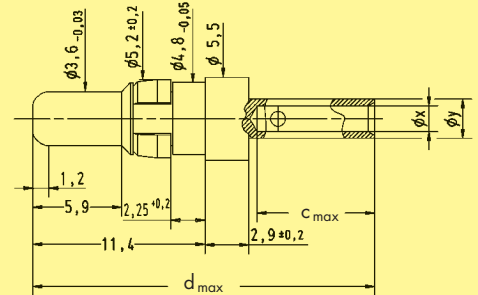
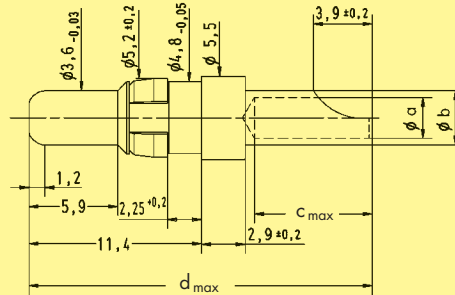

stripping dimensions

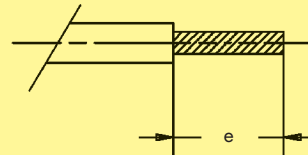

	Rating (A)	$\phi a -0.1$	$\phi b \pm 0.05$	$C_{max}$	$d_{max}$	e	$\phi x -0.1$	$\phi y \pm 0.05$	AWG
	10	1.8	2.54	7.8	23	7.5	1.7	2.6	16 - 20
	20	2.7	3.63	7.8	23	7.5	2.6	3.6	12 - 14
short version	20	2.7	3.63	4.7	19.2	4.5	2.6	3.6	12 - 14
	30	3.5	4.40	7.8	23	7.5	3.7	4.7	10 - 12
	40	4.8	5.50	7.8	23	7.5	4.6	5.8	8 - 10
short version	40	4.8	5.50	6.4	20	6.1	4.6	5.8	8 - 10

Female contacts

solder

crimp

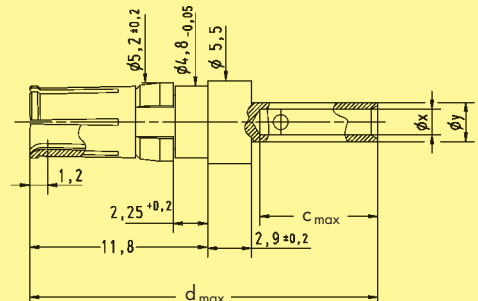
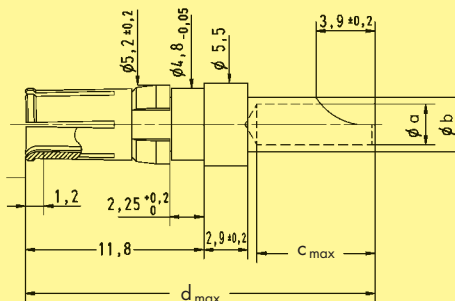

stripping dimensions

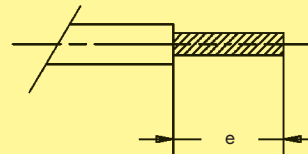





Coaxial contacts for cable applications

Identification	Impedance (Ω)	Part No.			
		Straight male contacts		Straight female contacts	
		Performance level 3	S4 <sup>1)</sup>	Performance level 3	S4 <sup>1)</sup>
<b>Solder / crimp contact</b>					
for cables RG 174 U, 188 AU, 316 U	50	09 69 281 7140	09 69 281 5140	09 69 181 7140	09 69 181 5140
for cables RG 178 BU, 196 AU, 404 U	50	09 69 281 7141	09 69 281 5141	09 69 181 7141	09 69 181 5141
for cables RG 58 CU, 141 AU	50	09 69 281 7143	09 69 281 5143	09 69 181 7143	09 69 181 5143
for cables RG 179 BU, 187 AU	75	09 69 281 7230	09 69 281 5230	09 69 181 7230	09 69 181 5230
for cables RGD 179	75	09 69 281 7233	09 69 281 5233	09 69 181 7233	09 69 181 5233
<b>Crimp / crimp contact</b>					
for cables RG 174 U, 188 AU, 316 U	50	09 69 282 7140	09 69 282 5140	09 69 182 7140	09 69 182 5140
for cables RG 179 BU, 187 AU	75	09 69 282 7230	09 69 282 5230	09 69 182 7230	09 69 182 5230
for cables RG 59	75	09 69 282 7232	09 69 282 5232	09 69 182 7232	09 69 182 5232
for cables RGD 179	75	09 69 282 7233	09 69 282 5233	09 69 182 7233	09 69 182 5233

Harnessing dimensions (mm)

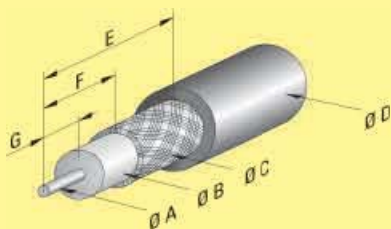

Part No.	Ø A	Ø B	Ø C	Ø D	E	F	G
09 69 181 x140 09 69 281 x140	0.85	1.9	2.3	3.2	9.5	5.0	3.0
09 69 181 x141 09 69 281 x141	0.85	1.2	1.4	2.3	9.5	5.0	3.0
09 69 181 x143 09 69 281 x143	1.00	3.0	4.4	5.2	9.5	5.0	3.0
09 69 181 x230 09 69 281 x230	0.50	1.9	2.3	3.2	9.5	5.0	3.0
09 69 182 x140 09 69 282 x140	0.60	1.9	2.4	3.2	9.0	5.0	3.0
09 69 182 x230 09 69 282 x230	0.60	1.9	2.4	3.2	9.0	5.0	3.0
09 69 182 x232 09 69 282 x232	0.95	3.8	5.1	6.2	9.0	4.3	3.7
09 69 181 x233 09 69 281 x233	0.50	1.9	2.6	3.5	9.5	5.0	3.0
09 69 182 x233 09 69 282 x233	0.60	1.9	2.6	3.5	9.3	4.3	3.0

<sup>1)</sup> S4: ≥ 0.76 µm Au  
Dimensions see pages 05.73 and 05.74  
Tooling see chapter 20



Coaxial contacts for cable applications

Identification

Drawing

Dimensions in mm

Male contacts

Part No.	ø a	ø b	ø c	ø d
09 69 281 x140	0.85	1.9	2.6	3.2
09 69 281 x141	0.85	1.2	1.7	2.3
09 69 281 x230	0.50	1.9	2.6	3.2

Part No.	ø a	ø b	ø c	ø d
09 69 281 x143	1.0	3.0	4.4	5.2

Part No.	ø a	ø b	ø c	ø d
09 69 281 x233	0.5	1.9	2.6	3.5

Part No.	ø a	ø b	ø c	ø d	ø e
09 69 282 x140	0.6	1.9	2.6	3.2	3.8
09 69 282 x230	0.6	1.9	2.6	3.2	3.8
09 69 282 x233	0.6	1.9	2.6	3.5	4.4

Part No.	ø a	ø b	ø c	ø d
09 69 282 x232	0.95	3.8	5.1	6.2

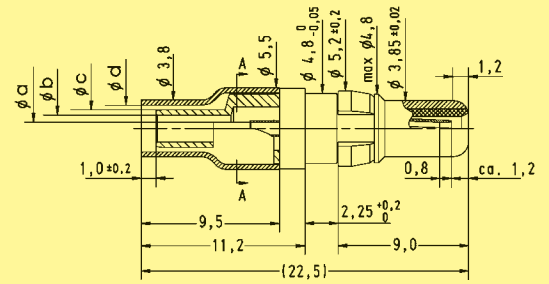

Points of plating thickness measurement

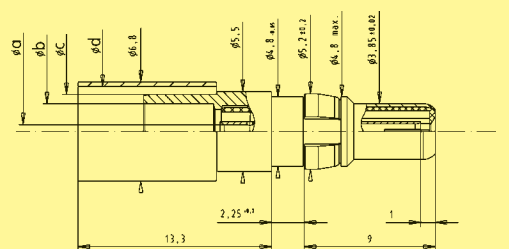
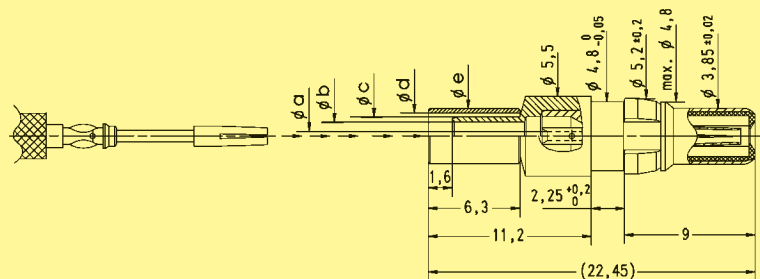
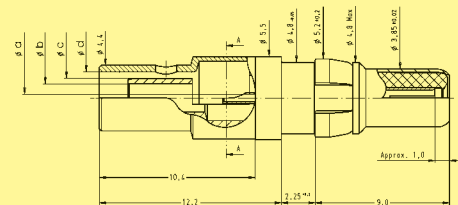
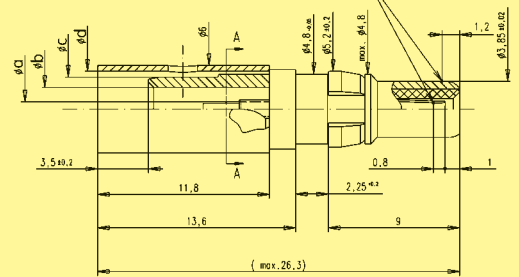



Coaxial contacts for cable applications

Identification

Drawing

Dimensions in mm

Female contacts

Part No.	ø a	ø b	ø c	ø d
09 69 181 x140	0.85	1.9	2.6	3.2
09 69 181 x141	0.85	1.2	1.7	2.3
09 69 181 x230	0.50	1.9	2.6	3.2

Part No.	ø a	ø b	ø c	ø d
09 69 181 x143	1.0	3.0	4.4	5.2

Part No.	ø a	ø b	ø c	ø d
09 69 181 x233	0.5	1.9	2.6	3.5

Part No.	ø a	ø b	ø c	ø d	ø e
09 69 182 x140	0.6	1.9	2.6	3.2	3.8
09 69 182 x230	0.6	1.9	2.6	3.2	3.8
09 69 182 x233	0.6	1.9	2.6	3.5	4.4

Part No.	ø a	ø b	ø c	ø d
09 69 182 x232	0.95	3.8	5.1	6.2

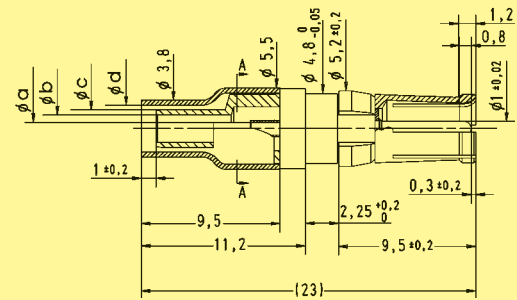

Points of plating thickness measurement

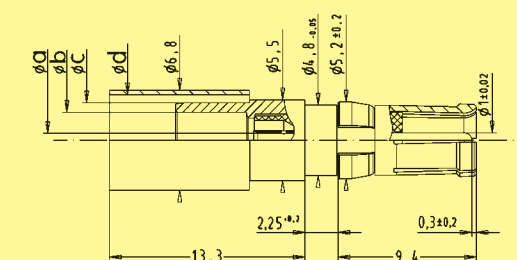
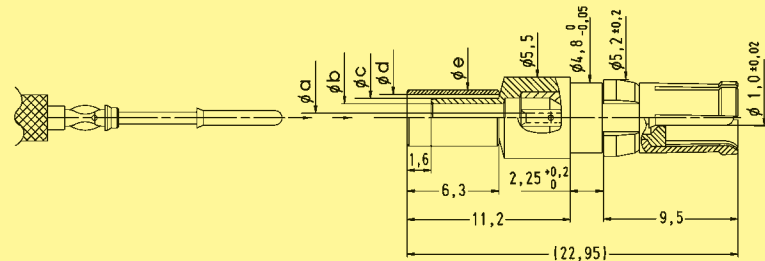
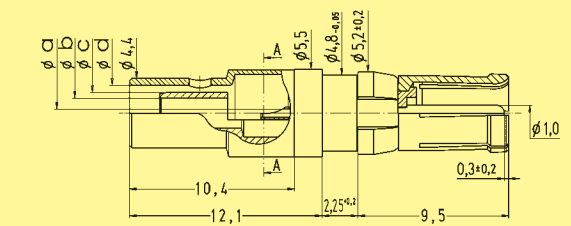
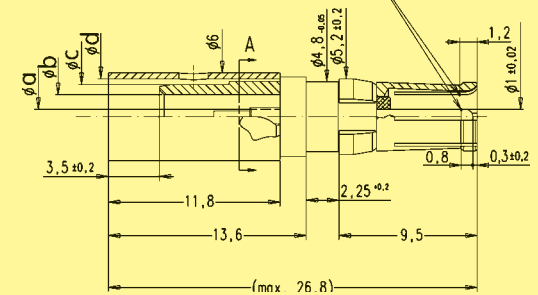

D-Sub



Pneumatic contacts for cable applications

Identification	Inner diameter air tube (mm)	Part No.
Male contacts	2	09 69 287 0060
	2.6	09 69 287 0061
	3	09 69 287 0062
	4	09 69 287 0063
Female contacts	2	09 69 187 0060
	2.6	09 69 187 0061
	3	09 69 187 0062
	4	09 69 187 0063

D-Sub

Male contacts

Female contacts

Part No.	ø a	ø b	ø c	ø d
09 69 x87 0060	1.45	2.6	1.5	0.95
09 69 x87 0061	1.65	3.1	2.0	1.65
09 69 x87 0062	1.65	3.4	2.3	1.85
09 69 x87 0063	1.65	4.8	3.7	2.95

Dimensions in mm

Board drillings for connectors with straight pcb contacts

Pcb hole patterns

In the next pages, the pcb hole pattern is given for the power and the coaxial contact per connector layout. In the case of the power contact, the drilling hole dimension is not mentioned; the table here under provides relevant information according to the current rating of the contact and its version.

Power contact diameter and pcb related drilling diameter

Rating	Straight connectors		Right angled connectors	
	Pin Ø (mm)	Pcb drilling Ø (mm)	Pin Ø (mm)	Pcb drilling Ø (mm)
20 A	2.60	2.9	2.85	3.15
30 A	—	—	3.20	3.50
40 A	3.75	4.0	3.75	4.05

Identification Drawing Dimensions in mm

Male connector\*

Power contact

Coaxial contact

2W2C

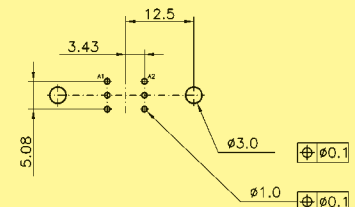
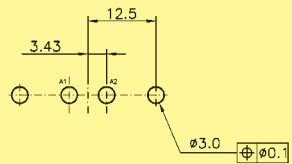

3W3 / 3W3C

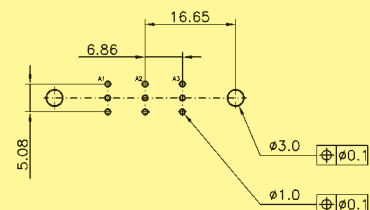
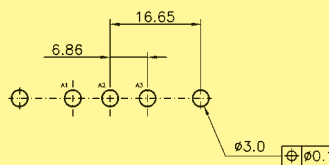

5W1

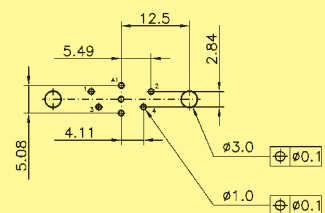
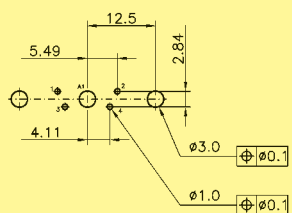

5W5

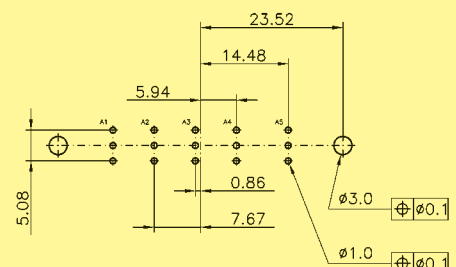
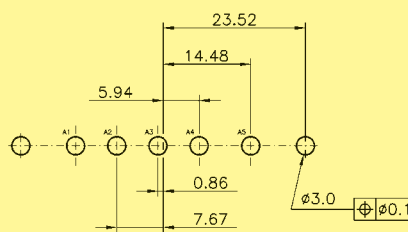

7W2

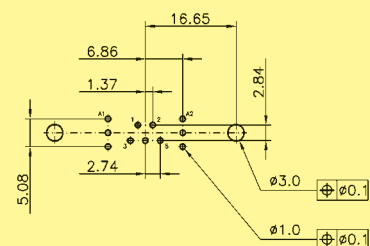
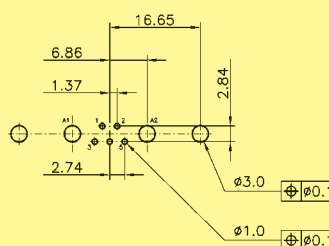

\* When using a female connector with straight pcb contacts the board drilling pattern must be mirrored in the Y axis.



Board drillings for connectors with straight pcb contacts

Identification

Drawing

Dimensions in mm

Male connector\*

Power contact

Coaxial contact

7W7

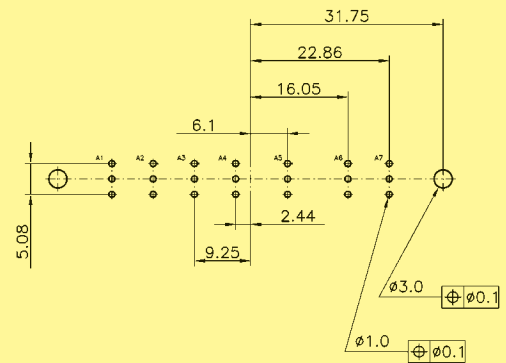
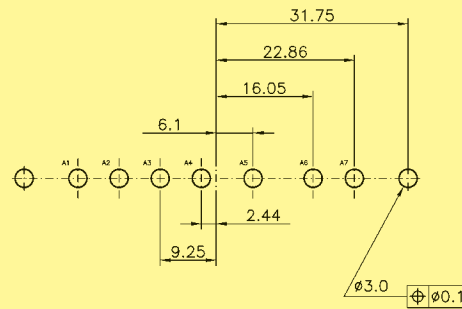

8W8

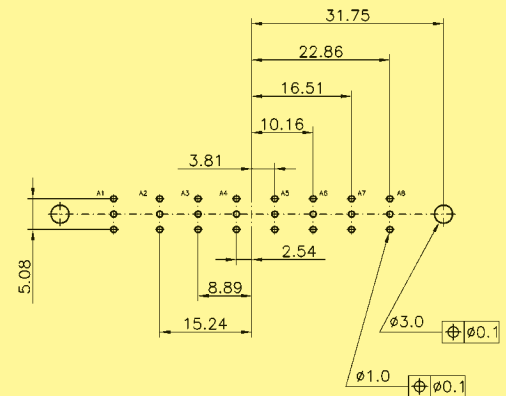
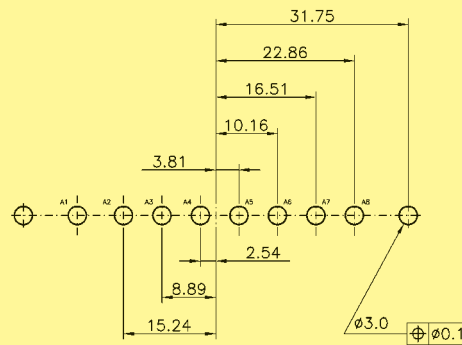

9W4

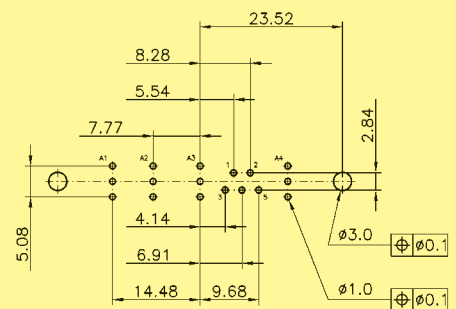
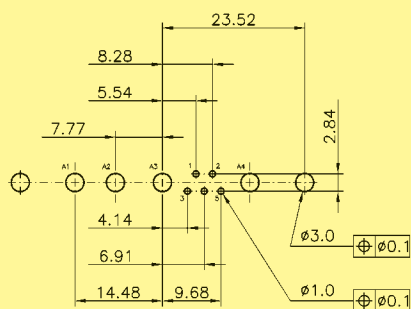

11W1

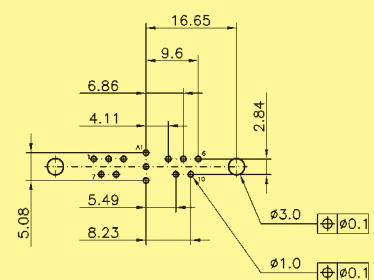
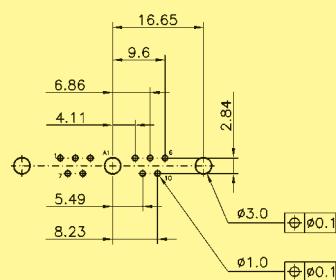

D-Sub

\* When using a female connector with straight pcb contacts the board drilling pattern must be mirrored in the Y axis.



Board drillings for connectors with straight pcb contacts

Identification Drawing Dimensions in mm

Male connector\*

13W3

Power contact

Coaxial contact

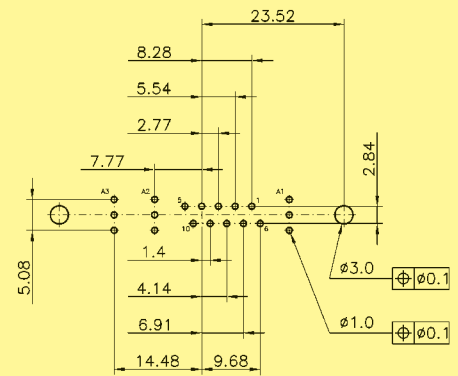
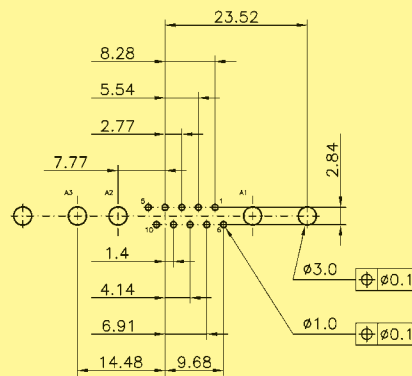

13W6

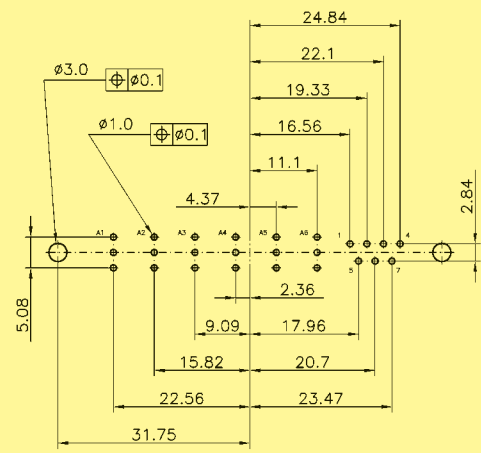
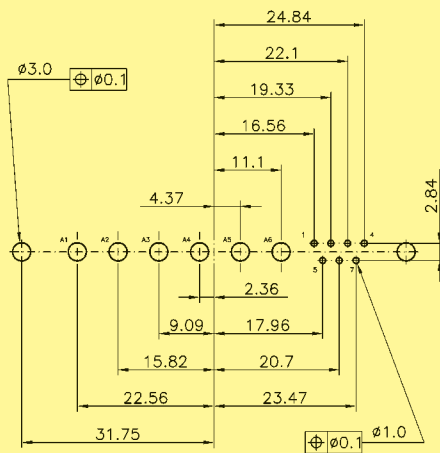

17W2

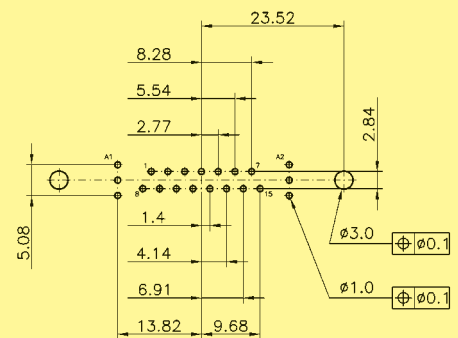
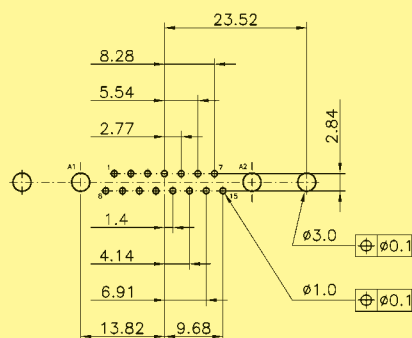

D-Sub

\* When using a female connector with straight pcb contacts the board drilling pattern must be mirrored in the Y axis.



Board drillings for connectors with straight pcb contacts

Identification

Drawing

Dimensions in mm

Male connector\*

21W1

Power contact

Coaxial contact

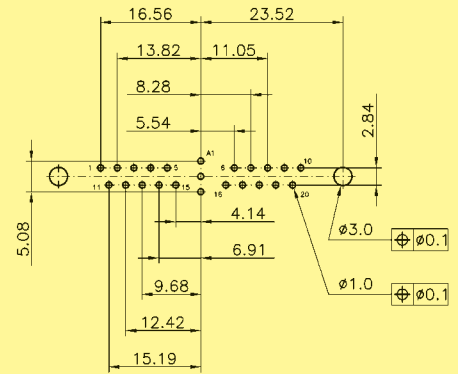
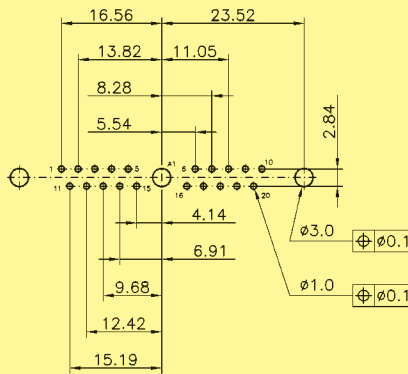

21WA4

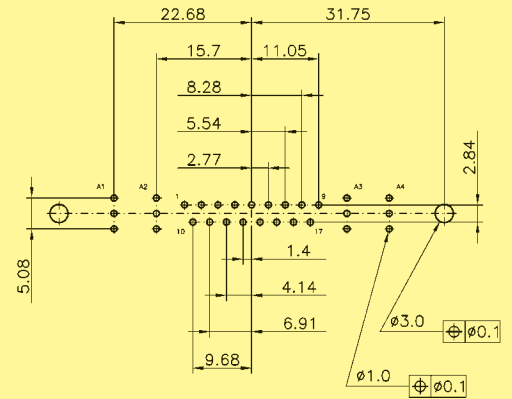
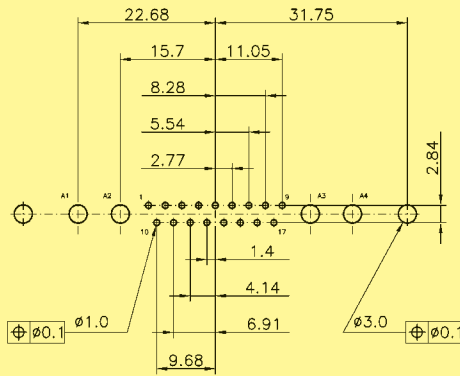

24W7

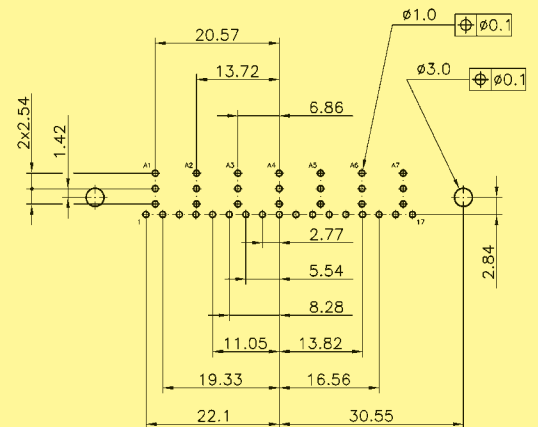
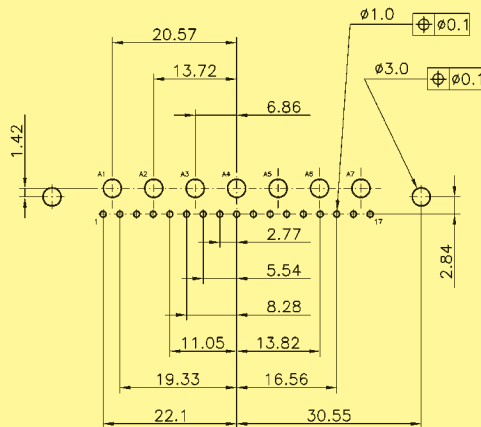

D-Sub

\* When using a female connector with straight pcb contacts the board drilling pattern must be mirrored in the Y axis.





Board drillings for connectors with straight pcb contacts

Identification Drawing Dimensions in mm

Male connector\*

25W3

Power contact

Coaxial contact

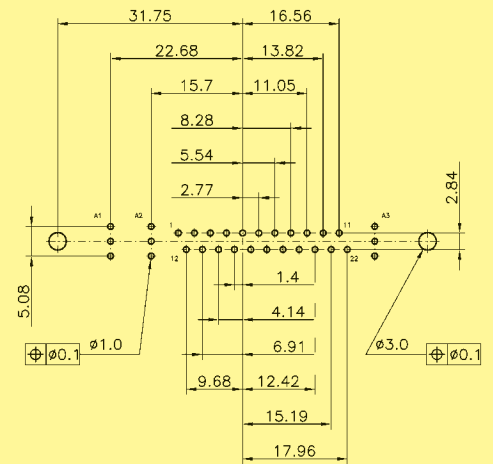
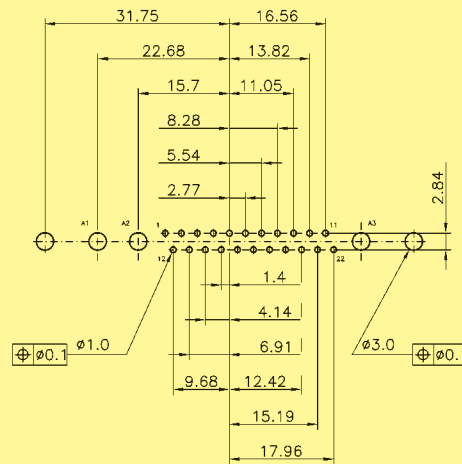

27W2

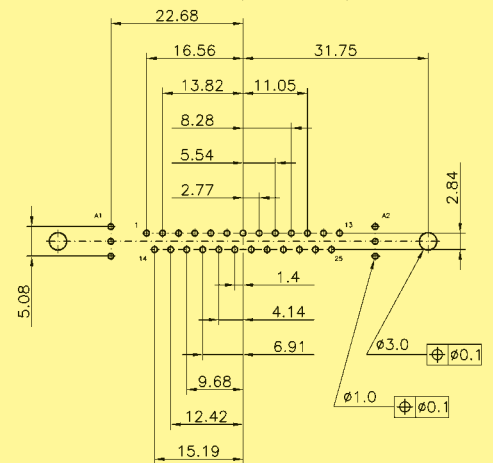
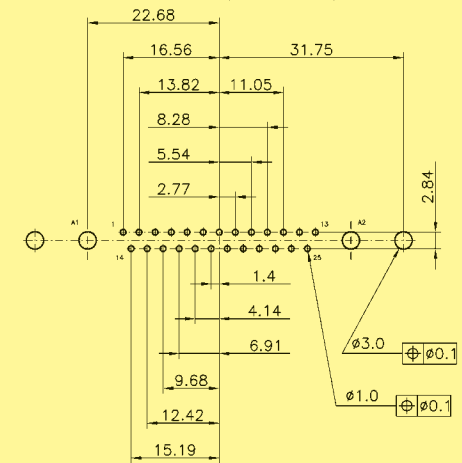

36W4

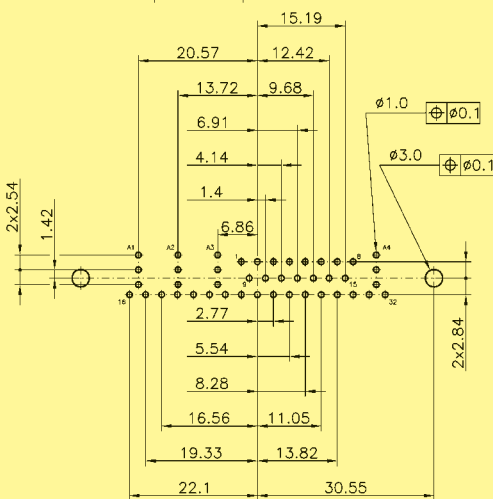
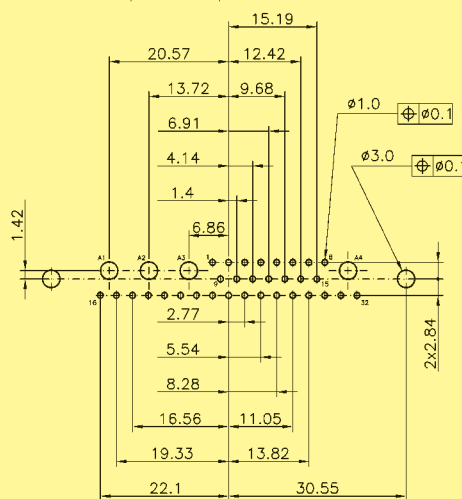

D-Sub

\* When using a female connector with straight pcb contacts the board drilling pattern must be mirrored in the Y axis.

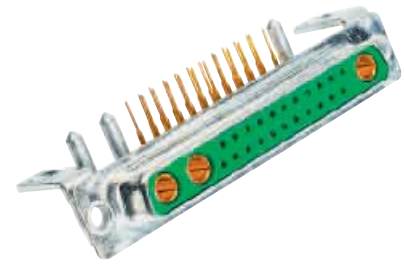

Board drillings for connectors with right angled pcb contacts

Identification      Drawing      Dimensions in mm

Male connector\*

2W2C

Power contact

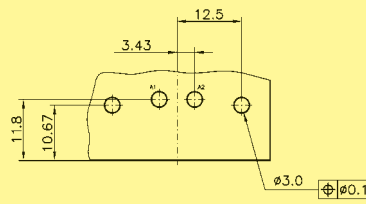

Coaxial contact

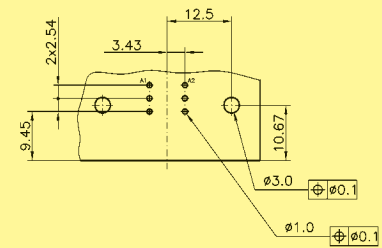

3W3 / 3W3C

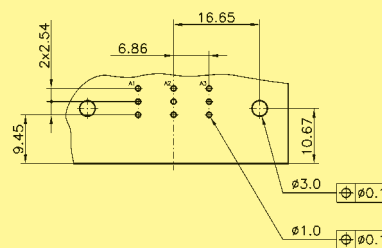
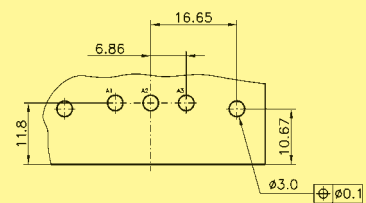

5W1

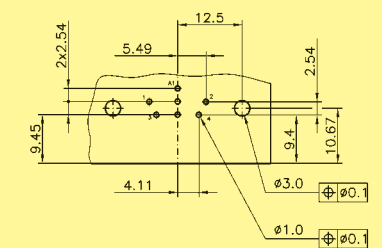
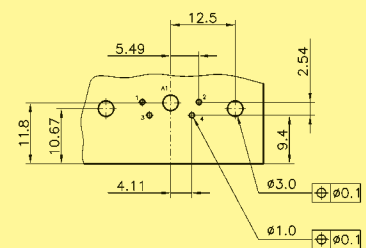

5W5

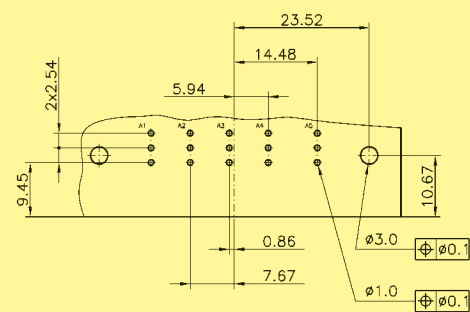
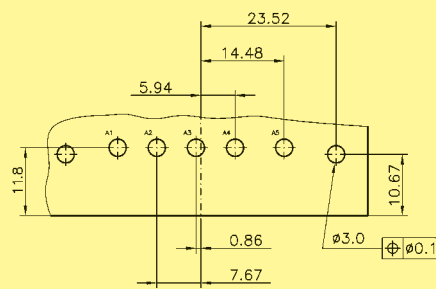

7W2

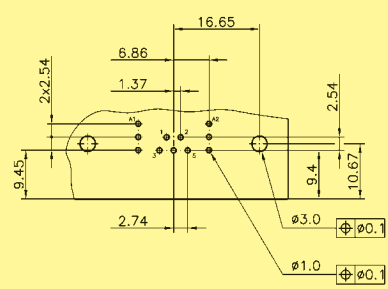
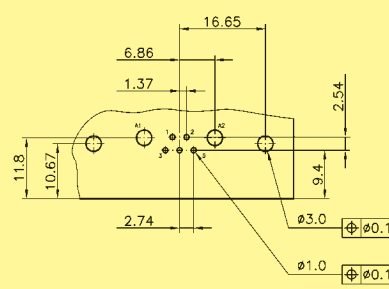

D-Sub

\* When using a female connector with right angled pcb contacts the board drilling pattern must be mirrored in the Y axis.

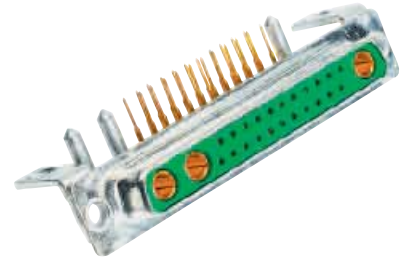

Board drillings for connectors with right angled pcb contacts

Identification Drawing Dimensions in mm

Male connector\*

7W7

Power contact

Coaxial contact

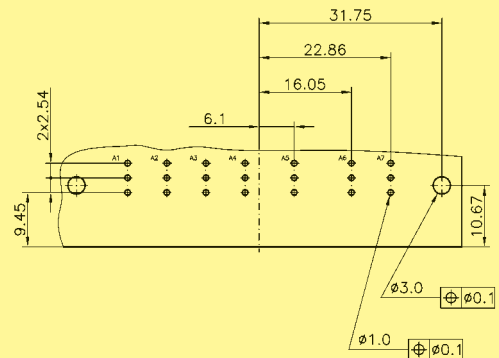
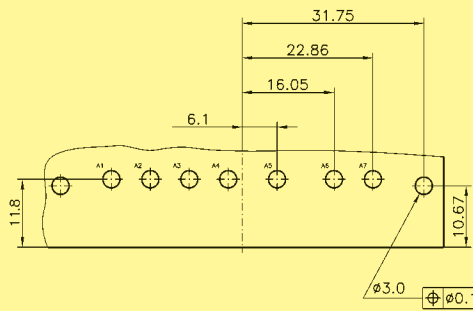

8W8

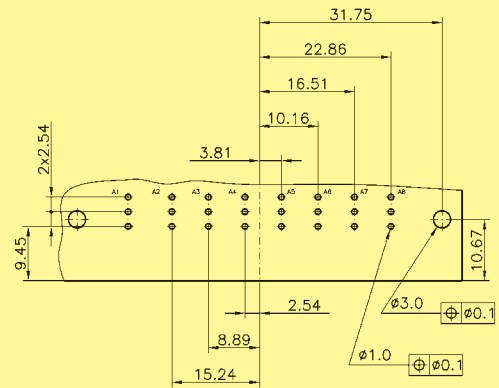
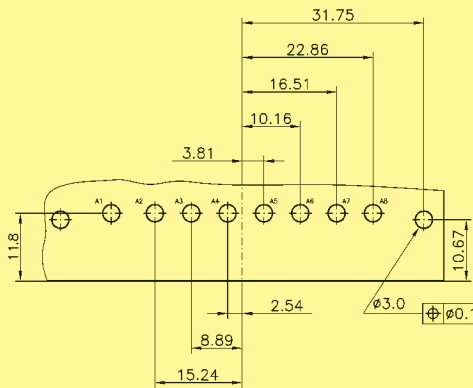

9W4

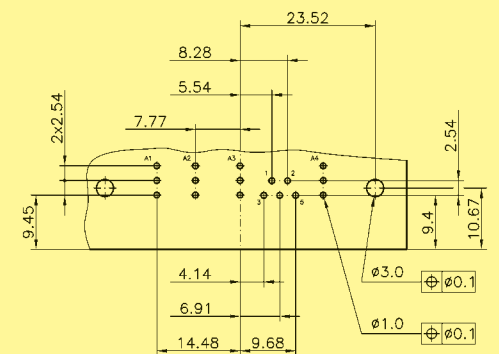
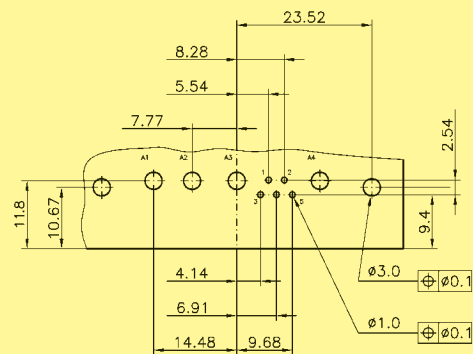

11W1

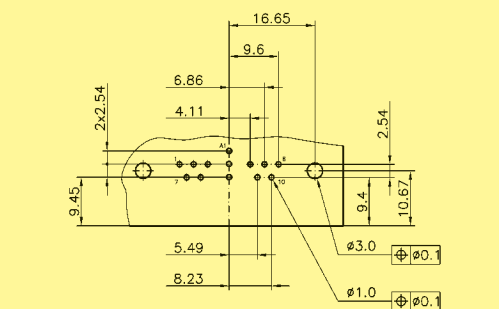
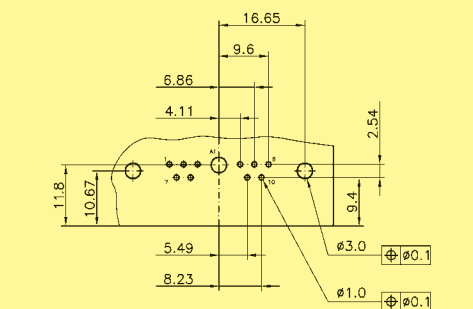

D-Sub

\* When using a female connector with right angled pcb contacts the board drilling pattern must be mirrored in the Y axis.

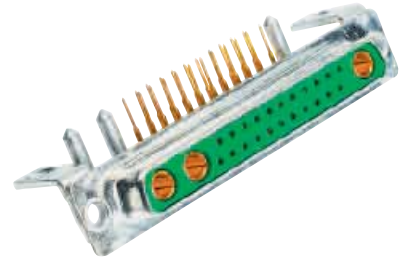

Board drillings for connectors with right angled pcb contacts

Identification

Drawing

Dimensions in mm

Male connector\*

13W3

Power contact

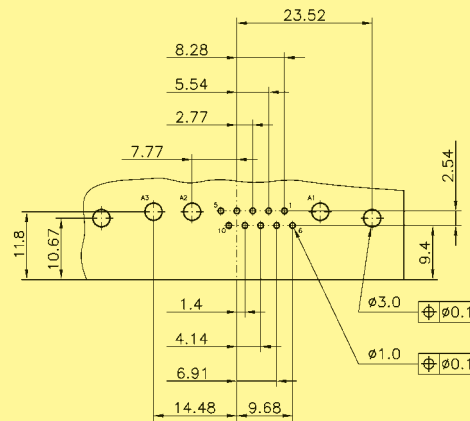

Coaxial contact

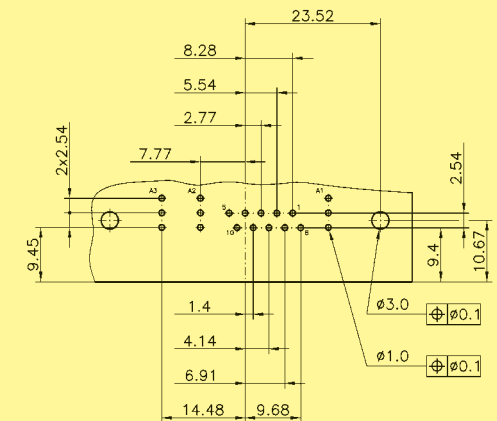

13W6

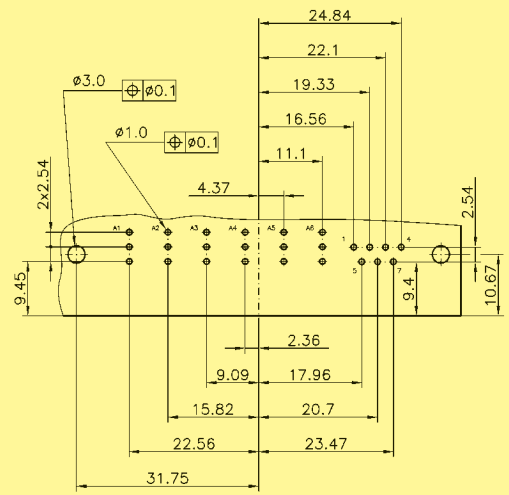
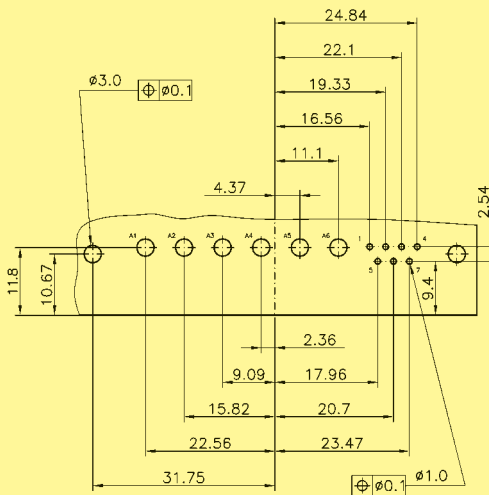

17W2

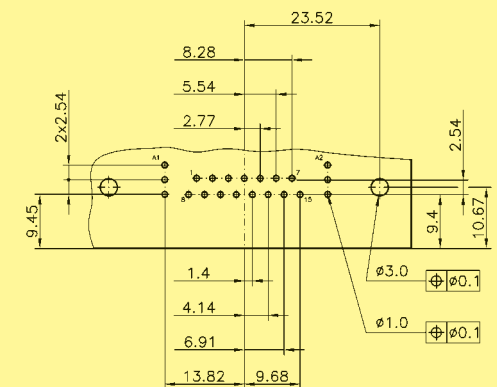
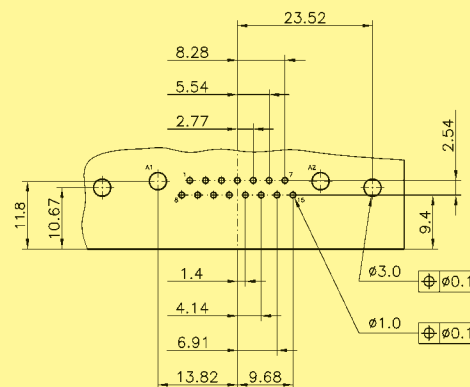

D-Sub

\* When using a female connector with right angled pcb contacts the board drilling pattern must be mirrored in the Y axis.

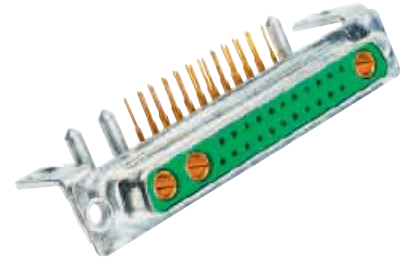

Board drillings for connectors with right angled pcb contacts

Identification

Drawing

Dimensions in mm

Male connector\*

21W1

Power contact

Coaxial contact

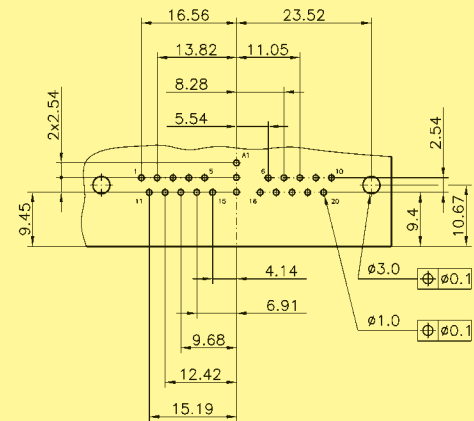
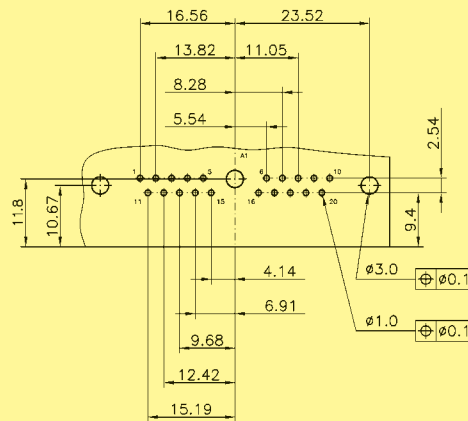

21WA4

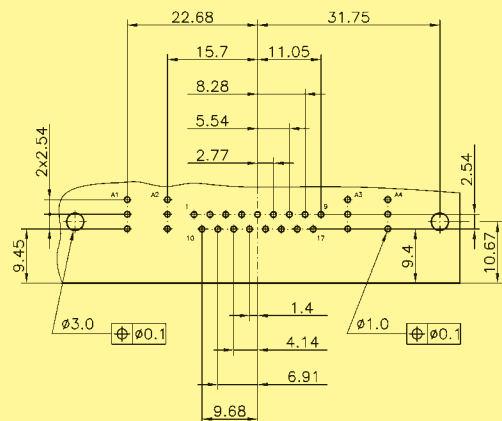
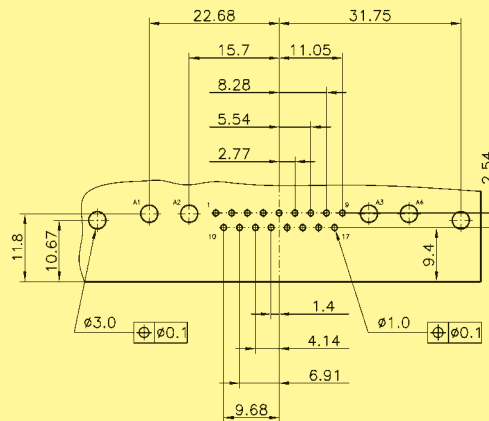

24W7

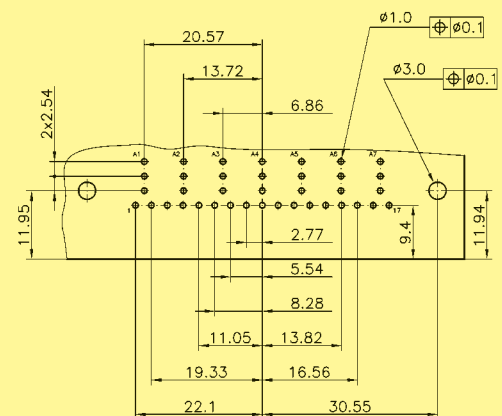
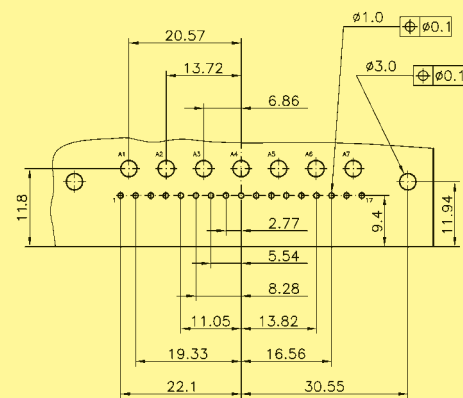

\* When using a female connector with right angled pcb contacts the board drilling pattern must be mirrored in the Y axis.

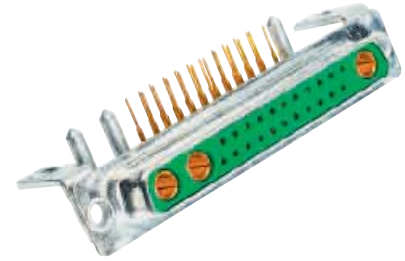

Board drillings for connectors with right angled pcb contacts

Identification

Drawing

Dimensions in mm

Male connector\*

25W3

Power contact

Coaxial contact

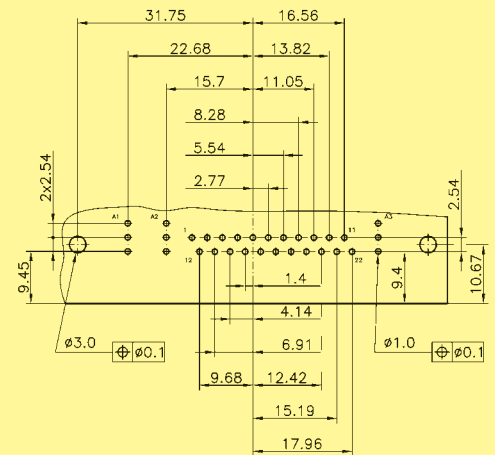
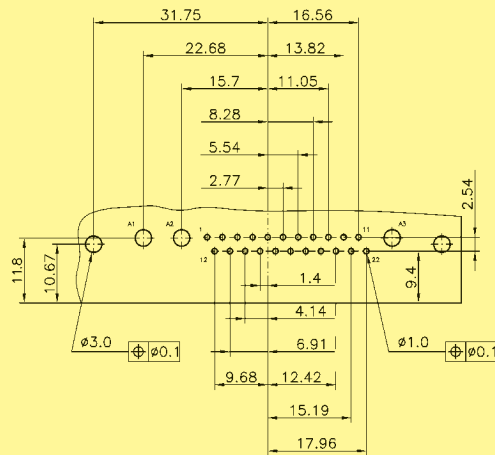

27W2

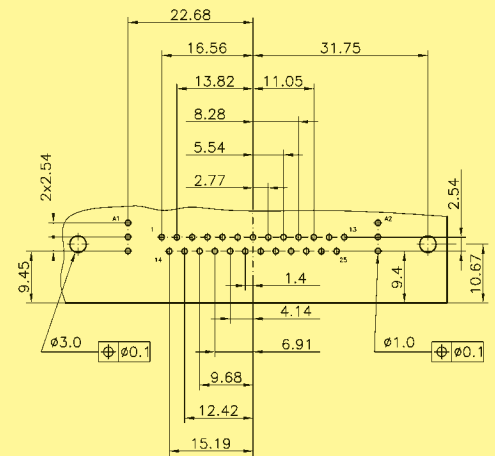
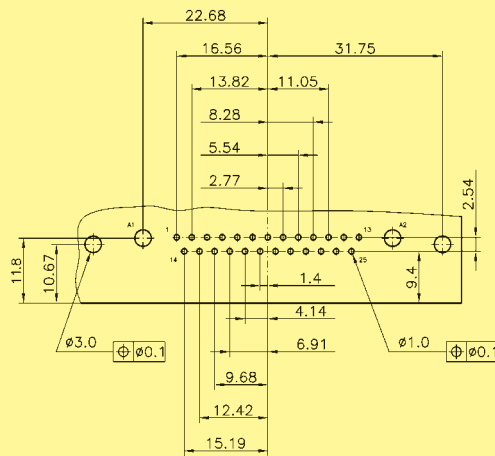

36W4

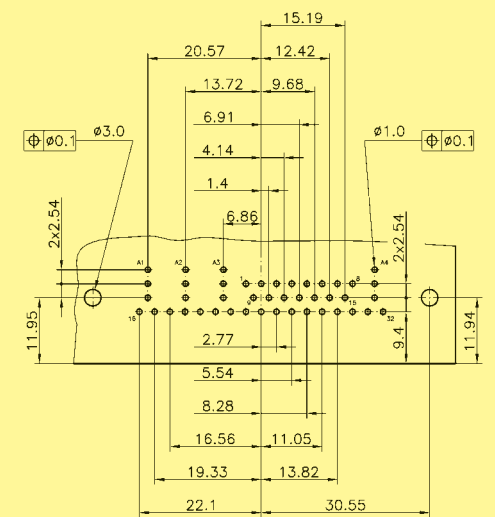
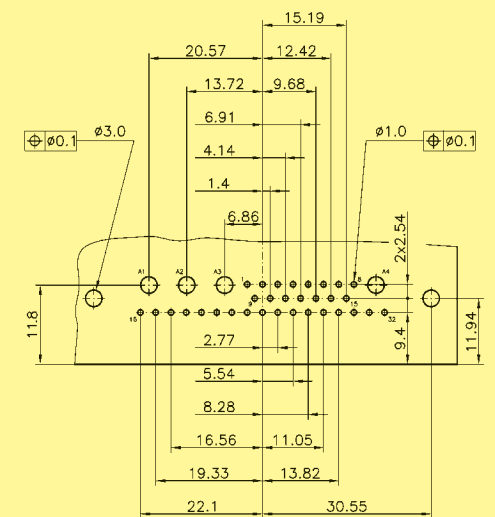

D-Sub

\* When using a female connector with right angled pcb contacts the board drilling pattern must be mirrored in the Y axis.

## HARTING customer request form for pcb connectors

### 1 Connector gender and type

- Plug (male contacts)  
 Receptacle (female contacts)

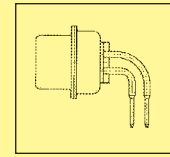
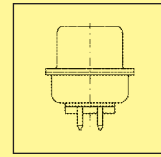

- Straight       Right angled

### 2 Contact arrangement

Standard

- |                              |                               |                                |                               |
|------------------------------|-------------------------------|--------------------------------|-------------------------------|
| <input type="checkbox"/> 3W3 | <input type="checkbox"/> 8W8  | <input type="checkbox"/> 17W2  |                               |
| <input type="checkbox"/> 5W1 | <input type="checkbox"/> 9W4  | <input type="checkbox"/> 21W1  |                               |
| <input type="checkbox"/> 5W5 | <input type="checkbox"/> 11W1 | <input type="checkbox"/> 21WA4 |                               |
| <input type="checkbox"/> 7W2 | <input type="checkbox"/> 13W3 | <input type="checkbox"/> 24W7  | <input type="checkbox"/> 27W2 |
| <input type="checkbox"/> 7W7 | <input type="checkbox"/> 13W6 | <input type="checkbox"/> 25W3  | <input type="checkbox"/> 36W4 |

Special configurations  
(mixed contact genders)

- 2W2C       3W3C

#### 2.1 Any signal contacts?

- Yes (fill in questions below)     No (go directly to item 2.2)
- Right angled 2.54 mm pitch  
 Other pitch: \_\_\_\_\_

#### 2.2 Any power contacts?

Current rating

- Yes (fill in questions below)     No (go directly to item 2.3)
- 10 A       30 A  
 20 A       40 A

Termination type

- Solder pin for pcb  
 Press-in for pcb (30A)

Performance level  
[mating side / termination side]

- S4 [0.76 µm Au / 0.2 µm Au]  
 PL 3 [0.2 µm Au / 5.0 µm Sn]

#### 2.3 Any coaxial contacts?

Impedance

- Yes (fill in questions below)     No (go directly to item 2.4)
- 50 Ω  
 75 Ω

Performance level  
[mating side inner / outer conductor]

- S4 [1.3 µm Au / 0.76 µm Au]  
 PL 3 [0.2 µm Au / 0.2 µm Au]

#### 2.4 Any high voltage contacts?

- Yes       No (go directly to item 2.5)

#### 2.5 Any pneumatic contacts?

Tube inner diameter /  
suitable compressed air tube

- Yes (fill in questions below)     No (go directly to item 3)
- 2 mm / PU-2       2.6 mm / PU-N4\* 2.5  
 3 mm / PU-3       4 mm / PU-4

## HARTING customer request form for pcb connectors

### 3 Pcb mounting accessories (select appropriate fixing accessories)

#### 3.1 Right angled version

- Through hole
  - Nut 4-40 UNC
  - Nut M3
  - Metal bracket
  - Snap clip
  - Screw lock
    - fixed       removable
    - 4-40 UNC     M3
- 

#### 3.2 Straight version

- Through hole
  - Nut 4-40 UNC
  - Nut M3
  - Spacer 4-40 UNC
  - Spacer M3
  - Screw lock 4-40 UNC
  - Spacer 4-40 UNC + clip
  - Spacer M3 + clip
  - Spacer + clip and screw lock
    - M3       4-40 UNC
- 

### 4 Additional information

Pcb thickness:

*(if possible provide pcb layout with plating specifications)*

Operating temperature:

- standard
- SMC compatible

Is hot plugging required

- No
- Yes

Short description: \_\_\_\_\_

Is a vacuum pick and place process considered?

- No
- Yes

Is blind mating feature required?

- No
- Yes (provide precise requirements)

Name: \_\_\_\_\_

Drawing:  no       yes

Company: \_\_\_\_\_

Samples:  no       yes, quantity

Address: \_\_\_\_\_

Volume (pcs./year): \_\_\_\_\_

Phone: \_\_\_\_\_

Special requirements: \_\_\_\_\_

Fax: \_\_\_\_\_

E-Mail: \_\_\_\_\_



## HARTING customer request form for cable connectors

### 1 Connector gender

- Plug (male contacts)  
 Receptacle (female contacts)



21W4 mixed male for cable

### 2 Contact arrangement

Standard

- |                              |                               |                                |                               |
|------------------------------|-------------------------------|--------------------------------|-------------------------------|
| <input type="checkbox"/> 3W3 | <input type="checkbox"/> 8W8  | <input type="checkbox"/> 17W2  |                               |
| <input type="checkbox"/> 5W1 | <input type="checkbox"/> 9W4  | <input type="checkbox"/> 21W1  |                               |
| <input type="checkbox"/> 5W5 | <input type="checkbox"/> 11W1 | <input type="checkbox"/> 21WA4 |                               |
| <input type="checkbox"/> 7W2 | <input type="checkbox"/> 13W3 | <input type="checkbox"/> 24W7  | <input type="checkbox"/> 27W2 |
| <input type="checkbox"/> 7W7 | <input type="checkbox"/> 13W6 | <input type="checkbox"/> 25W3  | <input type="checkbox"/> 36W4 |

Special configurations  
(mixed contact genders)

- 2W2C  3W3C

#### 2.1 Any signal contacts?

- Yes (fill in questions below)  No (go directly to item 2.2)

Termination type

- Crimp  Solder cup S4 [0.76 µm Au]

Signal cable size for crimp contact

- AWG 20-24  AWG 26-28

Crimp contact performance level

- S4 [0.76 µm Au / 0.2 µm Au]  
 PL3 [0.2 µm Au / 5.0 µm Sn]

#### 2.2 Any power contacts?

- Yes (fill in questions below)  No (go directly to item 2.3)

Current rating

- 10 A  20 A  30 A  40 A

Termination type

- Crimp  Solder cup

Performance level

[mating side / termination side]

- S4 [0.76 µm Au / 0.2 µm Au]  
 PL3 [0.2 µm Au / 5.0 µm Sn]

#### 2.3 Any coaxial contacts?

- Yes (fill in questions below)  No (go directly to item 2.4)

Impedance

- 50 Ω  75 Ω

Termination type

- Crimp/crimp  
 Crimp/solder [inner conductor is soldered, outer crimped]

Performance level

[mating side inner / outer conductor]

- S4 [1.3 µm Au / 0.76 µm Au]  
 PL3 [0.2 µm Au / 0.2 µm Au]

Cable reference (e.g. RG 178): \_\_\_\_\_

## HARTING customer request form for cable connectors

**2.4 Any high voltage contacts?**  Yes  No (go directly to item 2.5)

**2.5 Any pneumatic contacts?**  Yes (fill in questions below)  No (go directly to item 3)

Tube inner diameter /  
suitable compressed air tube

2 mm / PU-2  
 3 mm / PU-3

2.6 mm / PU-N4\* 2.5  
 4 mm / PU-4

### 3 Cable accessories

HARTING has a wide range of hoods including plastic, metallized plastic and full metal versions.

Name: \_\_\_\_\_

Drawing:  no  yes \_\_\_\_\_

Company: \_\_\_\_\_

Samples:  no  yes, quantity \_\_\_\_\_

Address: \_\_\_\_\_

Volume (pcs./year): \_\_\_\_\_

\_\_\_\_\_

\_\_\_\_\_

Phone: \_\_\_\_\_

Special requirements: \_\_\_\_\_

Fax: \_\_\_\_\_

\_\_\_\_\_

E-Mail: \_\_\_\_\_

\_\_\_\_\_

HARTING filter D connectors are distinguished by their high performance and offer optimal filtering. The filtering element incorporates a multi-layer printed circuit board and surface mount components, all within the standard D-Sub shell.

The HARTING filter D range consists of:

- A standard range of products (available from stock for pcb and cable applications):
  - male and female connectors
  - various terminations such as solder buckets, straight and right angled solder pins
  - 9, 15, 25 and 37 contact versions
  - a large range of accessories

• **Customized solutions:**

The innovative technical solution of filtering enables customers to select the optimum filter on a contact by contact approach. This flexible technology allows not only to segregate the filtering per contact but also to mix the type of filter in a single competitive product. Please contact your local HARTING representative. Customized possibilities are explained on pages 05.120 ff.

HARTING filtered D connectors are suitable for military, aerospace, industrial, medical, telecom and computers applications.

HARTING filter D connectors can also take advantage of **reflow soldering** and the cost savings it brings.

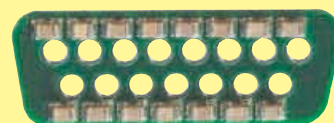
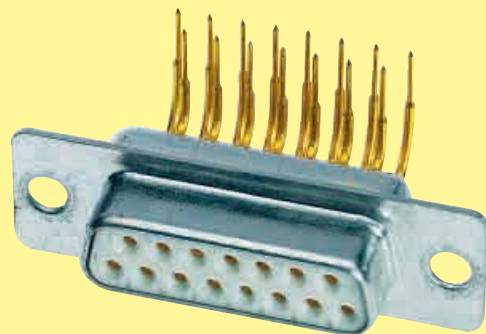
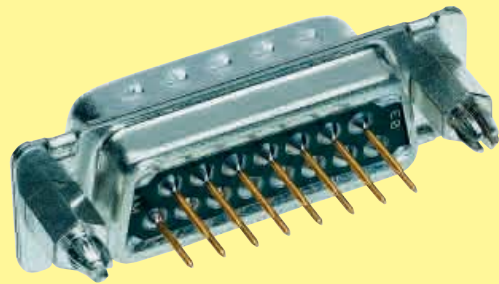

Number of contacts	9, 15, 25, 37
Working current	7.5 A max. (connectors) 6.5 A max. (filter adapters)
Working voltage	100 V max. for standard capacitance values – higher working voltages are available as specific.
Dielectric withstanding voltage	250 V DC max. – higher dielectric withstanding voltages are available as specific (see page 05.118)
Contact resistance Insulation resistance	≤ 10 mΩ ≥ 1000 MΩ
Temperature range	-55 °C ... + 125 °C (connectors) Heat deflection temperature limit according to DIN 53 461: ... + 255 °C  -20 °C ... + 125 °C (filter adapters)
Terminations	a) Solder buckets max. 0.8 mm <sup>2</sup> b) Solder pins Ø 0.6 mm for P.C.B. holes Ø 0.8/1 mm c) Solder pins, angled 90° Ø 0.6 mm for P.C.B. holes Ø 0.8/1 mm
Materials Insulation	PCT, glass-fibre filled, flame retardant acc. to UL 94-V0 Colour: natural
Contacts	Copper alloy Male and female contacts are turned
Contact surface Contact zone	Selectively plated according to performance level
Performance level	Performance level 2, as per CECC 75 301-802, 250 mating cycles, 4 days 4 mixed gas test – IEC 60 512
Metal shell	Steel

Contact arrangement  
View from termination side

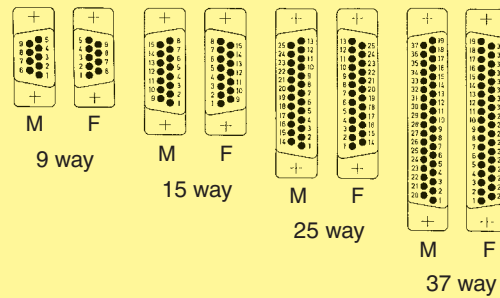

M = Male connector  
F = Female connector

Mating conditions as per CECC 75 301

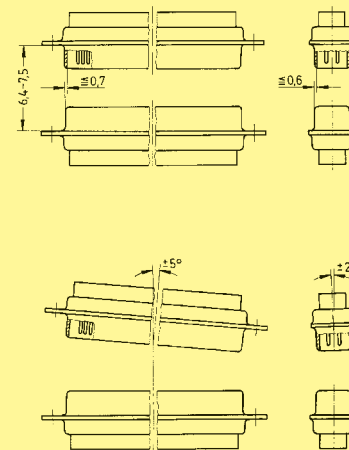

Attenuation characteristics for standard capacitance values

Min. insertion loss

		Attenuation (in dB) vs. frequency [MHz]						
Capacitance [pF] <sup>1)</sup>	Frequency [MHz]	1	5	10	50	100	500	1000
	47							30
470				1	11	16	35	32
1000			1	3	12	24	38	30
3900		1	6	11	25	35	38	32

<sup>1)</sup> Capacitance tolerance = ± 20 % (For other capacitor values see pages 05.118 ff).

Measured in 50 Ω system according to MIL-STD-220, no load.

**Working voltage:** 100 V max. for standard capacitance values – higher working voltages are available as specific.

**Dielectric withstanding voltage:** 250 V DC max. – higher dielectric withstanding voltages are available as specific (see page 05.118)

Typical insertion loss for different filters (measured)

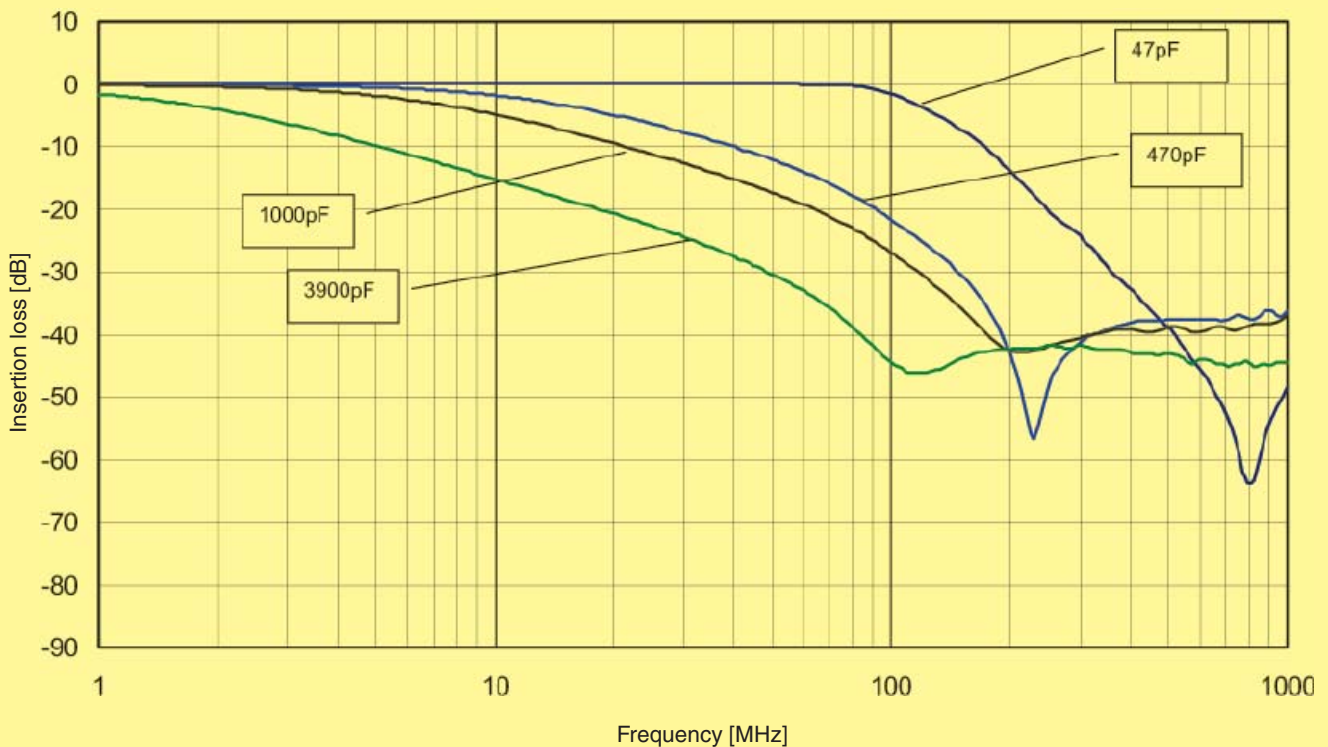

Number of contacts

# 9-37



## Filter adapters

Identification	No. of contacts	Part No.
Male / female filter adapters with C filter	9	09 64 100 72 ..
	15	09 64 200 72 ..
	25	09 64 300 72 ..
	37	09 64 400 72 ..
Please insert digit for capacitance	47 pF ▶ 10	
	470 pF ▶ 20	
	1000 pF ▶ 30	
	3900 pF ▶ 40	

D-Sub

## Dimensions

	A	B
9	32.8	24.99
15	41.1	33.32
25	55.0	47.04
37	71.3	63.50

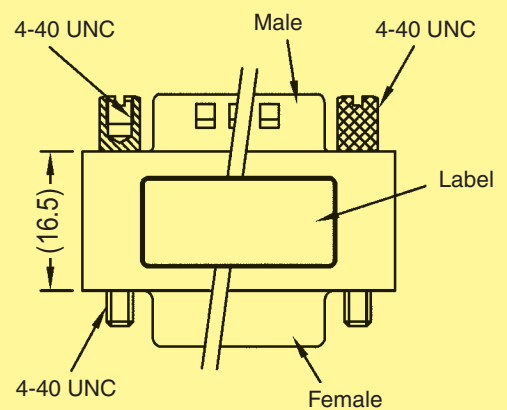
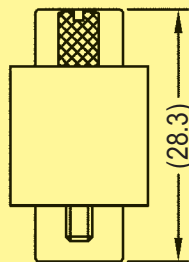
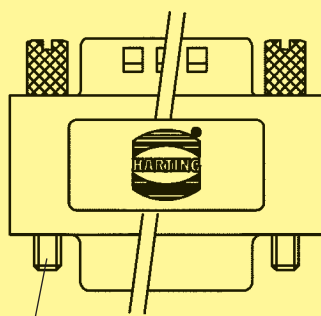
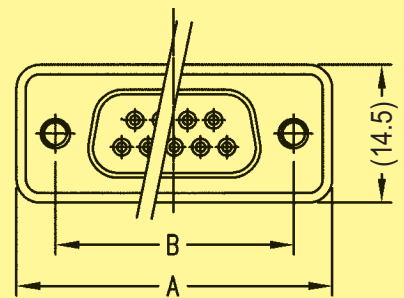

Screws are not pre-mounted to allow mounting from any ends

Number of contacts

**9–37**



Turned solder pins, straight, through hole

Identification	No. of contacts	Part No.	
		male connectors	female connectors
Connectors with <b>47 pF</b> C filter	9	09 64 122 7210	09 64 112 7210
	15	09 64 222 7210	09 64 212 7210
	25	09 64 322 7210	09 64 312 7210
	37	09 64 422 7210	09 64 412 7210
Connectors with <b>470 pF</b> C filter	9	09 64 122 7220	09 64 112 7220
	15	09 64 222 7220	09 64 212 7220
	25	09 64 322 7220	09 64 312 7220
	37	09 64 422 7220	09 64 412 7220
Connectors with <b>1000 pF</b> C filter	9	09 64 122 7230	09 64 112 7230
	15	09 64 222 7230	09 64 212 7230
	25	09 64 322 7230	09 64 312 7230
	37	09 64 422 7230	09 64 412 7230
Connectors with <b>3900 pF</b> C filter	9	09 64 122 7240	09 64 112 7240
	15	09 64 222 7240	09 64 212 7240
	25	09 64 322 7240	09 64 312 7240
	37	09 64 422 7240	09 64 412 7240

D-Sub

Number of contacts

# 9-37



Turned solder pins, straight, through hole

Identification

Drawing

Dimensions in mm

Male connector

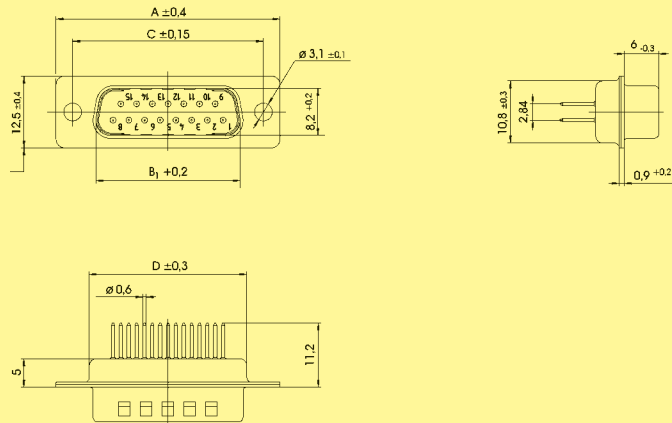

No. of contacts	A	B <sub>1</sub>	B <sub>2</sub>	C	D	E	F	G
9	30.8	16.9	16.4	25.00	19.3	1.37	2.74	12.50
15	39.1	25.2	24.7	33.30	27.5	1.37	2.74	16.65
25	53.0	38.9	38.5	47.04	41.3	1.40	2.77	23.52
37	69.3	55.3	54.9	63.50	57.7	1.40	2.77	31.75

Female connector

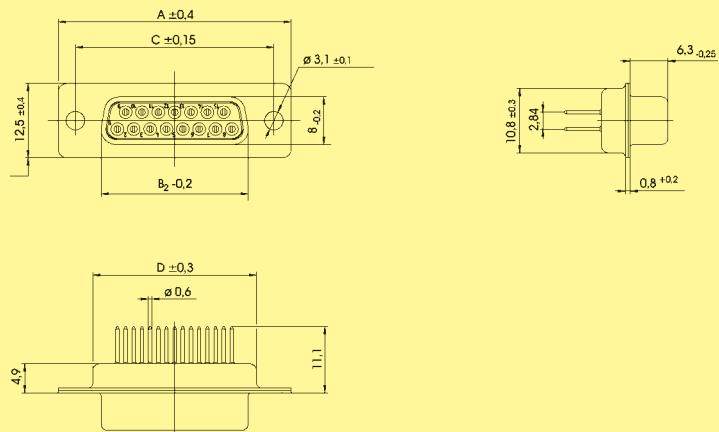

Board drillings

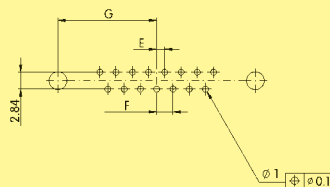



Number of contacts

**9-37**



Turned solder pins, straight, clinch nut

Identification	No. of contacts	Part No.	
		male connectors	female connectors
Connectors with <b>47 pF</b> C filter	9	09 64 122 721 .	09 64 112 721 .
	15	09 64 222 721 .	09 64 212 721 .
	25	09 64 322 721 .	09 64 312 721 .
	37	09 64 422 721 .	09 64 412 721 .
Connectors with <b>470 pF</b> C filter	9	09 64 122 722 .	09 64 112 722 .
	15	09 64 222 722 .	09 64 212 722 .
	25	09 64 322 722 .	09 64 312 722 .
	37	09 64 422 722 .	09 64 412 722 .
Connectors with <b>1000 pF</b> C filter	9	09 64 122 723 .	09 64 112 723 .
	15	09 64 222 723 .	09 64 212 723 .
	25	09 64 322 723 .	09 64 312 723 .
	37	09 64 422 723 .	09 64 412 723 .
Connectors with <b>3900 pF</b> C filter	9	09 64 122 724 .	09 64 112 724 .
	15	09 64 222 724 .	09 64 212 724 .
	25	09 64 322 724 .	09 64 312 724 .
	37	09 64 422 724 .	09 64 412 724 .
Please insert digit for flange thread	4-40 UNC ▶ 7		
	M3 ▶ 8		

D-Sub

Number of contacts

# 9-37



Turned solder pins, straight, clinch nut

Identification

Drawing

Dimensions in mm

Male connector

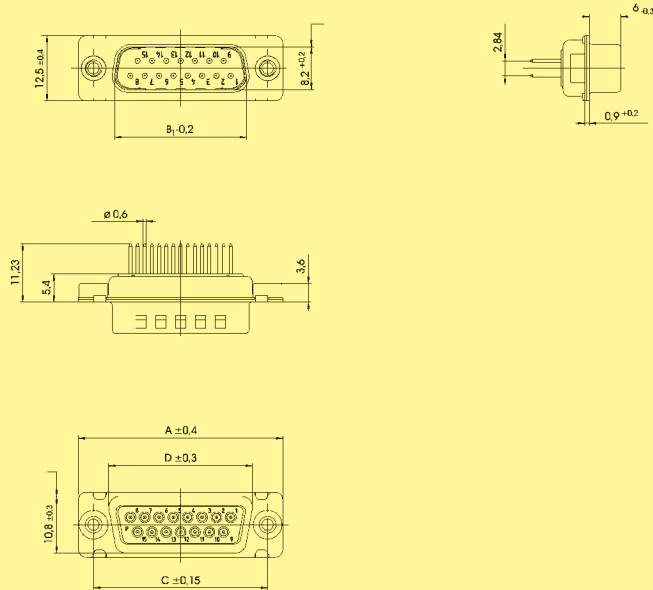

Female connector

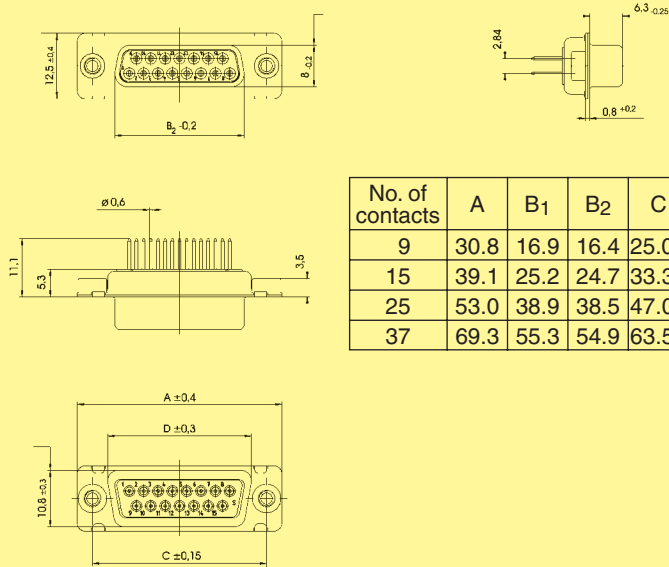

No. of contacts	A	B <sub>1</sub>	B <sub>2</sub>	C	D	E	F	G
9	30.8	16.9	16.4	25.00	19.3	1.37	2.74	12.50
15	39.1	25.2	24.7	33.30	27.5	1.37	2.74	16.65
25	53.0	38.9	38.5	47.04	41.3	1.40	2.77	23.52
37	69.3	55.3	54.9	63.50	57.7	1.40	2.77	31.75

Board drillings

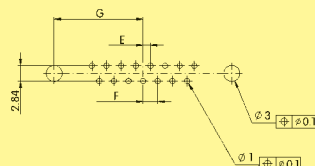

Number of contacts

**9-37**



Turned solder pins, straight, straight board clips

Identification	No. of contacts	Part No.	
		male connectors	female connectors
Connectors with <b>47 pF</b> C filter	9	09 64 122 721 .	09 64 112 721 .
	15	09 64 222 721 .	09 64 212 721 .
	25	09 64 322 721 .	09 64 312 721 .
	37	09 64 422 721 .	09 64 412 721 .
Connectors with <b>470 pF</b> C filter	9	09 64 122 722 .	09 64 112 722 .
	15	09 64 222 722 .	09 64 212 722 .
	25	09 64 322 722 .	09 64 312 722 .
	37	09 64 422 722 .	09 64 412 722 .
Connectors with <b>1000 pF</b> C filter	9	09 64 122 723 .	09 64 112 723 .
	15	09 64 222 723 .	09 64 212 723 .
	25	09 64 322 723 .	09 64 312 723 .
	37	09 64 422 723 .	09 64 412 723 .
Connectors with <b>3900 pF</b> C filter	9	09 64 122 724 .	09 64 112 724 .
	15	09 64 222 724 .	09 64 212 724 .
	25	09 64 322 724 .	09 64 312 724 .
	37	09 64 422 724 .	09 64 412 724 .
Please insert digit for flange thread	4-40 UNC ▶	5	
	M3 ▶	6	

D-Sub

Number of contacts

# 9-37



Turned solder pins, straight, straight board clips

Identification

Drawing

Dimensions in mm

Male connector

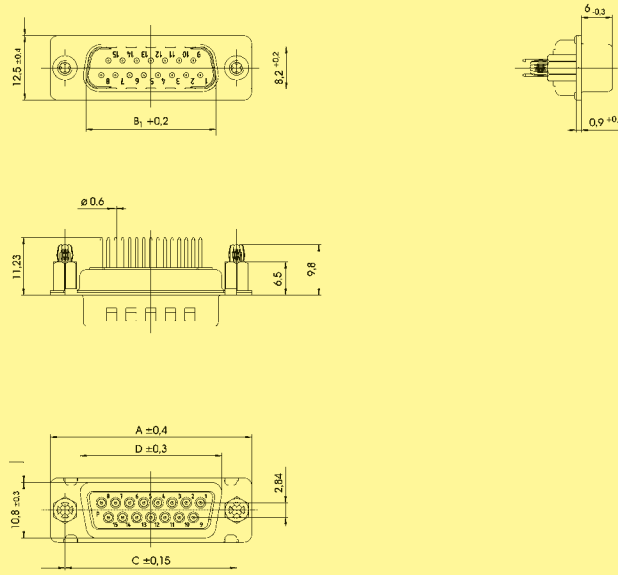

Female connector

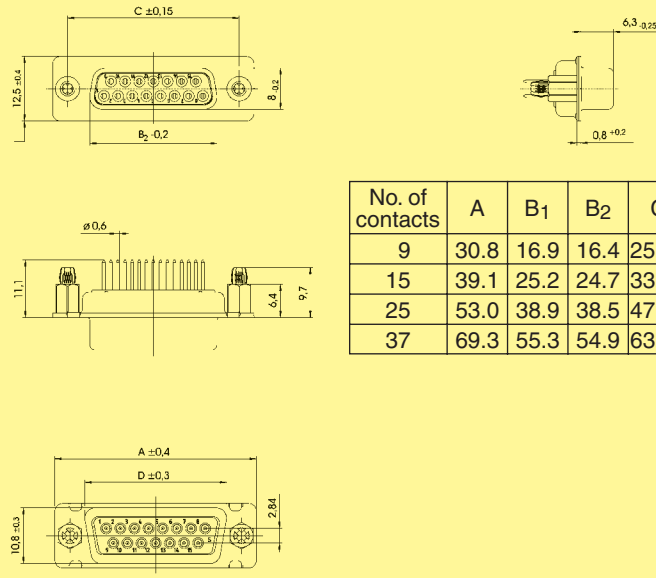

No. of contacts	A	B1	B2	C	D	E	F	G
9	30.8	16.9	16.4	25.00	19.3	1.37	2.74	12.50
15	39.1	25.2	24.7	33.30	27.5	1.37	2.74	16.65
25	53.0	38.9	38.5	47.04	41.3	1.40	2.77	23.52
37	69.3	55.3	54.9	63.50	57.7	1.40	2.77	31.75

Board drillings

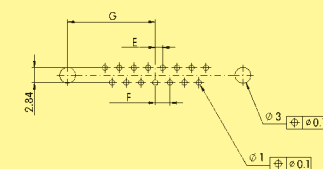

Number of contacts

**9-37**

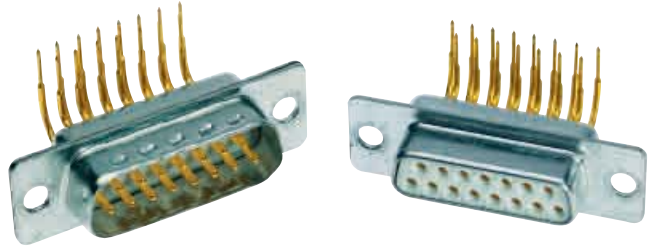

Turned solder pins, right angled, through hole

Identification	No. of contacts	Part No.	
		male connectors	female connectors
Connectors with <b>47 pF</b> C filter	9	09 64 124 7210	09 64 114 7210
	15	09 64 224 7210	09 64 214 7210
	25	09 64 324 7210	09 64 314 7210
	37	09 64 424 7210	09 64 414 7210
Connectors with <b>470 pF</b> C filter	9	09 64 124 7220	09 64 114 7220
	15	09 64 224 7220	09 64 214 7220
	25	09 64 324 7220	09 64 314 7220
	37	09 64 424 7220	09 64 414 7220
Connectors with <b>1000 pF</b> C filter	9	09 64 124 7230	09 64 114 7230
	15	09 64 224 7230	09 64 214 7230
	25	09 64 324 7230	09 64 314 7230
	37	09 64 424 7230	09 64 414 7230
Connectors with <b>3900 pF</b> C filter	9	09 64 124 7240	09 64 114 7240
	15	09 64 224 7240	09 64 214 7240
	25	09 64 324 7240	09 64 314 7240
	37	09 64 424 7240	09 64 414 7240

D-Sub

Number of contacts

9-37

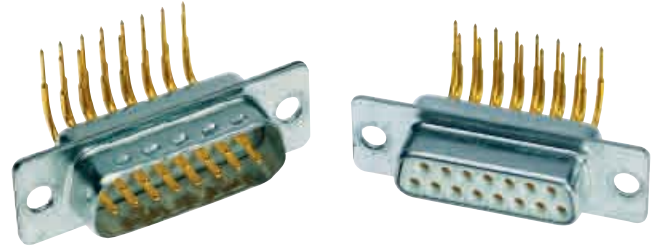

Turned solder pins, right angled, through hole

Identification

Drawing

Dimensions in mm

Male connector

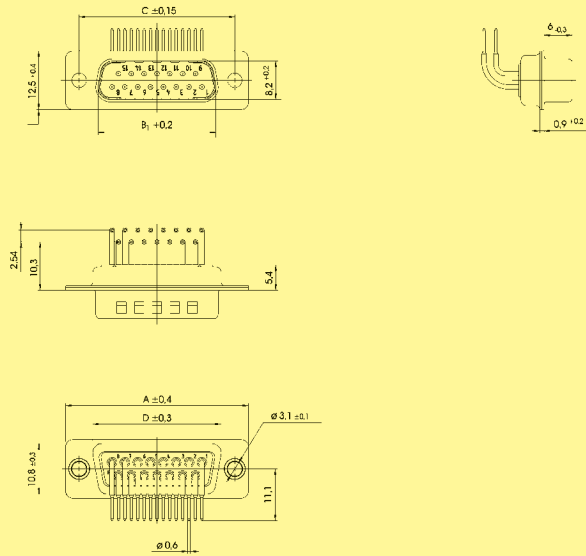

Female connector

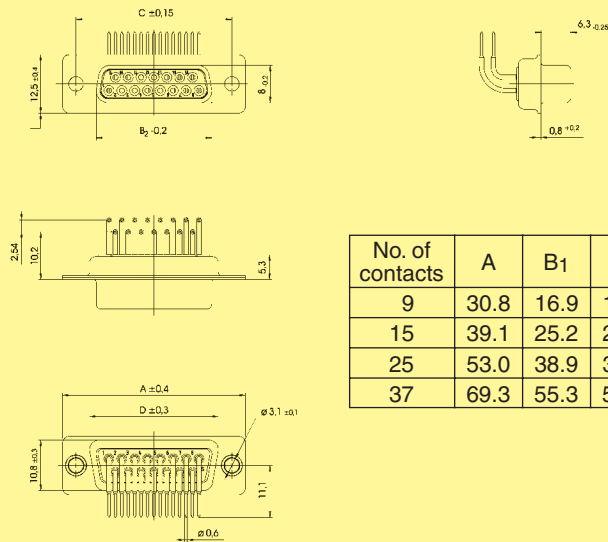

No. of contacts	A	B1	B2	C	D	E	F
9	30.8	16.9	16.4	25.00	19.3	1.37	2.74
15	39.1	25.2	24.7	33.30	27.5	1.37	2.74
25	53.0	38.9	38.5	47.04	41.3	1.40	2.77
37	69.3	55.3	54.9	63.50	57.7	1.40	2.77

Board drillings

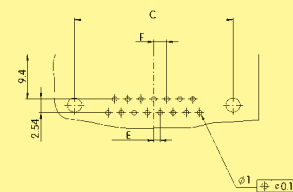

Number of contacts

**9-37**



Turned solder pins, right angled, bracket, board lock and through hole

Identification	No. of contacts	Part No.	
		male connectors	female connectors
Connectors with <b>47 pF</b> C filter	9	09 64 124 7211	09 64 114 7211
	15	09 64 224 7211	09 64 214 7211
	25	09 64 324 7211	09 64 314 7211
	37	09 64 424 7211	09 64 414 7211
Connectors with <b>470 pF</b> C filter	9	09 64 124 7221	09 64 114 7221
	15	09 64 224 7221	09 64 214 7221
	25	09 64 324 7221	09 64 314 7221
	37	09 64 424 7221	09 64 414 7221
Connectors with <b>1000 pF</b> C filter	9	09 64 124 7231	09 64 114 7231
	15	09 64 224 7231	09 64 214 7231
	25	09 64 324 7231	09 64 314 7231
	37	09 64 424 7231	09 64 414 7231
Connectors with <b>3900 pF</b> C filter	9	09 64 124 7241	09 64 114 7241
	15	09 64 224 7241	09 64 214 7241
	25	09 64 324 7241	09 64 314 7241
	37	09 64 424 7241	09 64 414 7241

D-Sub

Number of contacts

# 9-37



Turned solder pins, right angled, bracket, board lock and through hole

Identification

Drawing

Dimensions in mm

Male connector

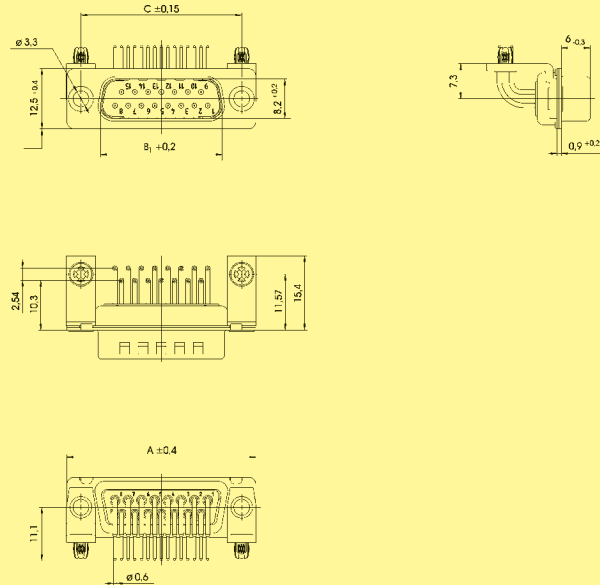

Female connector

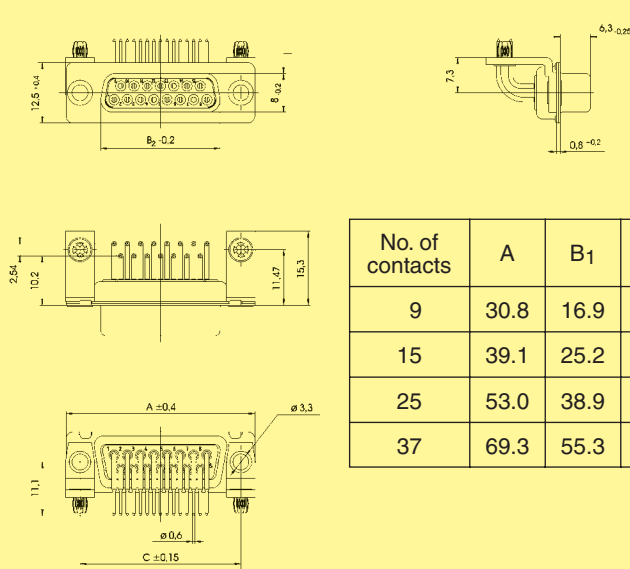

No. of contacts	A	B <sub>1</sub>	B <sub>2</sub>	C	E	F
9	30.8	16.9	16.4	25.00	1.37	2.74
15	39.1	25.2	24.7	33.30	1.37	2.74
25	53.0	38.9	38.5	47.04	1.40	2.77
37	69.3	55.3	54.9	63.50	1.40	2.77

Board drillings

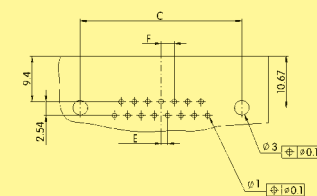



Number of contacts

**9-37**

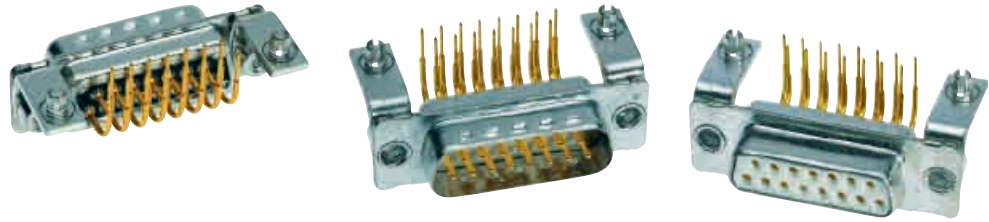

Turned solder pins, right angled, bracket, board lock and clinch nut

Identification	No. of contacts	Part No.	
		male connectors	female connectors
Connectors with <b>47 pF C filter</b>	9	09 64 124 721 .	09 64 114 721 .
	15	09 64 224 721 .	09 64 214 721 .
	25	09 64 324 721 .	09 64 314 721 .
	37	09 64 424 721 .	09 64 414 721 .
Connectors with <b>470 pF C filter</b>	9	09 64 124 722 .	09 64 114 722 .
	15	09 64 224 722 .	09 64 214 722 .
	25	09 64 324 722 .	09 64 314 722 .
	37	09 64 424 722 .	09 64 414 722 .
Connectors with <b>1000 pF C filter</b>	9	09 64 124 723 .	09 64 114 723 .
	15	09 64 224 723 .	09 64 214 723 .
	25	09 64 324 723 .	09 64 314 723 .
	37	09 64 424 723 .	09 64 414 723 .
Connectors with <b>3900 pF C filter</b>	9	09 64 124 724 .	09 64 114 724 .
	15	09 64 224 724 .	09 64 214 724 .
	25	09 64 324 724 .	09 64 314 724 .
	37	09 64 424 724 .	09 64 414 724 .
Please insert digit for flange thread	4-40 UNC ▶	2	
	M3 ▶	3	

D-Sub

Number of contacts

# 9-37

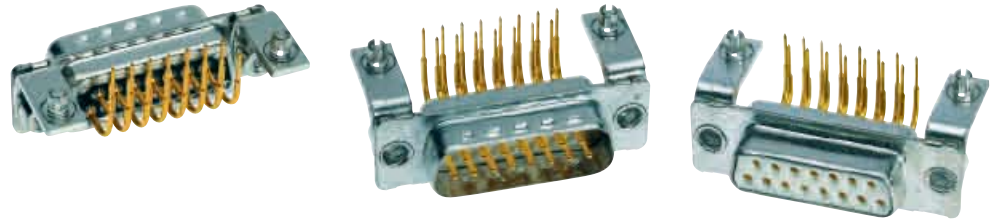

Turned solder pins, right angled, bracket, board lock and clinch nut

Identification

Drawing

Dimensions in mm

Male connector

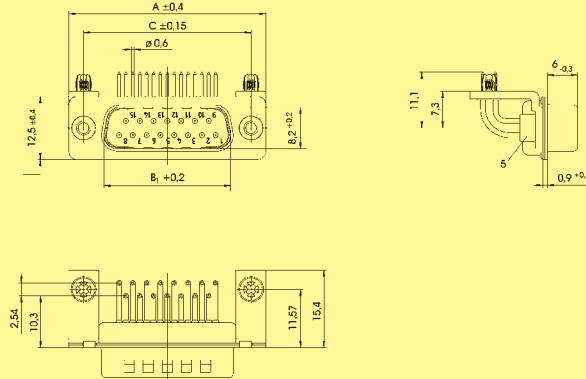

No. of contacts	A	B <sub>1</sub>	B <sub>2</sub>	C	E	F
9	30.8	16.9	16.4	25.00	1.37	2.74
15	39.1	25.2	24.7	33.30	1.37	2.74
25	53.0	38.9	38.5	47.04	1.40	2.77
37	69.3	55.3	54.9	63.50	1.40	2.77

Female connector

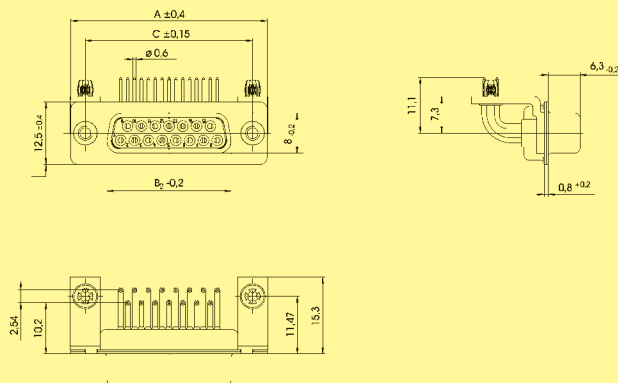

Board drillings

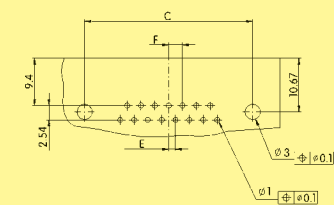

Number of contacts

9-37



Turned solder pins, right angled, bracket and clinch nut

Identification	No. of contacts	Part No.	
		male connectors	female connectors
Connectors with <b>47 pF C filter</b>	9	09 64 124 721 .	09 64 114 721 .
	15	09 64 224 721 .	09 64 214 721 .
	25	09 64 324 721 .	09 64 314 721 .
	37	09 64 424 721 .	09 64 414 721 .
Connectors with <b>470 pF C filter</b>	9	09 64 124 722 .	09 64 114 722 .
	15	09 64 224 722 .	09 64 214 722 .
	25	09 64 324 722 .	09 64 314 722 .
	37	09 64 424 722 .	09 64 414 722 .
Connectors with <b>1000 pF C filter</b>	9	09 64 124 723 .	09 64 114 723 .
	15	09 64 224 723 .	09 64 214 723 .
	25	09 64 324 723 .	09 64 314 723 .
	37	09 64 424 723 .	09 64 414 723 .
Connectors with <b>3900 pF C filter</b>	9	09 64 124 724 .	09 64 114 724 .
	15	09 64 224 724 .	09 64 214 724 .
	25	09 64 324 724 .	09 64 314 724 .
	37	09 64 424 724 .	09 64 414 724 .
Please insert digit for flange thread	4-40 UNC ▶ 6		
	M3 ▶ 7		

D-Sub

Number of contacts

# 9-37

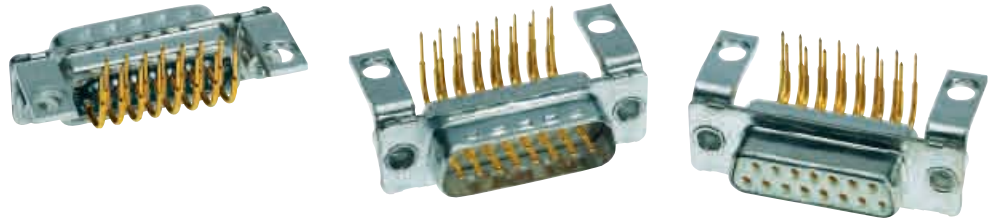

Turned solder pins, right angled, bracket and clinch nut

Identification

Drawing

Dimensions in mm

Male connector

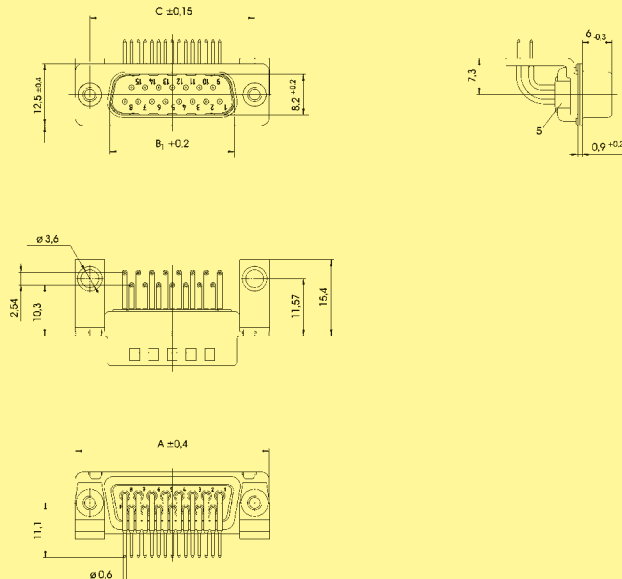

Female connector

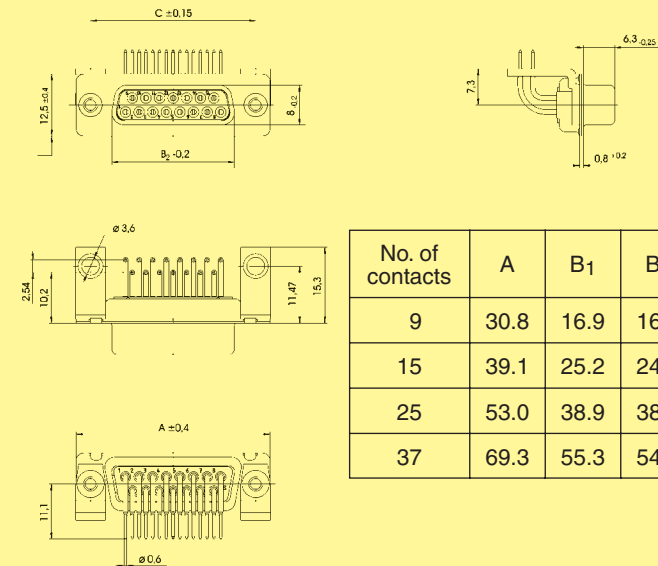

No. of contacts	A	B <sub>1</sub>	B <sub>2</sub>	C	E	F
9	30.8	16.9	16.4	25.00	1.37	2.74
15	39.1	25.2	24.7	33.30	1.37	2.74
25	53.0	38.9	38.5	47.04	1.40	2.77
37	69.3	55.3	54.9	63.50	1.40	2.77

Board drillings

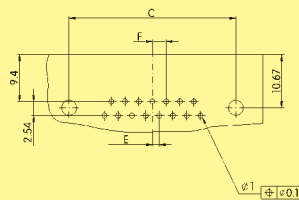

Number of contacts

9-37



Turned solder pins, right angled, bracket, board lock and female screw

Identification	No. of contacts	Part No.	
		male connectors	female connectors
Connectors with <b>47 pF C filter</b>	9	09 64 124 721 .	09 64 114 721 .
	15	09 64 224 721 .	09 64 214 721 .
	25	09 64 324 721 .	09 64 314 721 .
	37	09 64 424 721 .	09 64 414 721 .
Connectors with <b>470 pF C filter</b>	9	09 64 124 722 .	09 64 114 722 .
	15	09 64 224 722 .	09 64 214 722 .
	25	09 64 324 722 .	09 64 314 722 .
	37	09 64 424 722 .	09 64 414 722 .
Connectors with <b>1000 pF C filter</b>	9	09 64 124 723 .	09 64 114 723 .
	15	09 64 224 723 .	09 64 214 723 .
	25	09 64 324 723 .	09 64 314 723 .
	37	09 64 424 723 .	09 64 414 723 .
Connectors with <b>3900 pF C filter</b>	9	09 64 124 724 .	09 64 114 724 .
	15	09 64 224 724 .	09 64 214 724 .
	25	09 64 324 724 .	09 64 314 724 .
	37	09 64 424 724 .	09 64 414 724 .
Please insert digit for flange thread	4-40 UNC ▶	4	
	M3 ▶	5	

D-Sub

Number of contacts

# 9-37



Turned solder pins, right angled, bracket, board lock and female screw

Identification

Drawing

Dimensions in mm

Male connector

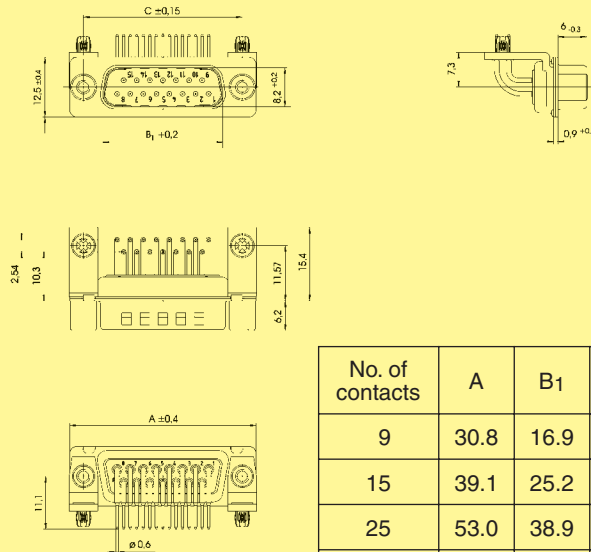

No. of contacts	A	B <sub>1</sub>	B <sub>2</sub>	C	E	F
9	30.8	16.9	16.4	25.00	1.37	2.74
15	39.1	25.2	24.7	33.30	1.37	2.74
25	53.0	38.9	38.5	47.04	1.40	2.77
37	69.3	55.3	54.9	63.50	1.40	2.77

Female connector

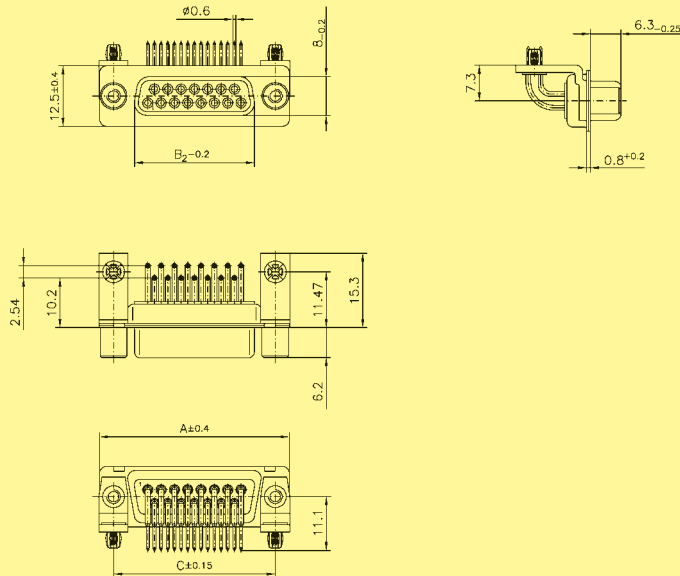

Board drillings

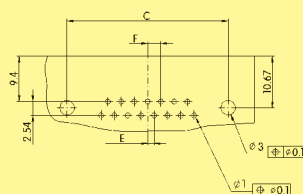

Number of contacts

9-37



Turned solder pins, right angled, bracket and female screw

Identification	No. of contacts	Part No.	
		male connectors	female connectors
Connectors with <b>47 pF C filter</b>	9	09 64 124 721 .	09 64 114 721 .
	15	09 64 224 721 .	09 64 214 721 .
	25	09 64 324 721 .	09 64 314 721 .
	37	09 64 424 721 .	09 64 414 721 .
Connectors with <b>470 pF C filter</b>	9	09 64 124 722 .	09 64 114 722 .
	15	09 64 224 722 .	09 64 214 722 .
	25	09 64 324 722 .	09 64 314 722 .
	37	09 64 424 722 .	09 64 414 722 .
Connectors with <b>1000 pF C filter</b>	9	09 64 124 723 .	09 64 114 723 .
	15	09 64 224 723 .	09 64 214 723 .
	25	09 64 324 723 .	09 64 314 723 .
	37	09 64 424 723 .	09 64 414 723 .
Connectors with <b>3900 pF C filter</b>	9	09 64 124 724 .	09 64 114 724 .
	15	09 64 224 724 .	09 64 214 724 .
	25	09 64 324 724 .	09 64 314 724 .
	37	09 64 424 724 .	09 64 414 724 .
Please insert digit for flange thread	4-40 UNC ▶	8	
	M3 ▶	9	

D-Sub

Number of contacts

# 9-37



Turned solder pins, right angled, bracket and female screw

Identification

Drawing

Dimensions in mm

Male connector

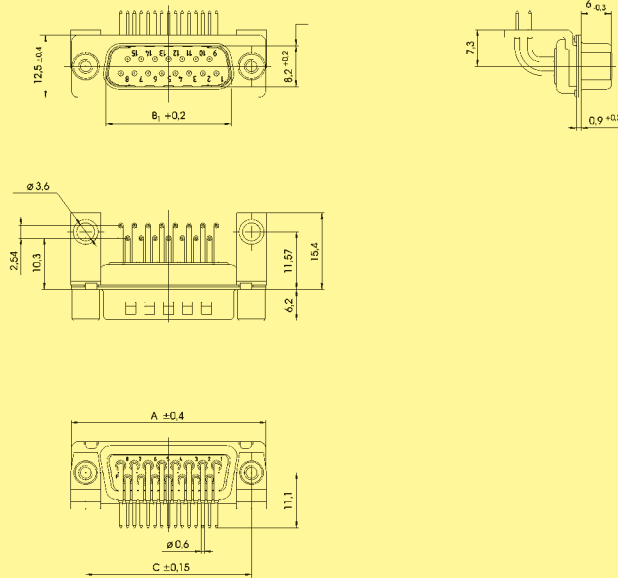

Female connector

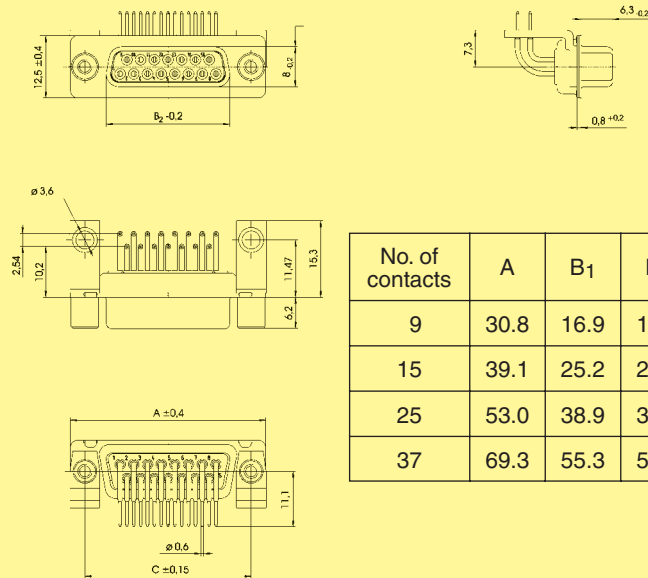

No. of contacts	A	B <sub>1</sub>	B <sub>2</sub>	C	E	F
9	30.8	16.9	16.4	25.00	1.37	2.74
15	39.1	25.2	24.7	33.30	1.37	2.74
25	53.0	38.9	38.5	47.04	1.40	2.77
37	69.3	55.3	54.9	63.50	1.40	2.77

Board drillings

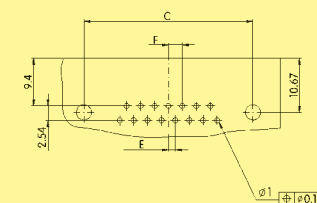



Number of contacts

**9-37**



Solder buckets, through hole

Identification	No. of contacts	Part No.	
		male connectors	female connectors
Connectors with <b>47 pF</b> C filter	9	09 64 121 7210	09 64 111 7210
	15	09 64 221 7210	09 64 211 7210
	25	09 64 321 7210	09 64 311 7210
	37	09 64 421 7210	09 64 411 7210
Connectors with <b>470 pF</b> C filter	9	09 64 121 7220	09 64 111 7220
	15	09 64 221 7220	09 64 211 7220
	25	09 64 321 7220	09 64 311 7220
	37	09 64 421 7220	09 64 411 7220
Connectors with <b>1000 pF</b> C filter	9	09 64 121 7230	09 64 111 7230
	15	09 64 221 7230	09 64 211 7230
	25	09 64 321 7230	09 64 311 7230
	37	09 64 421 7230	09 64 411 7230
Connectors with <b>3900 pF</b> C filter	9	09 64 121 7240	09 64 111 7240
	15	09 64 221 7240	09 64 211 7240
	25	09 64 321 7240	09 64 311 7240
	37	09 64 421 7240	09 64 411 7240

D-Sub

Number of contacts

# 9-37



Solder buckets, through hole

Identification

Drawing

Dimensions in mm

Male connector

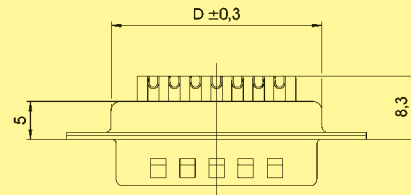
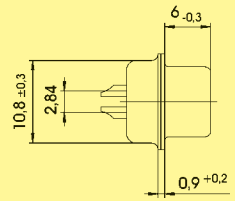
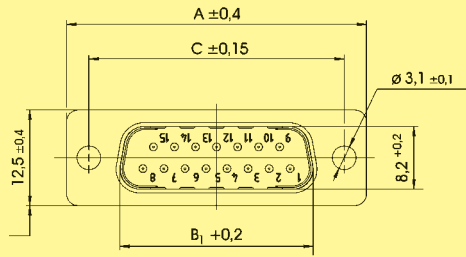

No. of contacts	A	B1	B2	C	D
9	30.8	16.9	16.4	25.00	19.3
15	39.1	25.2	24.7	33.30	27.5
25	53.0	38.9	38.5	47.04	41.3
37	69.3	55.3	54.9	63.50	57.7

Female connector

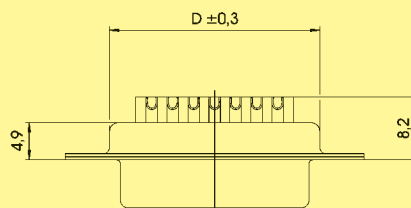
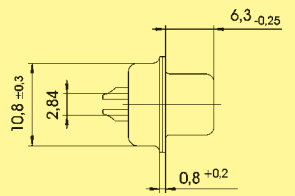
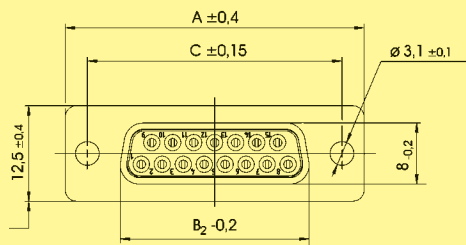

D-Sub

Number of contacts

# 9-37



Solder buckets, clinch nut

Identification	No. of contacts	Part No.	
		male connectors	female connectors
Connectors with <b>47 pF C filter</b>	9	09 64 121 721 .	09 64 111 721 .
	15	09 64 221 721 .	09 64 211 721 .
	25	09 64 321 721 .	09 64 311 721 .
	37	09 64 421 721 .	09 64 411 721 .
Connectors with <b>470 pF C filter</b>	9	09 64 121 722 .	09 64 111 722 .
	15	09 64 221 722 .	09 64 211 722 .
	25	09 64 321 722 .	09 64 311 722 .
	37	09 64 421 722 .	09 64 411 722 .
Connectors with <b>1000 pF C filter</b>	9	09 64 121 723 .	09 64 111 723 .
	15	09 64 221 723 .	09 64 211 723 .
	25	09 64 321 723 .	09 64 311 723 .
	37	09 64 421 723 .	09 64 411 723 .
Connectors with <b>3900 pF C filter</b>	9	09 64 121 724 .	09 64 111 724 .
	15	09 64 221 724 .	09 64 211 724 .
	25	09 64 321 724 .	09 64 311 724 .
	37	09 64 421 724 .	09 64 411 724 .
Please insert digit for flange thread	4-40 UNC ▶ 7		
	M3 ▶ 8		

D-Sub

Number of contacts

# 9-37



Solder buckets, clinch nut

Identification

Drawing

Dimensions in mm

Male connector

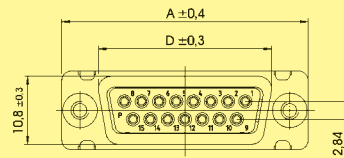
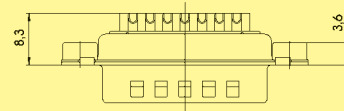
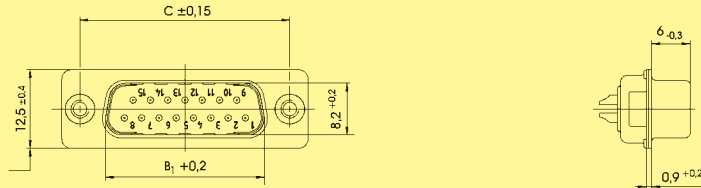

No. of contacts	A	B1	B2	C	D
9	30.8	16.9	16.4	25.00	19.3
15	39.1	25.2	24.7	33.30	27.5
25	53.0	38.9	38.5	47.04	41.3
37	69.3	55.3	54.9	63.50	57.7

Female connector

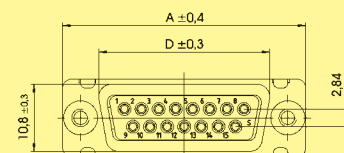
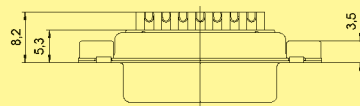
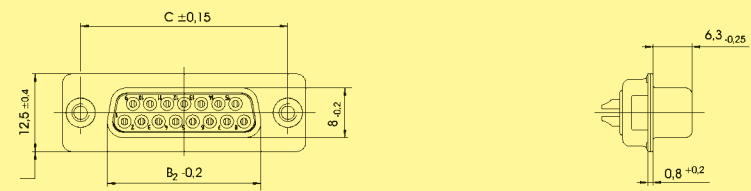

## Panel cut outs / panel mountings

### Panel cut outs

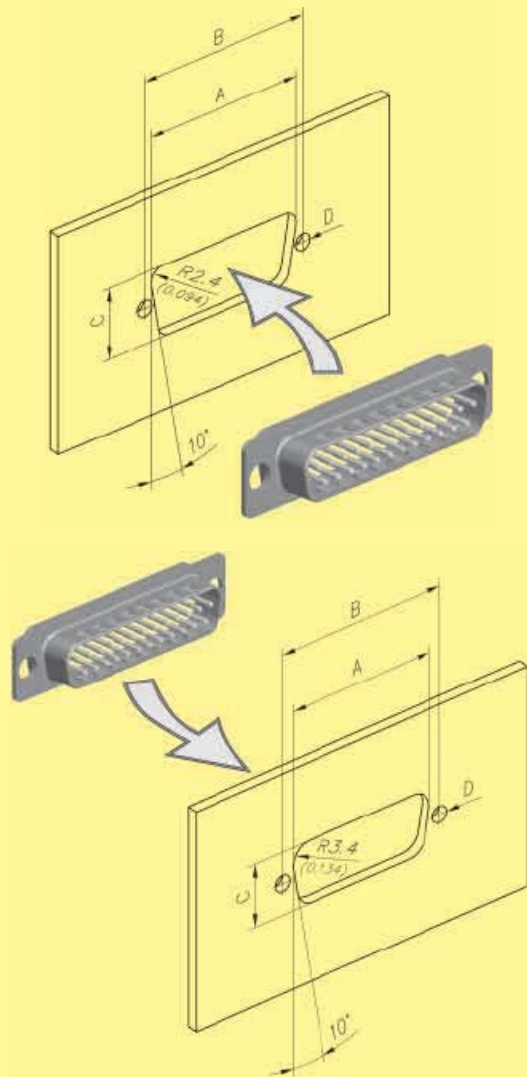

Front mounting

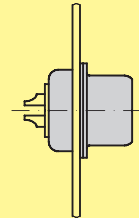

Rear mounting

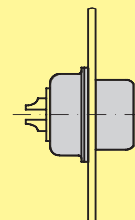

No. of contacts	Mounting assembly	A ± 0.2	B ± 0.2	C ± 0.2
9	Front	22.2	25.0	12.3
	Rear	20.5	25.0	11.4
15	Front	30.5	33.3	12.3
	Rear	28.8	33.3	11.4
25	Front	44.3	47.0	12.3
	Rear	42.5	47.0	11.4
37	Front	60.7	63.5	12.3
	Rear	59.1	63.5	11.4

### Panel mountings

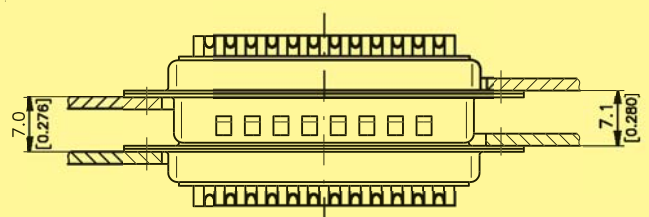
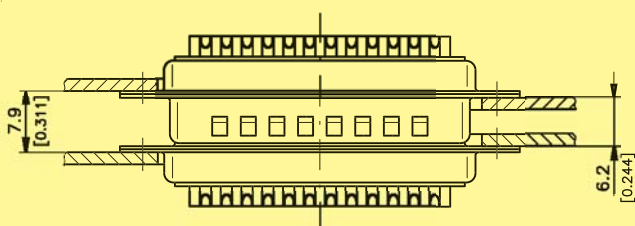

## General information

With the innovative EMC platform approach, this enables customers to select their optimum filter requirements, contact per contact. Allowing not only to segregate the filtering per contact but also to mix the type of filter used. This is then cast in a single competitive product (in a standard D-Sub shell).

The biggest advantage of the HARTING technology is that multiple filter assemblies can be configured to create different filter designs: C, Pi, L and T types. Since any value of capacitor can be placed on any contact, a wide range of configurations can be built, it is even possible to have an individual pin unfiltered if necessary.

Furthermore, ***Pi filters can be supplied in a standard connector size shell.*** In addition, protection against lightening and transient voltage can be included upon request.

In the next few pages, you will find all the necessary information plus a selection guide to help you to choose your appropriate solution.



or

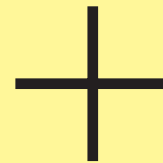

- C filter
- L filter
- Pi filter
- ESD protection
- Lightening protection
- Combination



With any capacitance on any pin in a **standard D-Sub shell.**

## General information

### Filter possibilities

#### C filter:

Non exhaustive list of C filter values that HARTING can supply (for specials see page 05.120 ff)

C filter capacitance in pF	Minimum insertion loss								Max. working voltage	Max. dielectric withstanding
	Attenuation [dB] vs frequency [MHz]									
	0.1	1	5	10	50	100	500	1000		
47						30	35	500 V DC	750 V DC	
100					1	3	40	35	500 V DC	750 V DC
150					1	6	45	35	500 V DC	750 V DC
180					1	10	40	32	500 V DC	750 V DC
270				1	3	12	35	32	500 V DC	750 V DC
330				1	7	13	35	32	500 V DC	750 V DC
470				1	10	15	35	32	500 V DC	750 V DC
820				2	10	18	30	30	500 V DC	750 V DC
1000			1	3	12	20	34	30	500 V DC	750 V DC
1800			2	6	17	30	35	32	500 V DC	750 V DC
3900		1	6	11	25	35	35	32	500 V DC	750 V DC
4700		1	9	13	30	38	35	32	500 V DC	750 V DC
5600		2	10	14	30	32	32	32	500 V DC	750 V DC
10000		1	10	15	30	32	30	30	200 V DC	500 V DC
33000	1	9	19	29	32	34	39	32	100 V DC	150 V DC
47000	1	11	23	30	32	32	35	32	100 V DC	150 V DC
100000	2	18	32	40	34	34	36	35	25 V DC	40 V DC

#### Pi filter:

Non exhaustive list of Pi filter values that HARTING can supply (for specials see page 05.120 ff)

Pi filter capacitance in pF	Minimum insertion loss								Max. working voltage	Max. dielectric withstanding
	Attenuation [dB] vs frequency [MHz]									
	0.1	1	5	10	50	100	500	1000		
94						2	35	50	200 V DC	500 V DC
200					1	8	50	40	200 V DC	500 V DC
440				1	8	16	50	40	200 V DC	500 V DC
940				2	12	24	50	40	200 V DC	500 V DC
2000			2	7	17	40	45	40	200 V DC	500 V DC
4400			5	10	28	60	45	40	200 V DC	500 V DC
9400		2	10	15	48	50	45	40	200 V DC	500 V DC
20000		5	14	20	50	60	52	48	100 V DC	250 V DC
94000	2	15	32	50	51	52	48	42	50 V DC	125 V DC
200000	7	21	48	65	55	52	48	42	16 V DC	25 V DC

## General information

### Other protection possibilities

#### ESD protection

(Electro Static Discharge protection)

For equipment to comply with:

- IEC-1000-4-2; levels 1 to 4 (Contact discharge test)
- RTCA-160 D; section 25

Typical parasitic capacitance (pF)	Max. clamp voltage (V)	Working voltage (V)
0.5 V <sub>rms</sub> @ 1 KHz	@ I = 1 A @ 8/20 μS	@ I = 10 μA
1750	7.5	3
1250	13	5
650	22	12
430	33	18
220	48	26
200	51	30

#### EMP protection

(Electro Magnetic Pulse protection)

For equipment to comply with:

- MIL-STD-461 C: requirements CS 06, CS 10, CS 11, RS 05
- IEC-1000-4-4; EFT TESTS
- RTCA-160 D; section 17

Typical parasitic capacitance (pF)	Max. clamp voltage (V)	Working voltage (V)
0.5 V <sub>rms</sub> @ 1 KHz	@ I = 10 A @ 8/20 μS	@ I = 10 μA
5675	9	3
3620	15	5
1500	26	14
820	34	18
275	50	26

#### Lightening protection

For equipment to comply with:

- IEC-1000-4-5; levels 1 and 2 (1.2 μ / 50 μS)
- RTCA-160 D; section 22 (pin injection, level 1)

Typical parasitic capacitance (pF)	Max. clamp voltage (V)	Working voltage (V)
0.5 V <sub>rms</sub> @ 1 KHz	@ I = 30 A @ 8/20 μS	@ I = 10 μA
5500	12	3
3175	18	5
2000	21	9
1680	30	14
900	38	18
720	60	26
600	63	30



# HARTING customer request form

Our innovative technology offers all the possibilities you may need.  
 For customer solutions, please contact your local HARTING representative.  
 Here is a summary of the information we need to develop a customer solution:

## Connector

Standard D-Sub

Gender  Male  Female

No. of contacts  9  15  25  37  50

Termination  Solder bucket  Straight pcb

R/A Eur, 2.54 mm  R/A US, 2.84 mm

Mixed D-Sub

Gender  Male  Female

Contact arrangement  3W3  3W3C  Other \_\_\_\_\_

Power contact rating  10 A  20 A  30 A  40 A

Termination  Solder bucket  Straight pcb

R/A pcb (please specify the board drillings)

## Flange thread and board locking options

### Right angled version

- Through hole
- Clinch nut 4-40 UNC
- Clinch nut M3
- Bracket
- Board lock
- Female screw lock 4-40 UNC
- Female screw lock M3

### Straight version

- Through hole
- Clinch nut 4-40 UNC
- Clinch nut M3
- Spacer 4-40 UNC
- Spacer M3
- Female screw lock 4-40 UNC
- Spacer 4-40 UNC + board lock
- Spacer M3 + board lock
- Spacer + board lock and female screw lock
  - M3
  - 4-40 UNC

D-Sub

## HARTING customer request from

### Filter

What working voltage is used? \_\_\_\_\_

What is the maximum dielectric withstanding voltage needed? \_\_\_\_\_

Type of filter \_\_\_\_\_ (C filter, Pi filter, L filter ...)

Capacitance \_\_\_\_\_

Are there other protections needed?  No  
 Yes

ESD  Transient  
 EMP  Lightening

If a pin-to-pin selection has to be done, please state the details

Pin 1: ?, Pin 2: ?, ...

Name: \_\_\_\_\_

Drawing:  no  yes

Company: \_\_\_\_\_

Samples:  no  yes, quantity

Address: \_\_\_\_\_

Volume (pcs./year): \_\_\_\_\_

Phone: \_\_\_\_\_

Special requirements: \_\_\_\_\_

Fax: \_\_\_\_\_

E-Mail: \_\_\_\_\_

Number of contacts 9, 15, 25, 37, 50  
UL recognized

Working current 5 A

Test voltage 1200 V for 1 minute  
between 2 contacts / contact and shell

Clearance and creepage  $\geq 1.0$  mm

Contact resistance  
Straight contact  $\leq 10$  m $\Omega$   
Angled contact  $\leq 25$  m $\Omega$   
Angled contact 50 pole  $\leq 35$  m $\Omega$

Insulation resistance between contacts  $\geq 5000$  M $\Omega$

Dielectric strength 50 kV/mm

Temperature range -25 °C ... +70 °C

Protection IP 67  
(per DIN 40050 / IEC 529)

Termination  
Solder cup max. AWG 20  
Solder pin straight 0.6 mm diameter  
Solder pin angled 0.6 mm diameter

Material  
Shell Brass, nickel plated  
Insulator and plastic watertight frame Thermoplastic, glass-fibre filled, UL 94-V0  
Metal watertight frame Nickel plated zinc die cast  
Contact material Machined copper alloy

Contact surface  
Contact zone 0.76  $\mu$ m Au min. over Ni

Waterproofing element Silicone

Mechanical  
Mating cycles  $\geq 500$   
Mating force per signal contact  $\leq 3.4$  N  
Unmating force per signal contact  $\geq 0.2$  N

Contact arrangement View from termination side

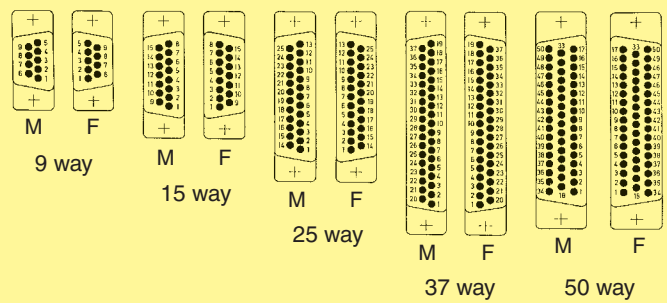

M = Male connector  
F = Female connector

Mating conditions as per DIN 41 652

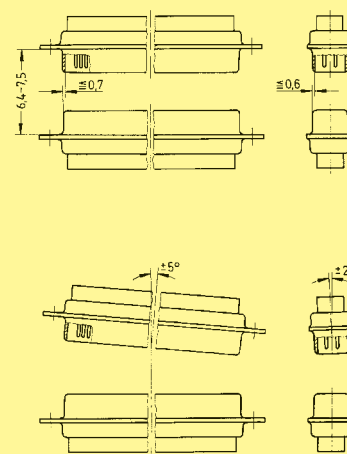



Number of contacts

9–50



IP 67, turned solder cups

Identification	No. of contacts	Part No.
		S4 <sup>1)</sup>
Male connector metal shell with dimples	9 15 25 37 50	09 67 409 5615 09 67 415 5615 09 67 425 5615 09 67 437 5615 09 67 450 5615
Female connector metal shell	9 15 25 37 50	09 67 409 4715 09 67 415 4715 09 67 425 4715 09 67 437 4715 09 67 450 4715

D-Sub

<sup>1)</sup> S4: ≥ 0.76 µm Au (30 µinch)

Number of contacts

# 9-50



IP 67, turned solder cups

Identification

Drawing

Dimensions in mm

**Male connector**  
9 – 50 contacts

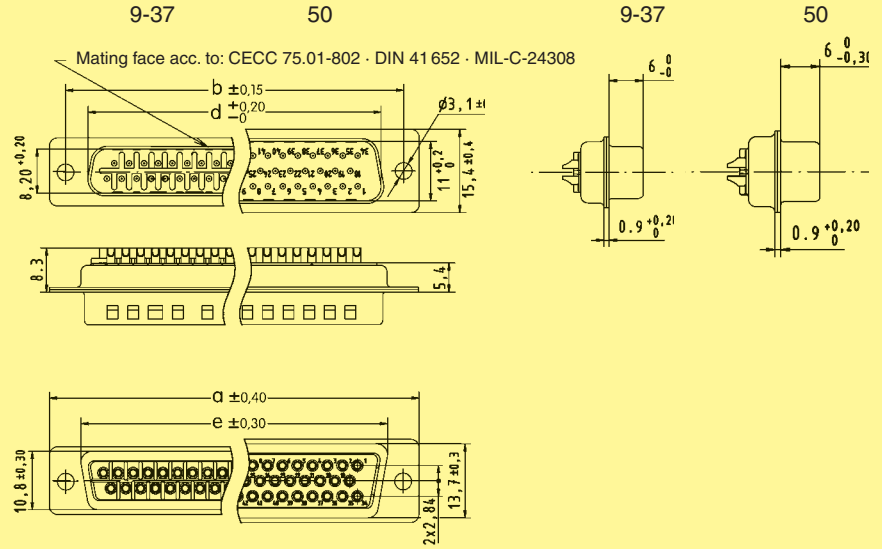

**Female connector**  
9 – 50 contacts

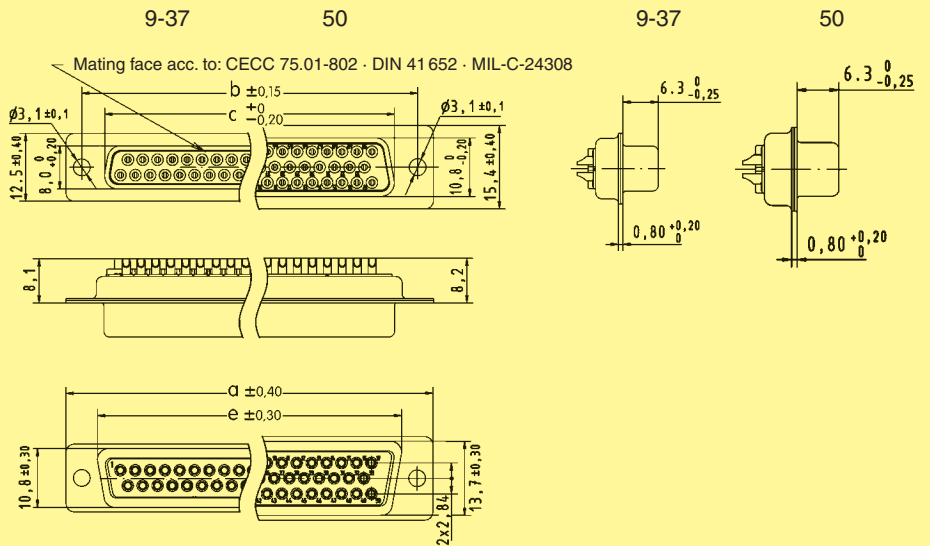

	a	b	c	d	e
9	30.8	25.00	16.4	16.9	19.3
15	39.1	33.30	24.7	25.2	27.5
25	53.0	47.04	38.5	38.9	41.3
37	69.3	63.50	54.9	55.3	57.7
50	66.9	61.10	52.5	52.8	55.3

Number of contacts

9–25



IP 67, turned solder cups, with rear plastic mounting plate

Identification	No. of contacts	Part No.	
		S4 <sup>1)</sup>	
<b>Male connector</b> metal shell with dimples  Please insert digit for flange thread  4-40 UNC ▶ 7 M3 ▶ 9	9 15 25	09 67 509 . 615 09 67 515 . 615 09 67 525 . 615	
<b>Female connector</b> metal shell  Please insert digit for flange thread  4-40 UNC ▶ 6 M3 ▶ 8	9 15 25	09 67 509 . 715 09 67 515 . 715 09 67 525 . 715	

D-Sub

<sup>1)</sup> S4: ≥ 0.76 µm Au (30 µinch)

Number of contacts

# 9-25



IP 67, turned solder cups, with rear plastic mounting plate

Identification

Drawing

Dimensions in mm

**Male connector**  
9 – 25 contacts

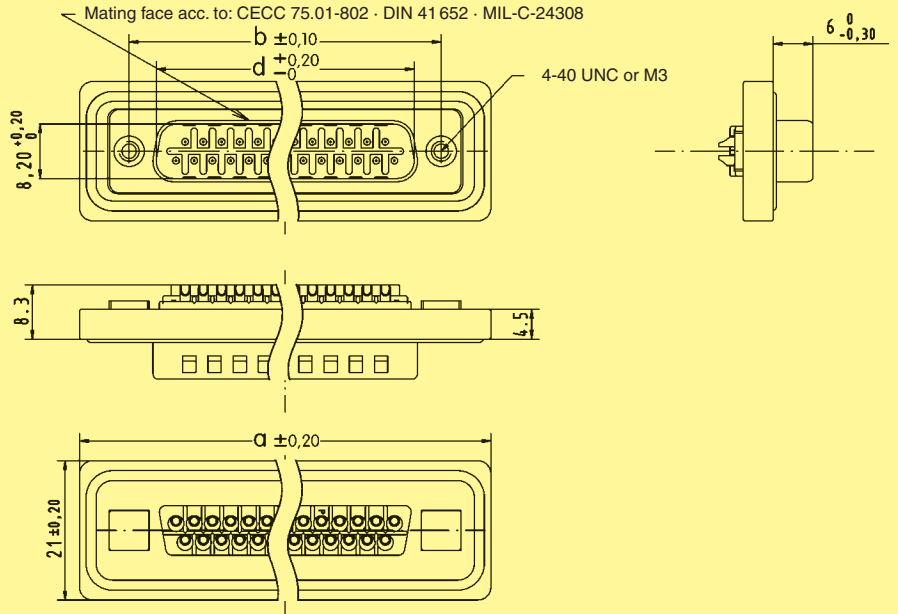

**Female connector**  
9 – 25 contacts

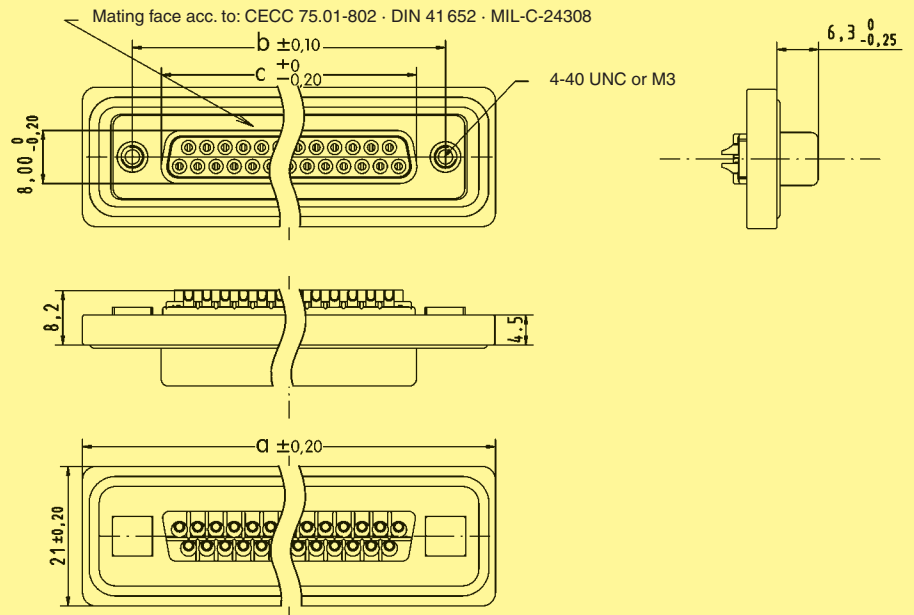

	a	b	c	d
9	40.0	25.00	16.4	16.9
15	48.3	33.30	24.7	25.2
25	62.0	47.04	38.5	38.9



Number of contacts

9–25

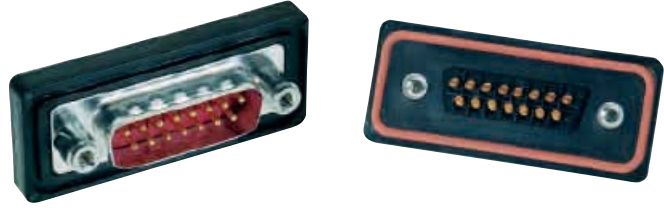

IP 67, turned solder cups, with front plastic mounting plate

Identification	No. of contacts	Part No.	
		S4 <sup>1)</sup>	
Male connector metal shell with dimples	9 15 25	09 67 709 . 615 09 67 715 . 615 09 67 725 . 615	
Please insert digit for flange thread			
4-40 UNC ▶ 7 M3 ▶ 9			
Female connector metal shell	9 15 25	09 67 709 . 715 09 67 715 . 715 09 67 725 . 715	
Please insert digit for flange thread			
4-40 UNC ▶ 6 M3 ▶ 8			

D-Sub

<sup>1)</sup> S4: ≥ 0.76 µm Au (30 µinch)

Number of contacts

# 9-25

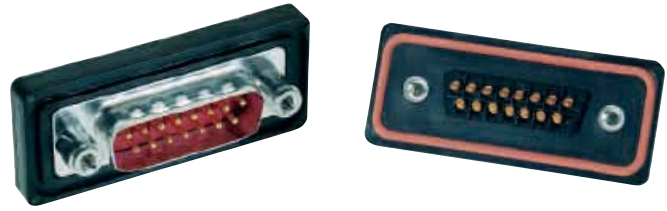

IP 67, turned solder cups, with front plastic mounting plate

Identification

Drawing

Dimensions in mm

**Male connector**  
9 – 25 contacts

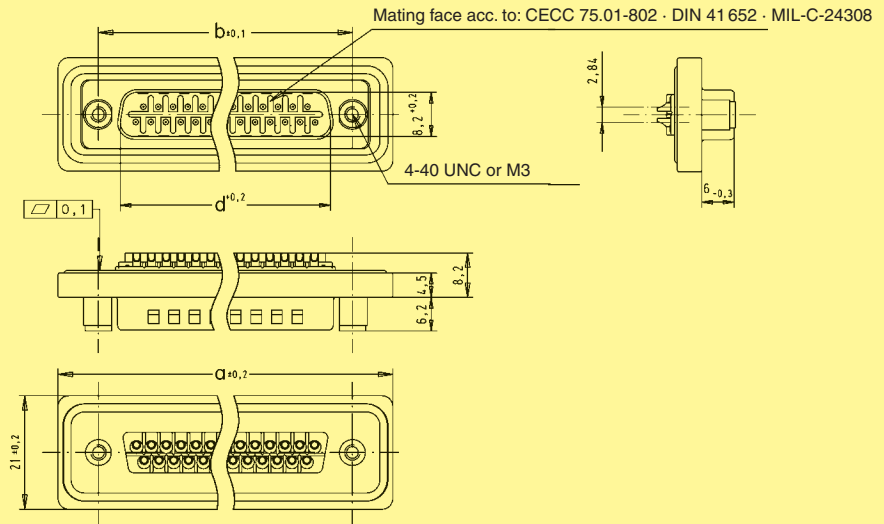

**Female connector**  
9 – 25 contacts

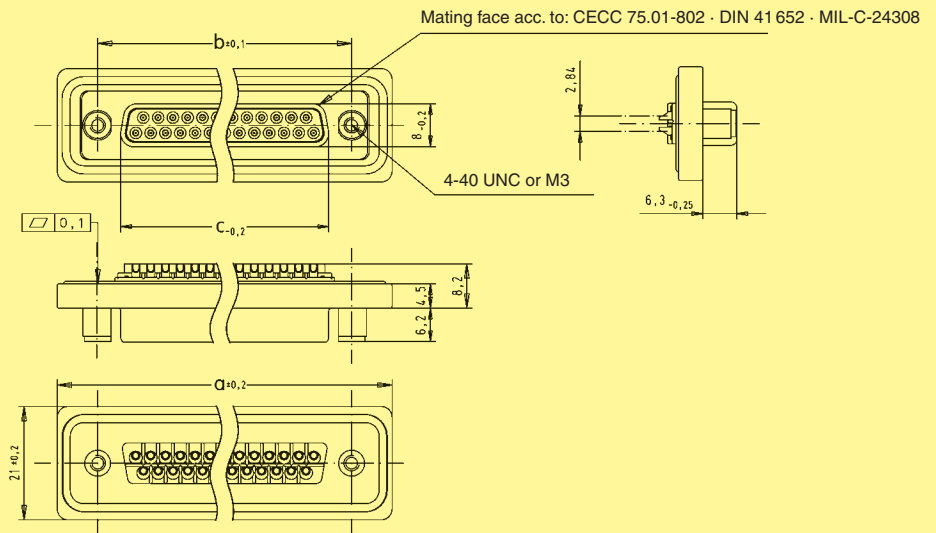

	a	b	c	d
9	40.0	25.00	16.4	16.9
15	48.3	33.30	24.7	25.2
25	62.0	47.04	38.5	38.9

Panel cut out  
for front/rear mount

Values are taken from the  
CECC 75 301-802

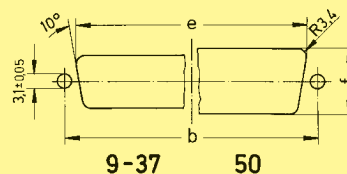

Front mount

Rear mount

	$b_{\pm 0.13}$	$e_{\pm 0.2}$	$f_{\pm 0.2}$
9	25.0	22.2	12.3
15	33.3	30.5	12.3
25	47.0	44.3	12.3

	$b_{\pm 0.13}$	$e_{\pm 0.2}$	$f_{\pm 0.2}$
9	25.0	20.5	11.4
15	33.3	28.8	11.4
25	47.0	42.5	11.4

D-Sub

Number of contacts

9–50



IP 67, turned solder cups, with rear metal mounting plate

Identification	No. of contacts	Part No.	
		S4 <sup>1)</sup>	
Male connector metal shell with dimples			
	9	09 67 609	. 615
	15	09 67 615	. 615
	25	09 67 625	. 615
	37	09 67 637	. 615
	50	09 67 650	. 615
Please insert digit for flange thread			
4-40 UNC ▶	7		
M3 ▶	9		
Female connector metal shell			
	9	09 67 609	. 715
	15	09 67 615	. 715
	25	09 67 625	. 715
	37	09 67 637	. 715
	50	09 67 650	. 715
Please insert digit for flange thread			
4-40 UNC ▶	6		
M3 ▶	8		

D-Sub

<sup>1)</sup> S4: ≥ 0.76 µm Au (30 µinch)

Number of contacts

# 9-50



IP 67, turned solder cups, with rear metal mounting plate

Identification

Drawing

Dimensions in mm

**Male connector**  
9 – 50 contacts

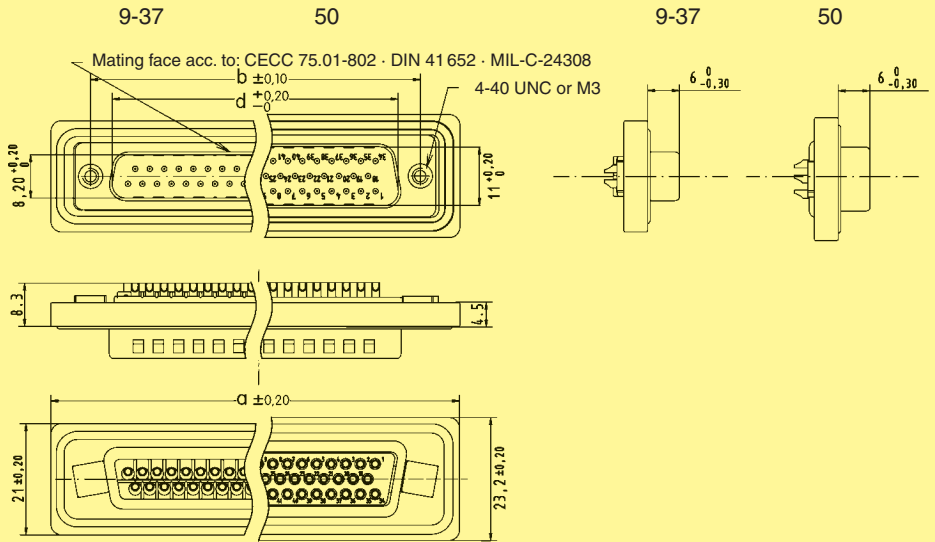

**Female connector**  
9 – 50 contacts

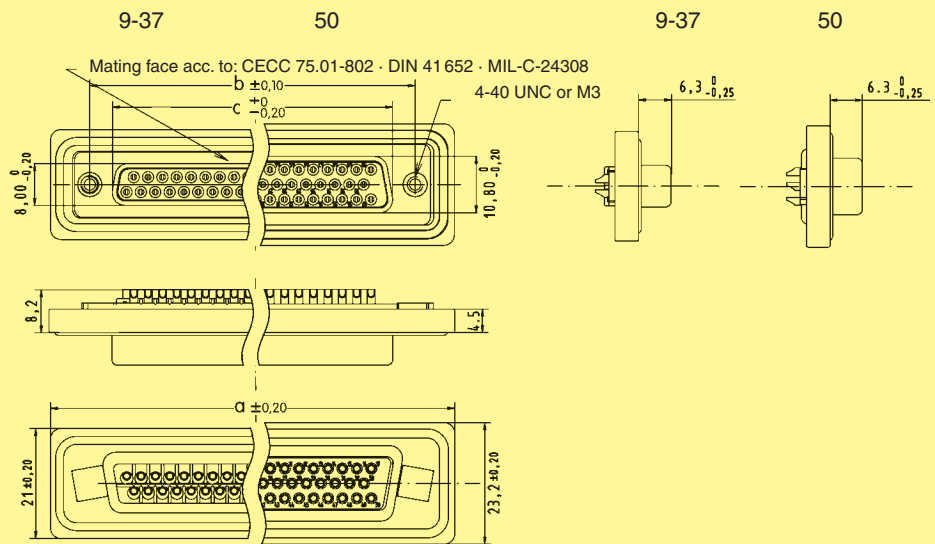

	a	b	c	d
9	40,0	25,00	16,4	16,9
15	48,3	33,30	24,7	25,2
25	62,0	47,04	38,5	38,9
37	78,5	63,50	54,9	55,3
50	76,1	61,10	52,5	52,8

D-Sub

Number of contacts

9–50



IP 67, turned solder cups, with front metal mounting plate

Identification	No. of contacts	Part No.	
		S4 <sup>1)</sup>	
Male connector metal shell with dimples	9 15 25 37 50	09 67 809 09 67 815 09 67 825 09 67 837 09 67 850	. 615 . 615 . 615 . 615 . 615
Please insert digit for flange thread			
4-40 UNC ▶ 7 M3 ▶ 9			
Female connector metal shell	9 15 25 37 50	09 67 809 09 67 815 09 67 825 09 67 837 09 67 850	. 715 . 715 . 715 . 715 . 715
Please insert digit for flange thread			
4-40 UNC ▶ 6 M3 ▶ 8			

D-Sub

<sup>1)</sup> S4: ≥ 0.76 µm Au (30 µinch)

Number of contacts

# 9-50



IP 67, turned solder cups, with front metal mounting plate

Identification

Drawing

Dimensions in mm

**Male connector**  
9 – 50 contacts

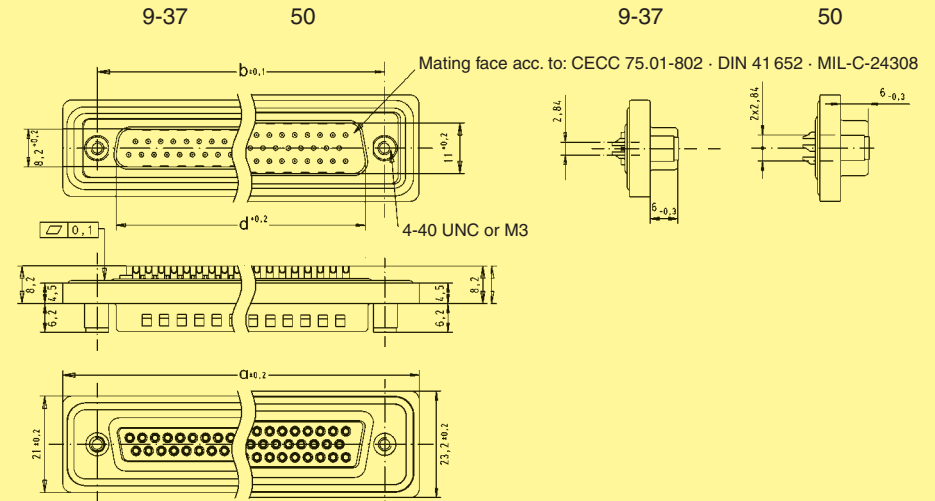

**Female connector**  
9 – 50 contacts

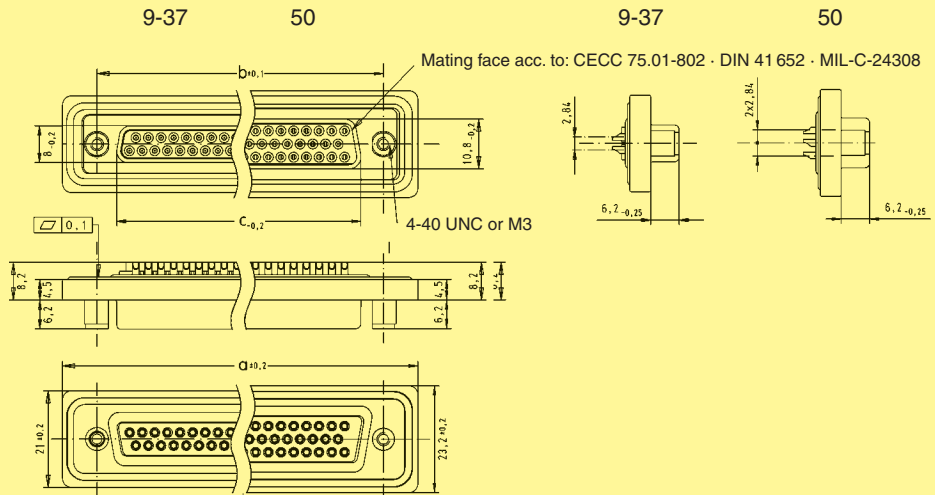

	a	b	c	d
9	40.0	25.00	16.4	16.9
15	48.3	33.30	24.7	25.2
25	62.0	47.04	38.5	38.9
37	78.5	63.50	54.9	55.3
50	76.1	61.10	51.3	52.8

Panel cut out  
for front/rear mount

Values are taken from the  
CECC 75 301-802

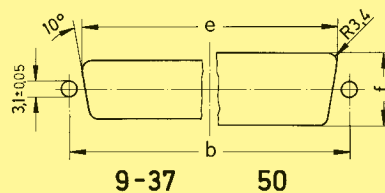

Front mount

Rear mount

	$b_{\pm 0.13}$	$e_{\pm 0.2}$	$f_{\pm 0.2}$
9	25.0	22.2	12.3
15	33.3	30.5	12.3
25	47.0	44.3	12.3
37	63.5	60.7	12.3
50	61.1	58.3	15.1

	$b_{\pm 0.13}$	$e_{\pm 0.2}$	$f_{\pm 0.2}$
9	25.0	20.5	11.4
15	33.3	28.8	11.4
25	47.0	42.5	11.4
37	63.5	59.1	11.4
50	61.1	56.3	14.1

D-Sub

Number of contacts

9-25



IP 67, straight turned solder pins,  
with rear plastic mounting plate, spacer and board lock

Identification	No. of contacts	Part No.	
		S4 <sup>1)</sup>	
<b>Male connector</b> metal shell with dimples	9 15 25	09 67 509 . 675 09 67 515 . 675 09 67 525 . 675	
Please insert digit for flange thread			
4-40 UNC ▶ 7 M3 ▶ 9			
<b>Female connector</b> metal shell	9 15 25	09 67 509 . 775 09 67 515 . 775 09 67 525 . 775	
Please insert digit for flange thread			
4-40 UNC ▶ 6 M3 ▶ 8			

D-Sub

<sup>1)</sup> S4: ≥ 0.76 µm Au (30 µinch)

Number of contacts

# 9-25



IP 67, straight turned solder pins, with rear plastic mounting plate, spacer and board lock

Identification

Drawing

Dimensions in mm

**Male connector**  
9 – 25 contacts

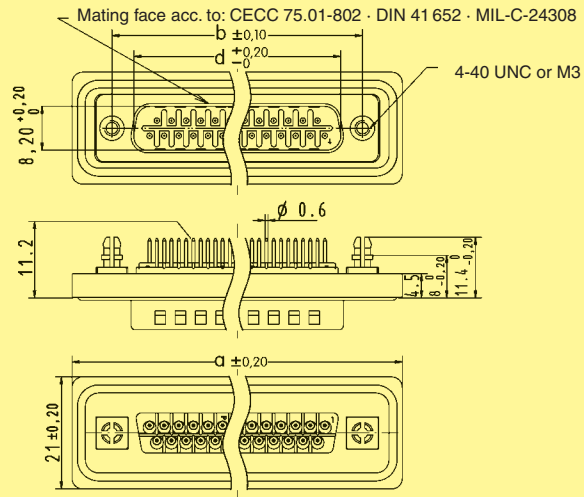

**Female connector**  
9 – 25 contacts

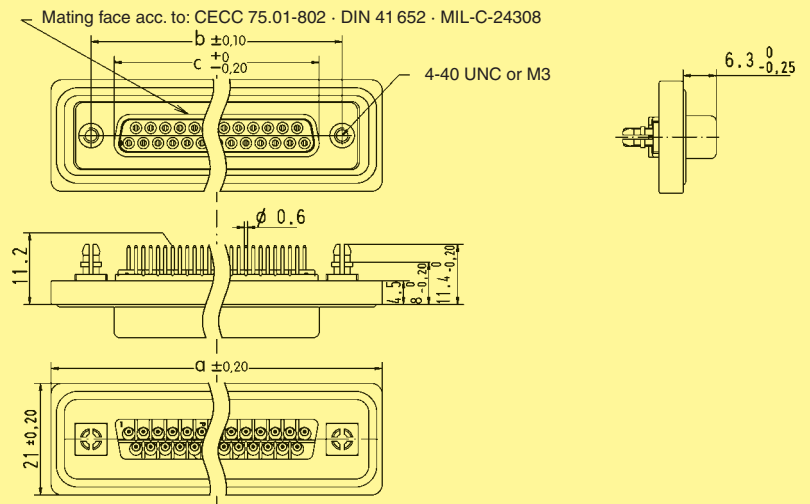

	a	b	c	d	g	h	i
9	40.0	25.00	16.4	16.9	4 x 2.74 = 10.96	3 x 2.74 = 8.22	25.0
15	48.3	33.30	24.7	25.2	7 x 2.74 = 19.18	6 x 2.74 = 16.44	33.3
25	62.0	47.04	38.5	38.9	12 x 2.76 = 33.12	11 x 2.76 = 30.36	47.0

Board drillings

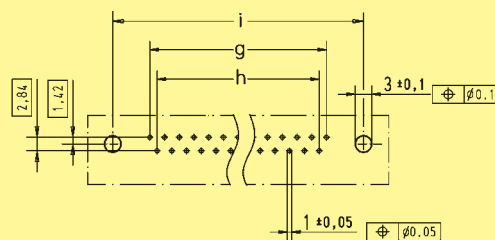



Number of contacts

9–50



IP 67, straight turned solder pins,  
with rear metal mounting plate, spacer and board lock

Identification	No. of contacts	Part No.	
		S4 <sup>1)</sup>	
<b>Male connector</b> metal shell with dimples	9 15 25 37 50	09 67 609 09 67 615 09 67 625 09 67 637 09 67 650	. 675 . 675 . 675 . 675 . 675
Please insert digit for flange thread	4-40 UNC ▶ 7 M3 ▶ 9		
<b>Female connector</b> metal shell	9 15 25 37 50	09 67 609 09 67 615 09 67 625 09 67 637 09 67 650	. 775 . 775 . 775 . 775 . 775
Please insert digit for flange thread	4-40 UNC ▶ 6 M3 ▶ 8		

D-Sub

<sup>1)</sup> S4: ≥ 0.76 µm Au (30 µinch)

Number of contacts

# 9-50



IP 67, straight turned solder pins, with rear metal mounting plate, spacer and board lock

Identification

Drawing

Dimensions in mm

**Male connector**  
9 – 50 contacts

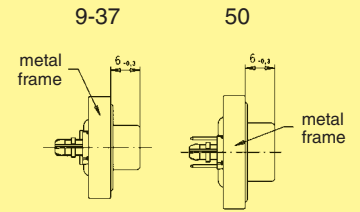
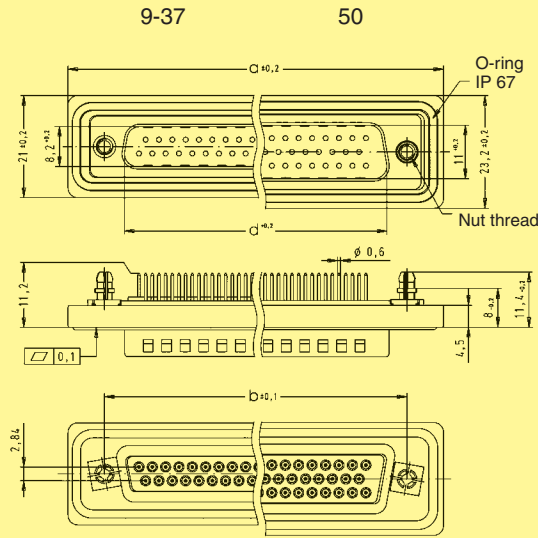

**Female connector**  
9 – 50 contacts

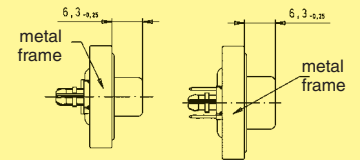
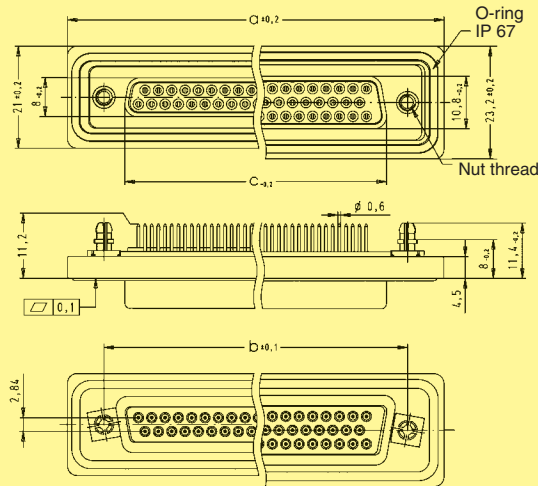

	a	b	c	d	g	h
9	40.0	25.00	16.4	16.9	4 x 2.74 = 10.96	3 x 2.74 = 8.22
15	48.3	33.30	24.7	25.2	7 x 2.74 = 19.18	6 x 2.74 = 16.44
25	62.0	47.04	38.5	38.9	12 x 2.76 = 33.12	11 x 2.76 = 30.36
37	78.5	63.50	54.9	55.3	18 x 2.76 = 49.68	17 x 2.76 = 46.92
50	76.1	61.10	52.5	52.8	16 x 2.76 = 44.16	15 x 2.76 = 41.40

Board drillings

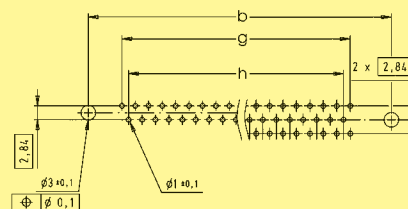

Number of contacts

9-25



IP 67, angled turned solder pins,  
with rear plastic mounting plate, bracket and board lock

Identification	No. of contacts	Part No.	
		S4 <sup>1)</sup>	
<b>Male connector</b> metal shell with dimples	9 15 25	09 67 509 . 658 09 67 515 . 658 09 67 525 . 658	
Please insert digit for flange thread			
4-40 UNC ▶ 7 M3 ▶ 9			
<b>Female connector</b> metal shell	9 15 25	09 67 509 . 758 09 67 515 . 758 09 67 525 . 758	
Please insert digit for flange thread			
4-40 UNC ▶ 6 M3 ▶ 8			

D-Sub

<sup>1)</sup> S4: ≥ 0.76 µm Au (30 µinch)

Number of contacts

# 9-25



IP 67, angled turned solder pins,  
with rear plastic mounting plate, bracket and board lock

Identification

Drawing

Dimensions in mm

**Male connector**  
9 – 25 contacts

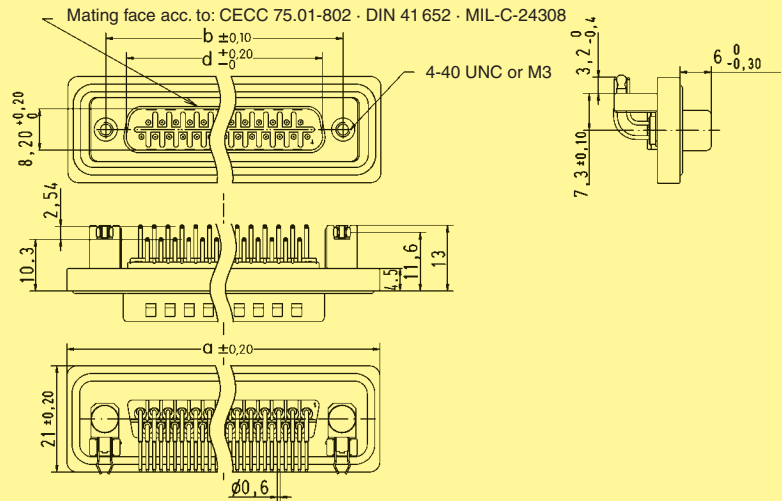

**Female connector**  
9 – 25 contacts

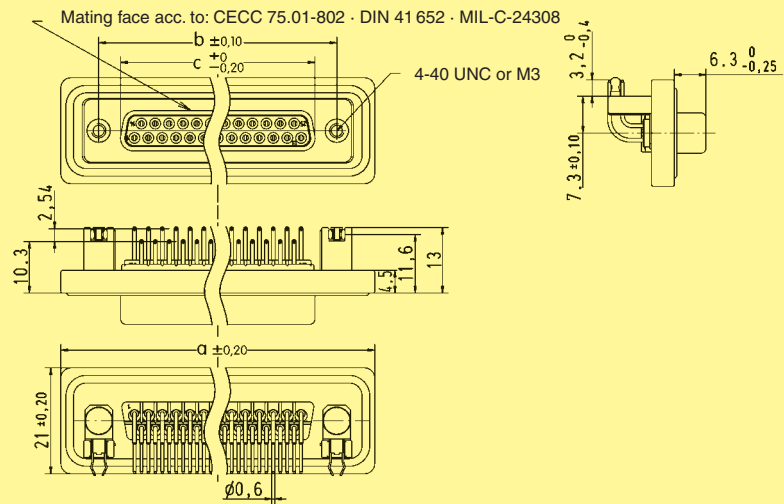

	a	b	c	d	g	h	i
9	40.0	25.00	16.4	16.9	4 x 2.74 = 10.96	3 x 2.74 = 8.22	25.0
15	48.3	33.30	24.7	25.2	7 x 2.74 = 19.18	6 x 2.74 = 16.44	33.3
25	62.0	47.04	38.5	38.9	12 x 2.76 = 33.12	11 x 2.76 = 30.36	47.0

Board drillings

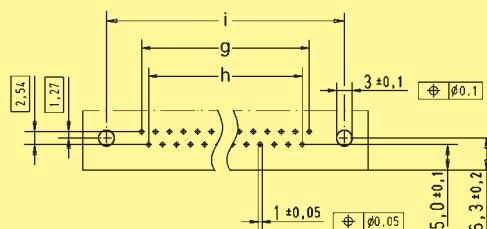

Number of contacts

# 9–50

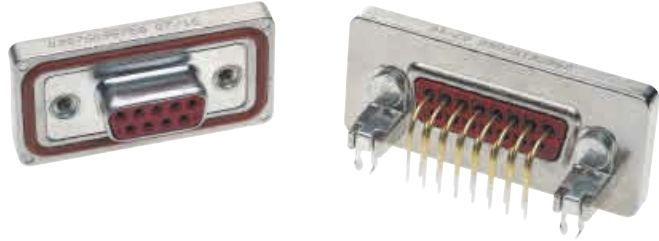

IP 67, angled turned solder pins,  
with rear metal mounting plate, bracket and board lock

Identification	No. of contacts	Part No.	
		S4 <sup>1)</sup>	
<b>Male connector</b> metal shell with dimples  Please insert digit for flange thread  4-40 UNC ▶ 7 M3 ▶ 9	9	09 67 609	658
	15	09 67 615	658
	25	09 67 625	658
	37	09 67 637	658
	50	09 67 650	658
<b>Female connector</b> metal shell  Please insert digit for flange thread  4-40 UNC ▶ 6 M3 ▶ 8	9	09 67 609	758
	15	09 67 615	758
	25	09 67 625	758
	37	09 67 637	758
	50	09 67 650	758

D-Sub

<sup>1)</sup> S4: ≥ 0.76 µm Au (30 µinch)

Number of contacts

# 9-50

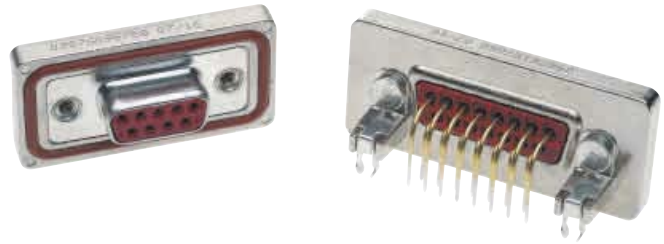

IP 67, angled turned solder pins,  
with rear metal mounting plate, bracket and board lock

Identification

Drawing

Dimensions in mm

**Male connector**  
9 – 50 contacts

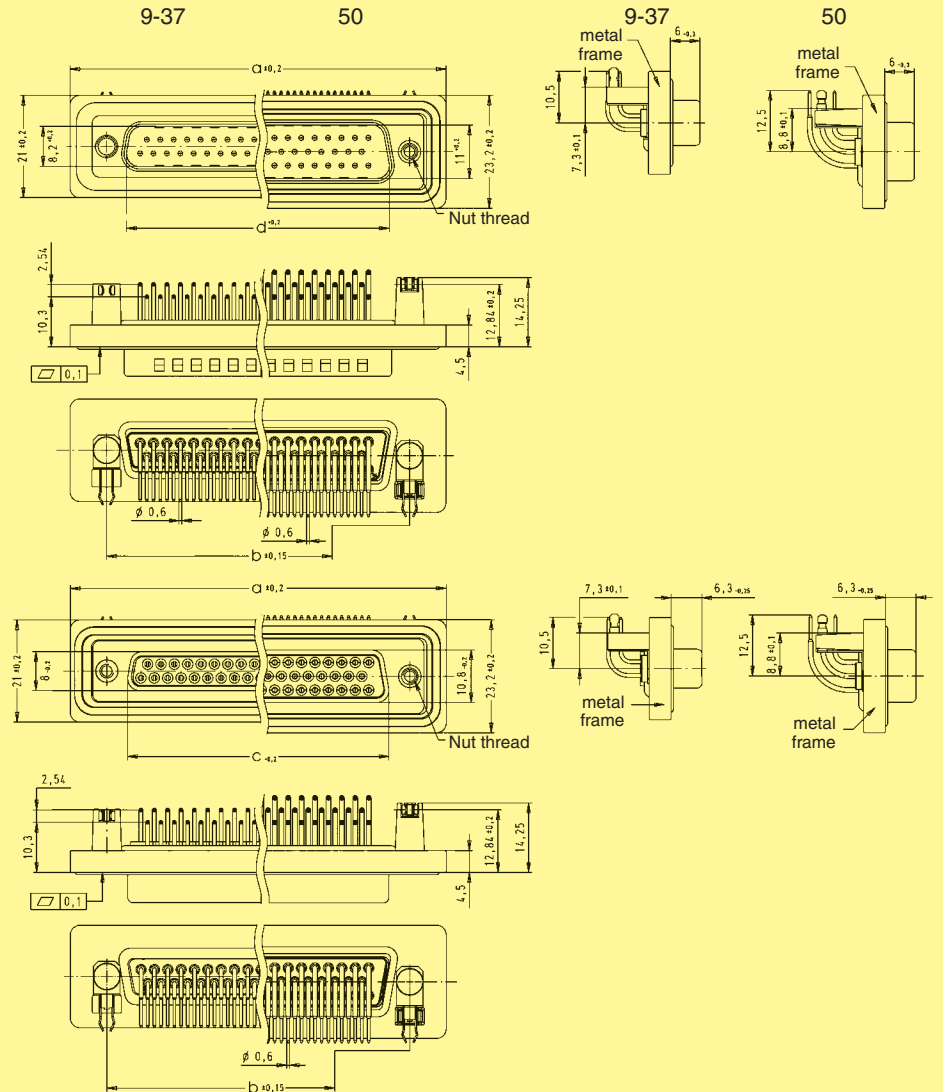



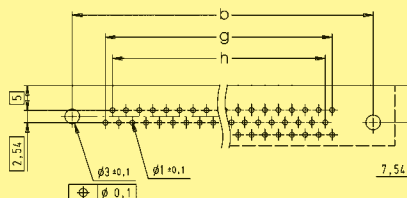

**Female connector**  
9 – 50 contacts

	a	b	c	d	g	h
9	40.0	25.00	16.4	16.9	4 x $2.74 = 10.96$	3 x $2.74 = 8.22$
15	48.3	33.30	24.7	25.2	7 x $2.74 = 19.18$	6 x $2.74 = 16.44$
25	62.0	47.04	38.5	38.9	12 x $2.76 = 33.12$	11 x $2.76 = 30.36$
37	78.5	63.50	54.9	55.3	18 x $2.76 = 49.68$	17 x $2.76 = 46.92$
50	76.1	61.10	52.5	52.8	16 x $2.76 = 44.16$	15 x $2.76 = 41.40$

Board drillings

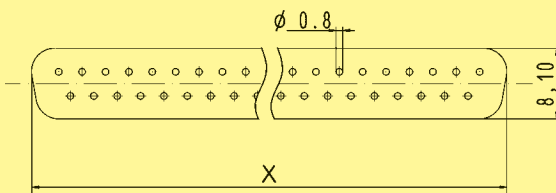
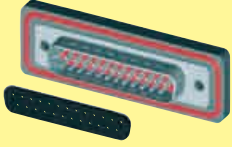
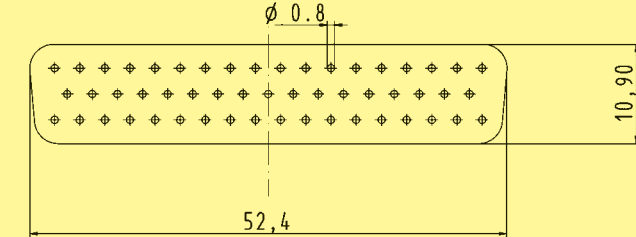

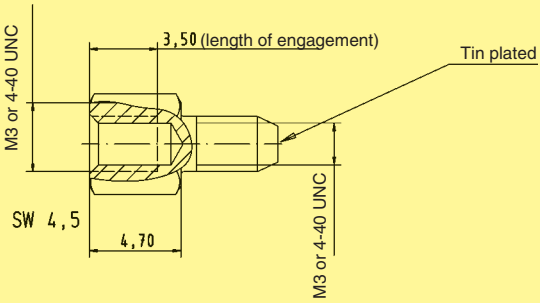
## Accessories for IP 67 connectors

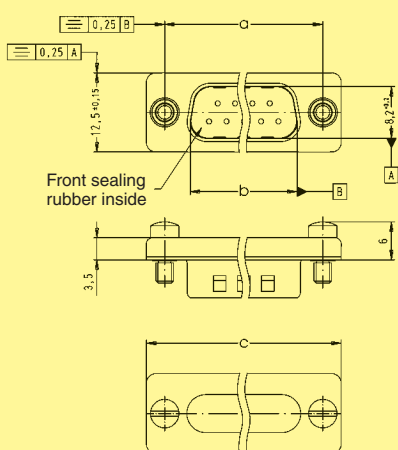
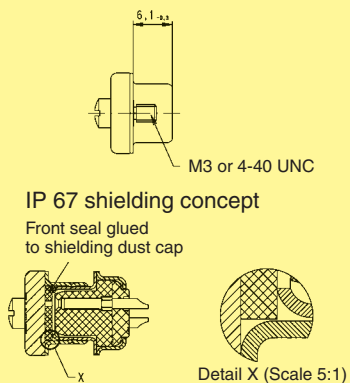
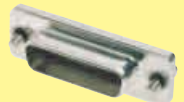
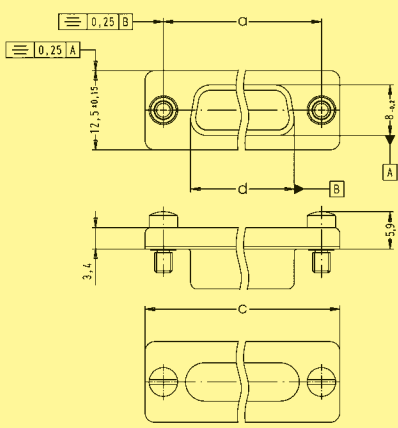
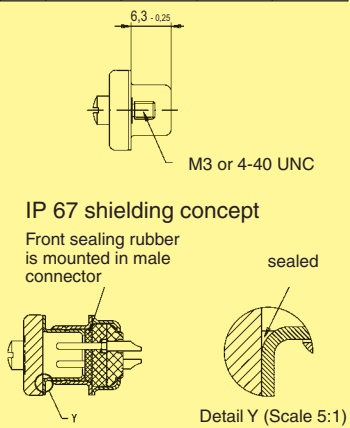
Identification	No. of contacts	Part No.	Drawing	Dimensions in mm																				
<b>Front sealing rubber<sup>1)</sup></b> IP 67 	9	09 67 002 9001		<table border="1"> <thead> <tr> <th></th> <th>x</th> </tr> </thead> <tbody> <tr> <td>9</td> <td>16.7</td> </tr> <tr> <td>15</td> <td>24.8</td> </tr> <tr> <td>25</td> <td>38.8</td> </tr> <tr> <td>37</td> <td>54.7</td> </tr> </tbody> </table>		x	9	16.7	15	24.8	25	38.8	37	54.7										
		x																						
	9	16.7																						
	15	24.8																						
25	38.8																							
37	54.7																							
15	09 67 002 9002																							
25	09 67 002 9003																							
37	09 67 002 9004																							
<b>Mounting example</b> 	50	09 67 002 9005																						
<b>Female screw lock and spacing washer</b> M3 		09 67 002 9006																						
	4-40 UNC	09 67 002 9007																						
<b>Dust cap for female connectors<sup>2)</sup></b> M3 	9	09 67 002 9055	 <p><b>IP 67 shielding concept</b> Front seal glued to shielding dust cap</p>  <table border="1"> <thead> <tr> <th></th> <th>a</th> <th>b</th> <th>c</th> <th>d</th> </tr> </thead> <tbody> <tr> <td>9</td> <td>25.00</td> <td>16.9</td> <td>30.8</td> <td>16.4</td> </tr> <tr> <td>15</td> <td>33.30</td> <td>25.2</td> <td>39.1</td> <td>24.7</td> </tr> <tr> <td>25</td> <td>47.04</td> <td>38.9</td> <td>53.0</td> <td>38.5</td> </tr> </tbody> </table>		a	b	c	d	9	25.00	16.9	30.8	16.4	15	33.30	25.2	39.1	24.7	25	47.04	38.9	53.0	38.5	
		a		b	c	d																		
	9	25.00		16.9	30.8	16.4																		
	15	33.30		25.2	39.1	24.7																		
	25	47.04		38.9	53.0	38.5																		
	15	09 67 002 9056																						
25	09 67 002 9057																							
4-40 UNC	9	09 67 002 9050																						
	15	09 67 002 9051																						
	25	09 67 002 9052																						
<sup>2)</sup> With inside glued front sealing rubber for male connectors <sup>3)</sup> M3 	9	09 67 002 9065	 <p><b>IP 67 shielding concept</b> Front sealing rubber is mounted in male connector</p> 																					
	15	09 67 002 9066																						
	25	09 67 002 9067																						
	4-40 UNC	9		09 67 002 9060																				
		15		09 67 002 9061																				
		25		09 67 002 9062																				

<sup>1)</sup> The front sealing rubber is necessary when a mated system needs to have the IP 67 performance; in this case, the front sealing rubber is positioned in the IP 67 male connector prior to the mating operation with the facing IP 67 connector; it provides a full protection of the contacts at the mated area by preventing possible ingress of liquids or dust between the shells.



IP 67 plastic hoods

Identification	No. of contacts	Part No.	Drawing	Dimensions in mm
----------------	-----------------	----------	---------	------------------

Hood  
Black thermoplastic

9	09 67 009 0436
15	09 67 015 0436
25	09 67 025 0436

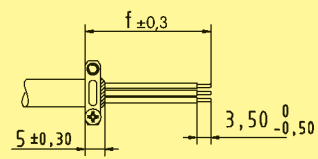
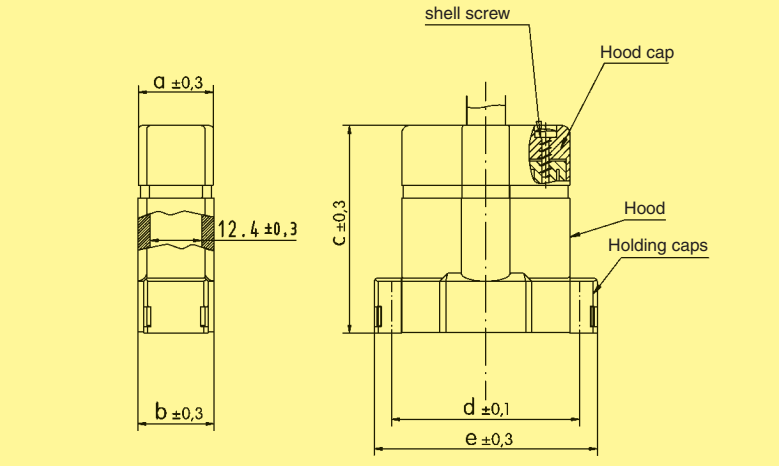

**Mounting instructions**  
The stripped braid should not be fold back to avoid damaging the cable clamp and reducing its performance.

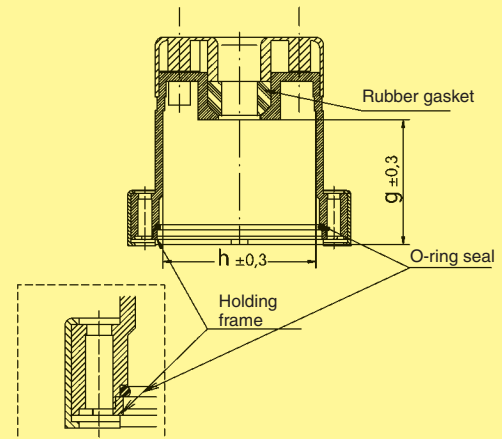
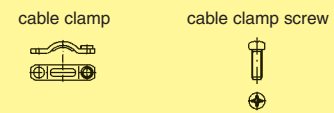

	a	b	c	d	e	f	g	h
9	15.6	15.6	41.0	25.00	33.6	23.0	25.0	17.0
15	15.6	15.6	46.8	33.30	42.0	27.5	30.8	25.1
25	18.8	19.1	52.0	47.04	55.7	31.5	33.8	38.8

D-Sub





IP 67 metallized plastic hoods

Identification      No. of contacts      Part No.      Drawing      Dimensions in mm

Hood  
Metallized  
thermoplastic

9	09 67 009 0437
15	09 67 015 0437
25	09 67 025 0437

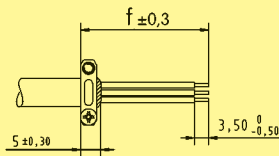
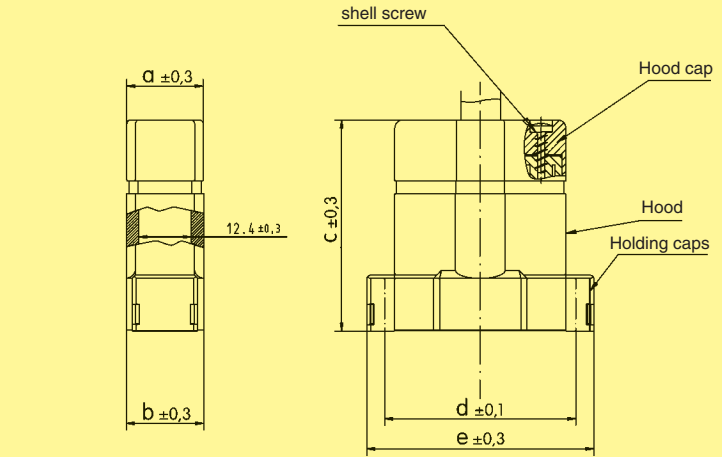

Mounting instructions



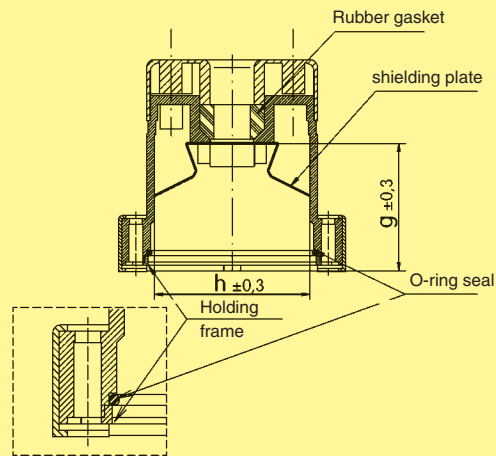
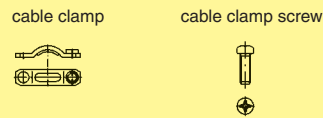





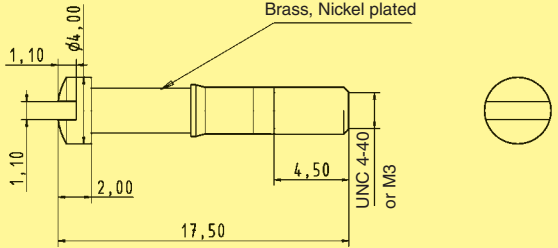

The stripped braid should not be fold back to avoid damaging the cable clamp and reducing its performance.

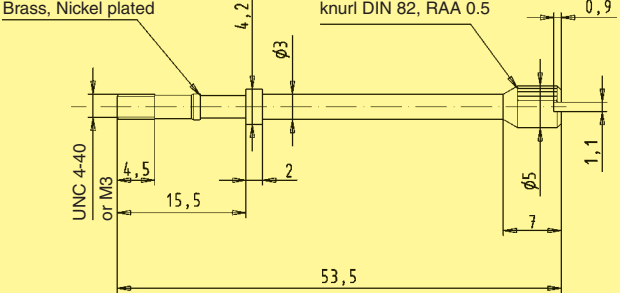

	a	b	c	d	e	f	g	h
9	15.6	15.6	41.0	25.00	33.6	23.0	25.0	17.0
15	15.6	15.6	46.8	33.30	42.0	27.5	30.8	25.1
25	18.8	19.1	52.0	47.04	55.7	31.5	33.8	38.8

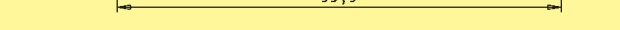
D-Sub

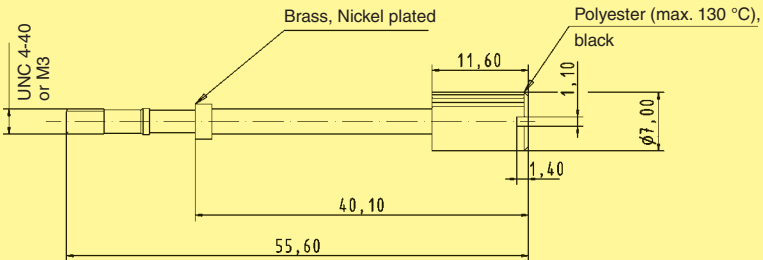
Accessories for IP 67 hoods

Identification	No. of contacts	Part No.	Drawing	Dimensions in mm
<p>Short locking screw 4-40 UNC</p> 		09 67 002 9008		
<p>Short locking screw M3</p> 		09 67 002 9009		
<p>Knurled locking screw 4-40 UNC</p> 		09 67 002 9010		
<p>Knurled locking screw M3</p> 		09 67 002 9011		
<p>Knurled locking screw 4-40 UNC with plastic cap</p> 		09 67 002 9012		
<p>Knurled locking screw M3 with plastic cap</p> 		09 67 002 9013		

D-Sub

## HARTING – Guarantee a secure connection

Modern electronic applications demand a high degree of mechanical and electrical security.

To meet these requirements, continuous screening from the cable to the PCB via the connector is achieved by using state of the art components to DIN 41 652.

HARTING offer many solutions. These utilise various combinations of male and female connectors with hoods, featuring either screw locking or latching facilities.

Only 2 examples are shown:

- Continuous security screening and grounding with screw locking and metallized hood.
- Continuous grounding and vibration proof latching system with metallized hood.

D-Sub

Male connector with dimples

Screw lock

Cable with protective screen

Strain relief

Metallized hood

Female connector with protective metal shell

Grounding contact between protective metal shell and PCB

Female connector with protective metal shell

Spring latch

Strain relief

Cable with protective screen

Metallized hood

Male connector with dimples

Connector hoods for screw locking

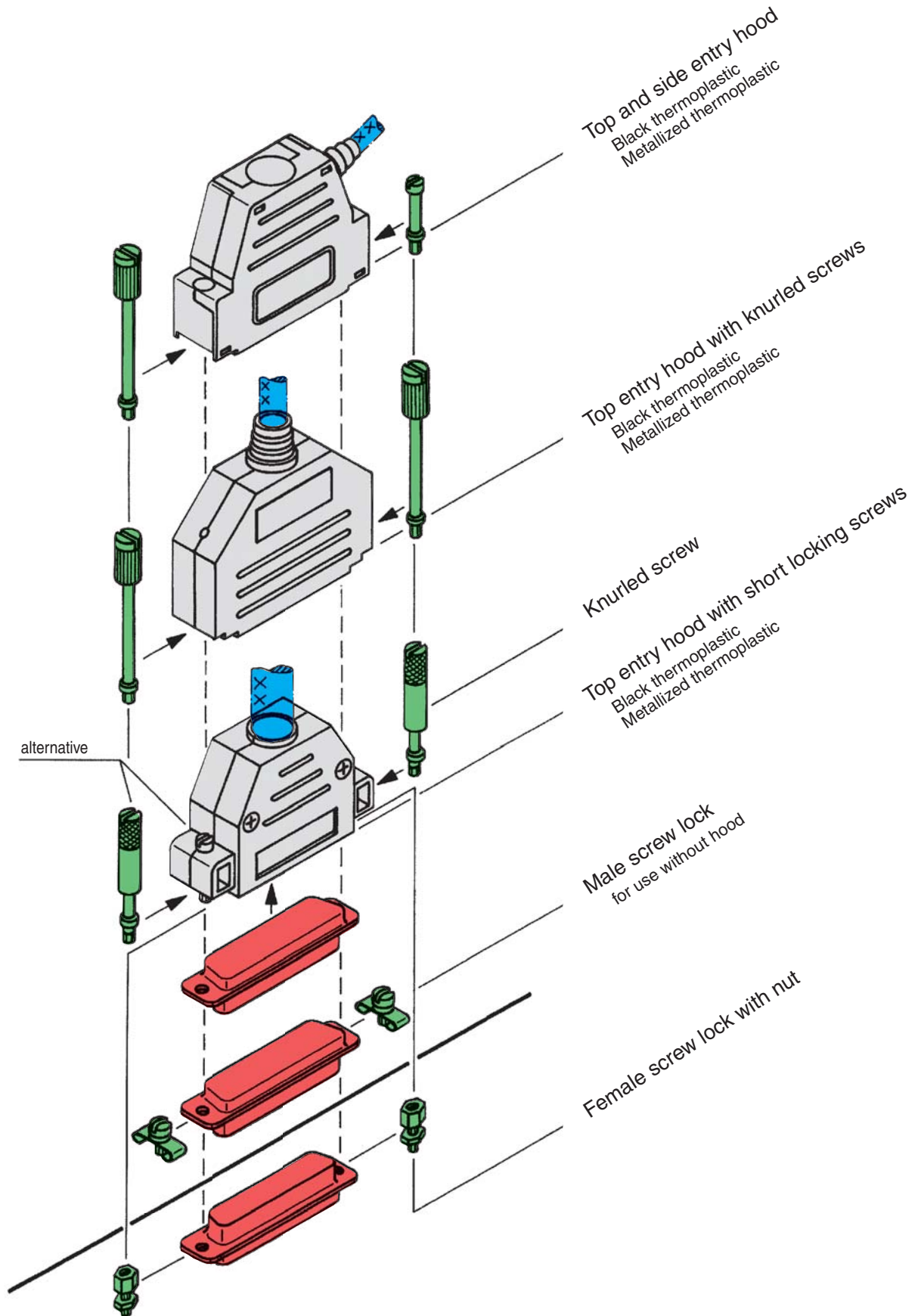

D-Sub



Top and side entry hoods with knurled screws

Identification	No. of contacts	Part No.	Drawing	Dimensions in mm																																																
<b>Top entry hood</b> Black thermoplastic	9 15 25 37 50	09 67 009 0424 09 67 015 0424 09 67 025 0424 09 67 037 0424 09 67 050 0424		<table border="1"> <thead> <tr> <th></th> <th>A1</th> <th>A2</th> <th>B</th> <th>C1</th> <th>C2</th> <th>max. Ø 1</th> <th>max. Ø 2</th> </tr> </thead> <tbody> <tr> <td>9</td> <td>31.5</td> <td>32.5</td> <td>15</td> <td>34</td> <td>38</td> <td>8.0</td> <td>11.5</td> </tr> <tr> <td>15</td> <td>40.0</td> <td>41.0</td> <td>15</td> <td>34</td> <td>38</td> <td>11.5</td> <td>11.5</td> </tr> <tr> <td>25</td> <td>53.5</td> <td>54.5</td> <td>15</td> <td>40</td> <td>40</td> <td>11.5</td> <td>11.5</td> </tr> <tr> <td>37</td> <td>71.0</td> <td>71.0</td> <td>15</td> <td>40</td> <td>40</td> <td>11.5</td> <td>11.5</td> </tr> <tr> <td>50</td> <td>67.5</td> <td></td> <td>19</td> <td>40</td> <td></td> <td>14.0</td> <td></td> </tr> </tbody> </table> <p>C1: non-metallized      C2: metallized</p>		A1	A2	B	C1	C2	max. Ø 1	max. Ø 2	9	31.5	32.5	15	34	38	8.0	11.5	15	40.0	41.0	15	34	38	11.5	11.5	25	53.5	54.5	15	40	40	11.5	11.5	37	71.0	71.0	15	40	40	11.5	11.5	50	67.5		19	40		14.0	
	A1	A2	B	C1	C2	max. Ø 1	max. Ø 2																																													
9	31.5	32.5	15	34	38	8.0	11.5																																													
15	40.0	41.0	15	34	38	11.5	11.5																																													
25	53.5	54.5	15	40	40	11.5	11.5																																													
37	71.0	71.0	15	40	40	11.5	11.5																																													
50	67.5		19	40		14.0																																														
<b>Top entry hood</b> Metallized thermoplastic	9 15 25 37	09 67 009 0425 09 67 015 0425 09 67 025 0425 09 67 037 0425		<p>Cut appropriate cable entry to fit actual cable diameter</p>																																																
<b>Top and side entry hood</b> Black thermoplastic	9 15 25 37	09 67 009 0434 09 67 015 0434 09 67 025 0434 09 67 037 0434 <sup>1)</sup>		<table border="1"> <thead> <tr> <th></th> <th>A</th> <th>B</th> <th>C</th> </tr> </thead> <tbody> <tr> <td>9</td> <td>31.5</td> <td>15</td> <td>40.0</td> </tr> <tr> <td>15</td> <td>40.0</td> <td>15</td> <td>40.0</td> </tr> <tr> <td>25</td> <td>53.5</td> <td>15</td> <td>43.0</td> </tr> <tr> <td>37</td> <td>71.3</td> <td>15</td> <td>42.5</td> </tr> </tbody> </table>		A	B	C	9	31.5	15	40.0	15	40.0	15	40.0	25	53.5	15	43.0	37	71.3	15	42.5																												
	A	B	C																																																	
9	31.5	15	40.0																																																	
15	40.0	15	40.0																																																	
25	53.5	15	43.0																																																	
37	71.3	15	42.5																																																	
<b>Top and side entry hood</b> Metallized thermoplastic	9 15 25 37	09 67 009 0435 09 67 015 0435 <sup>2)</sup> 09 67 025 0435 <sup>2)</sup> 09 67 037 0435 <sup>1)</sup>																																																		
<b>Grommet</b> for top and side entry black thermoplastic hood		09 67 001 9968																																																		

D-Sub

<sup>1)</sup> 37 ways is only side entry  
<sup>2)</sup> Cable clamp kit for two outputs is available with Part No. 09 67 001 9988 (it includes: screw, metal clamp, plastic insert and grommet)



Side entry hoods with knurled screws

Identification      No. of contacts      Part No.      Drawing      Dimensions in mm

Hood <sup>1)</sup> grey thermoplastic RAL 7032	9	09 67 009 0571
	15	09 67 015 0571
	25	09 67 025 0571
	37	09 67 037 0571
	50	09 67 050 0571
grey thermoplastic with internal tin-plate screening	9	09 67 009 0573
	15	09 67 015 0573
	25	09 67 025 0573
	37	09 67 037 0573
	50	09 67 050 0573
9-37 way for packaging density of 3 TE (15.24 mm)		

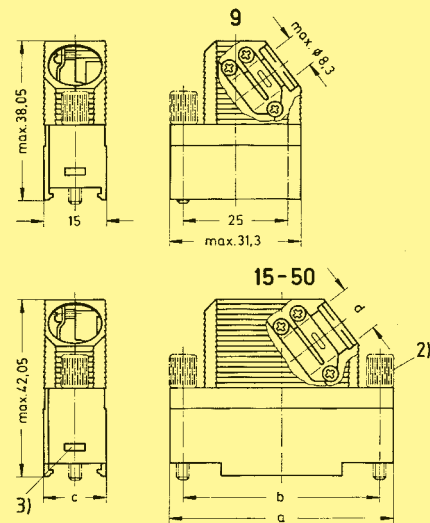

	a max.	b	c	d max.
15	39.62	33.3	15	Ø 9.1
25	53.52	47.0	15	Ø 11.5
37	69.80	63.5	15	Ø 12.8
50	67.41	61.1	19	Ø 14.5

Knurled screw Thread UNC Thread M3	9-50	09 67 000 9971 <sup>4)</sup>
		09 67 001 9965*
Thread UNC Thread M3	9-50	09 67 001 9978
		09 67 001 9977

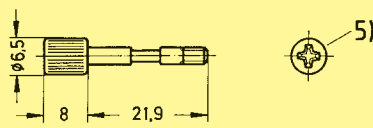

Grey head / Nickel plated steel

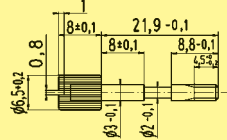

Full metal part

Tooling <sup>6)</sup> for assembly of hoods		
	Top part	09 99 000 0215*
Bottom part	09 99 000 0216*	



\* Not normally kept in stock  
<sup>1)</sup> Order knurled screw separately  
<sup>2)</sup> Before assembling the hood, the knurled screws must be inserted into the lower hood part.  
<sup>3)</sup> For retained nut when using slide lock or female screw lock  
<sup>4)</sup> 9 way 1 per hood – 15-50 way 2 per hood  
<sup>5)</sup> Screw driver type ISO PH 1 for philips screw No 1 ISO norm 4757  
<sup>6)</sup> Additional tooling (bench press) see chapter 32

D-Sub

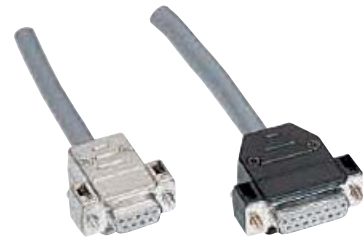

Top entry hoods with knurled or locking screws

Identification      No. of contacts      Part No.      Drawing      Dimensions in mm

**Hood**  
Black thermoplastic with short locking screws

9	09 67 009 0442
15	09 67 015 0442
25	09 67 025 0442
37	09 67 037 0442
50	09 67 050 0442

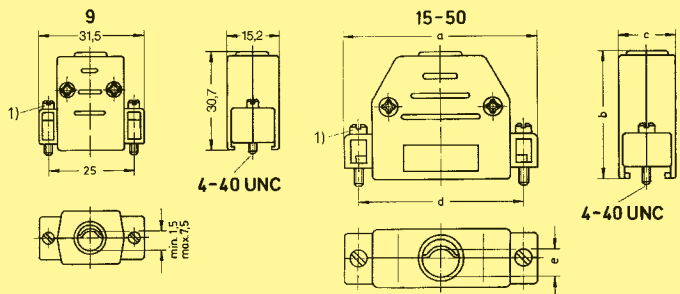

**Hood**  
Metallized thermoplastic with short locking screws

9	09 67 009 0443
15	09 67 015 0443
25	09 67 025 0443
37	09 67 037 0443
50	09 67 050 0443

	a	b	c	d	e	
					min.	max.
15	40.0	34.7	15.2	33.3	3.3	8.5
25	53.2	39.7	15.2	47.0	3.5	11.0
37	70.0	39.7	15.2	63.5	3.5	11.0
50	67.5	39.7	18.2	61.1	9.3	12.0

**Knurled screw**  
for metallized hood  
Thread UNC  
Thread M3

9-50	09 67 000 9925 <sup>2)</sup>
9-50	09 67 000 9930 <sup>2)</sup>

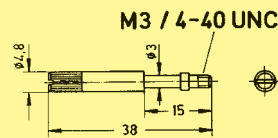

<sup>1)</sup> Use of knurled screws is possible. Please order separately  
<sup>2)</sup> Order 2 for each hood



## Full metal top and side entry hoods with knurled screws

Identification      No. of contacts      Part No.      Drawing      Dimensions in mm

### Top entry hood

	9	09 67 009 034 .
	15	09 67 015 034 .
	25	09 67 025 034 .
	37	09 67 037 034 .

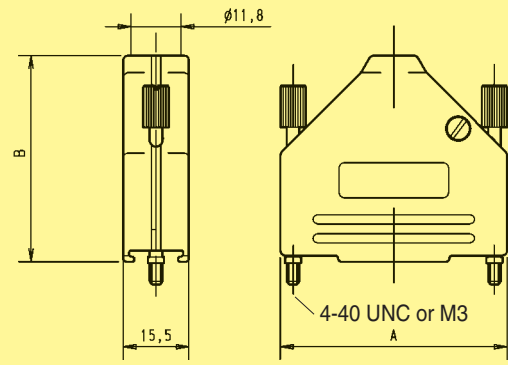

Poles	A	B
9	31.2	39.9
15	39.5	41.5
25	53.4	48.6
37	69.7	53.6

Please insert digit for screw option

- Knurled screw, thread 4-40 UNC ▶ 3
- Knurled screw, thread M3 ▶ 8

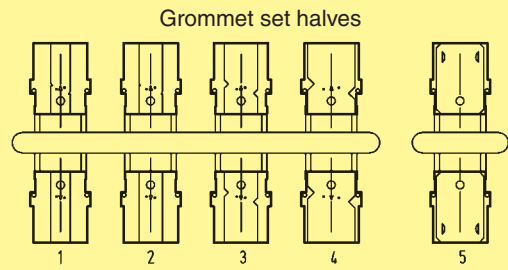

Grommet dimensions	
Number	Diameter
1	4.0
2	5.0
3	7.0
4	10.0
5	10.2

### Side entry hood

	9 <sup>1)</sup>	09 67 009 033 .
	15	09 67 015 033 .
	25	09 67 025 033 .
	37	09 67 037 033 .

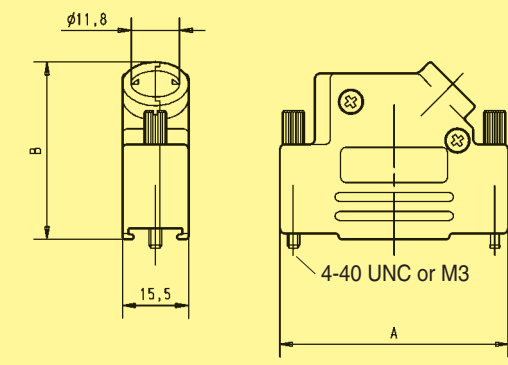

Poles	A	B
9	31.0	38.0
15	40.5	41.1
25	53.7	41.8
37	69.8	41.8

Please insert digit for screw option

- Knurled screw, thread 4-40 UNC ▶ 3
- Knurled screw, thread M3 ▶ 6

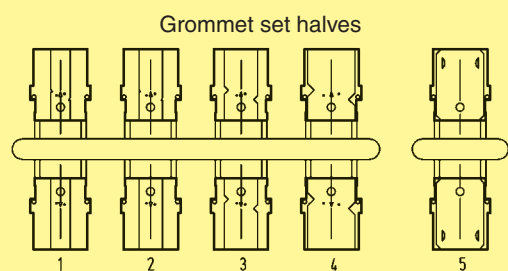

Grommet dimensions	
Number	Diameter
1	4.0
2	5.0
3	7.0
4	10.0
5	10.2

<sup>1)</sup> 9 pole hood provided with only one screw on the opposite side of the cable entry.





Full metal top and side entry hoods with short screws

Identification      No. of contacts      Part No.      Drawing      Dimensions in mm

### Top entry hood

9	09 67 009 034
15	09 67 015 034
25	09 67 025 034
37	09 67 037 034
50	09 67 050 034

Please insert digit for screw option

- Locking screw, thread 4-40 UNC ▶ 4
- Locking screw, thread M3 ▶ 9

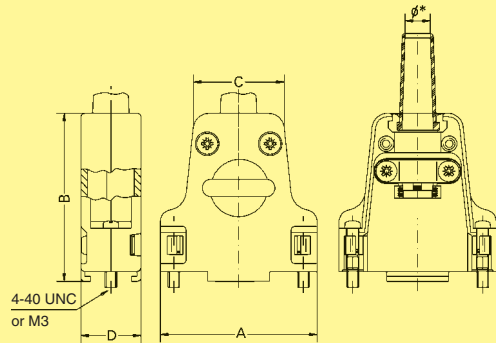

Poles	A	B	C	D	Ø F1		Ø F2	Ø F3
					Min.	Max.		
9	31.8	42.4	20.8	15.4	3.0	9.5	6.5	–
15	40.3	43.5	23.3	15.4	3.0	8.5	6.5	12.5
25	54.0	47.7	31.7	15.4	3.0	8.5	8.0	12.5
37	70.2	50.4	48.2	18.4	3.0	12.0	9.0	15.0
50	67.8	50.5	45.8	18.2	3.0	12.0	9.7	15.0

\* Cable diameter without rubber bushing = Ø F1  
 Cable diameter with rubber bushing = Ø F2  
 Cable diameter without rubber bushing and without cable reduction plate = Ø F3

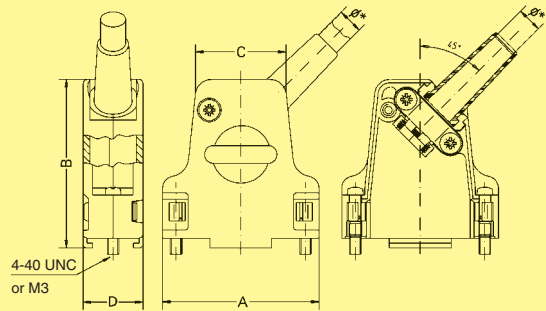

### Side entry hood

9	09 67 009 033
15	09 67 015 033
25	09 67 025 033
37	09 67 037 033
50	09 67 050 033

Please insert digit for screw option

- Locking screw, thread 4-40 UNC ▶ 4
- Locking screw, thread M3 ▶ 5

D-Sub



Full metal top entry hoods  
with premounted threaded inserts

Identification      No. of contacts      Part No.      Drawing      Dimensions in mm

### Top entry hood

9	09 67 009 032
15	09 67 015 032
25	09 67 025 032
37	09 67 037 032
50	09 67 050 032

Please insert digit  
for premounted insert

- thread 4-40 UNC ▶ 2
- thread M3 ▶ 3

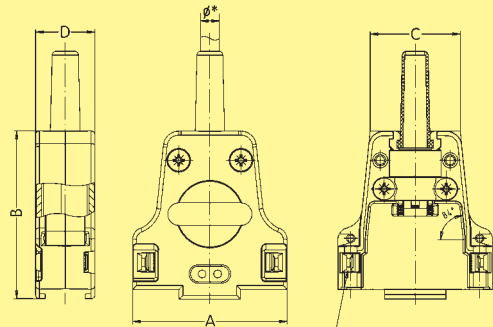

threaded insert

Poles	A	B	C	D	Ø F1		Ø F2
					Min.	Max.	
9	31.6	42.0	20.8	15.2	3.0	9.5	6.5
15	40.0	43.5	23.3	15.2	3.0	8.5	6.5
25	53.7	47.5	31.7	15.2	3.0	8.5	8.0
37	70.2	50.5	48.2	18.2	3.0	12.0	9.0
50	67.8	50.5	45.8	18.2	3.0	12.0	9.7

\* Cable diameter without rubber bushing = Ø F1  
Cable diameter with rubber bushing = Ø F2

### Locking hook

09 67 002 9031<sup>1)</sup>

### Latch lock bolt

Front mount

- thread 4-40 UNC
- thread M3

09 67 002 9041<sup>1)</sup>  
09 67 002 9042<sup>1)</sup>

Rear mount

- thread 4-40 UNC
- thread M3

09 67 002 9032<sup>1)</sup>  
09 67 002 9040<sup>1)</sup>

Cable to cable

- thread 4-40 UNC
- thread M3

09 67 002 9044<sup>1)</sup>  
09 67 002 9045<sup>1)</sup>

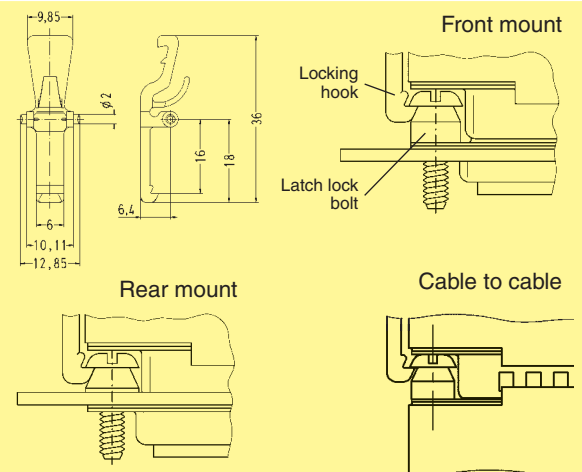

D-Sub

<sup>1)</sup> Order 2 for each hood





Full metal top and side entry hoods with different screw options

Identification      No. of contacts      Part No.      Drawing      Dimensions in mm

### 40° side entry hood

9	61 03 001 . 013
15	61 03 001 . 014
25	61 03 001 . 015

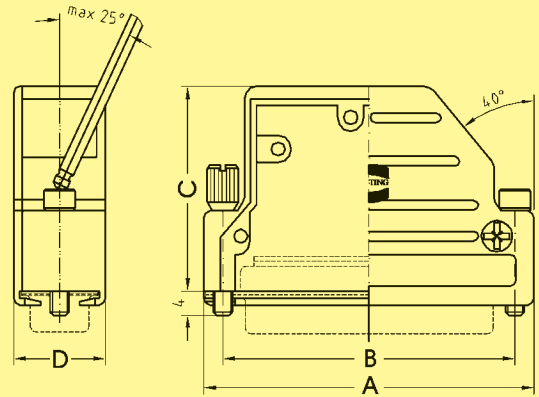

No. of contacts	A	B	C	D
9	31.0	25.0	35.0	15.0
15	39.3	33.3	35.0	15.0
25	53.0	47.0	35.0	15.0

### Top/side entry hood

9	61 03 001 . 010
15	61 03 001 . 016
25	61 03 001 . 017 <sup>1)</sup>
37	61 03 001 . 018 <sup>1)</sup>
50	61 03 001 . 019 <sup>1)</sup>

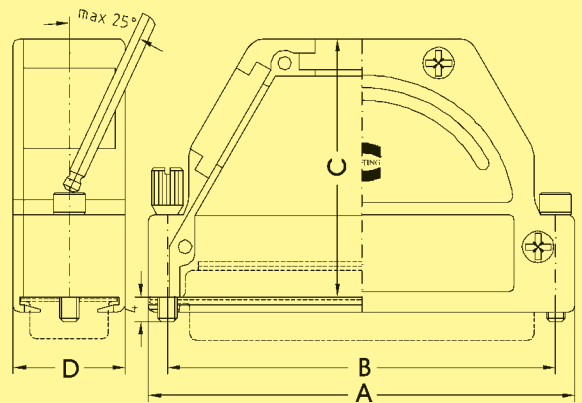

Please insert digit for screw option

- Knurled screw, thread 4-40 UNC ▶ 0
- Hexagonal screw, thread M3 with captive washer ▶ 1
- Hexagonal screw, thread 4-40 UNC with captive washer ▶ 2
- Knurled screw, thread M3 ▶ 3

No. of contacts	No. of cable entries	A	B	C	D
9	1 (top)	31.0	25.0	38.0	15.0
15	1 (top)	39.5	33.3	35.0	15.0
25	3	53.0	47.0	43.0	15.0
37	3	69.5	63.5	43.0	15.0
50	3	67.2	61.6	43.0	17.8

D-Sub

<sup>1)</sup> Part No. contains two blanking pieces

Connector hoods for spring or slide locking

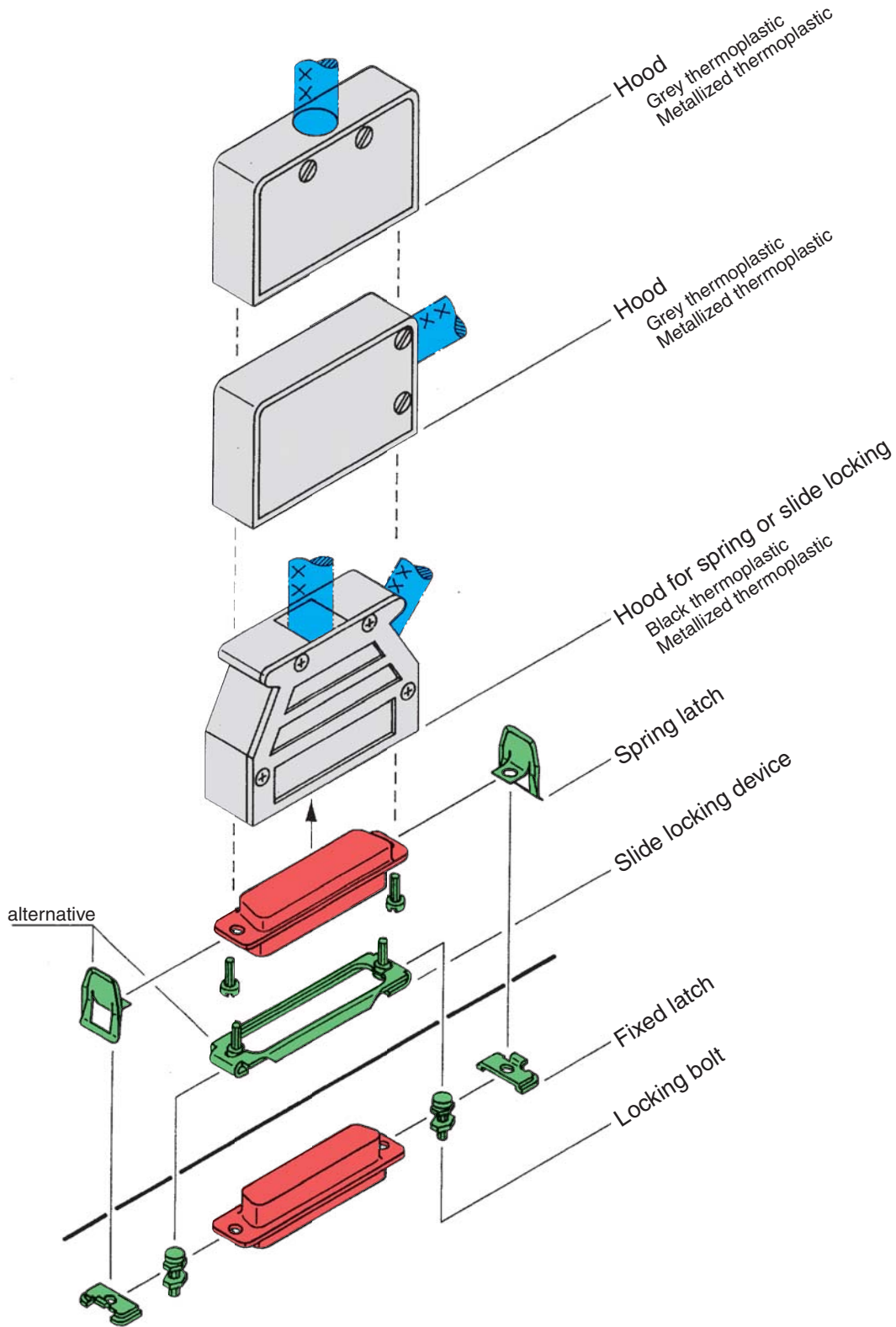

D-Sub



Thermoplastic top and side entry hoods for spring or slide locking

Identification      No. of contacts      Part No.      Drawing      Dimensions in mm

### Top entry hood

9  
15  
25  
37  
50

Thermoplastic grey  
09 67 009 0411  
09 67 015 0411  
09 67 025 0411  
09 67 037 0411  
09 67 050 0411

Thermoplastic metallized  
09 67 009 0413  
09 67 015 0413  
09 67 025 0413  
09 67 037 0413  
09 67 050 0413

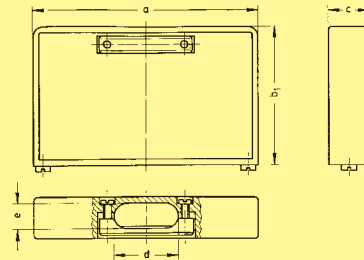

9-37 way for packaging density of 3 TE (15.24 mm)

	a	b <sub>1</sub>	b <sub>2</sub>	c	d	e	
						min.	max.
9	31.0	23	28	12.8	10	5.75	9.0
15	39.4	28	28	12.8	10	5.75	9.0
25	53.3	34	34	12.8	14	5.75	9.0
37	69.7	43	43	12.8	20	5.75	9.0
50	67.1	41	41	15.8	20	5.75	11.6

### Side entry hood

9  
15  
25  
37  
50

Thermoplastic grey  
09 67 009 0511  
09 67 015 0511  
09 67 025 0511  
09 67 037 0511  
09 67 050 0511

Thermoplastic metallized  
09 67 009 0513  
09 67 015 0513  
09 67 025 0513  
09 67 037 0513  
09 67 050 0513

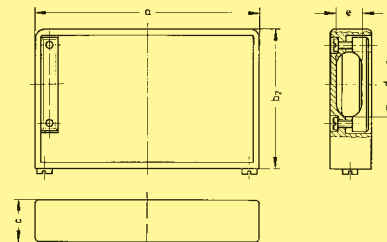

9-37 way for packaging density of 3 TE (15.24 mm)

### Top and side entry hood<sup>1)</sup>

9  
15  
25  
37  
50

Thermoplastic black  
09 67 009 0452  
09 67 015 0452  
09 67 025 0452  
09 67 037 0452  
09 67 050 0452

Thermoplastic metallized  
09 67 009 0453  
09 67 015 0453  
09 67 025 0453  
09 67 037 0453  
09 67 050 0453

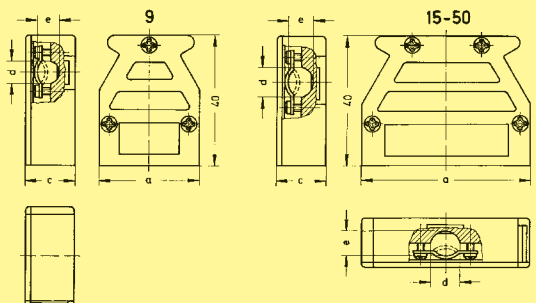

	a	c	d	e	
				min.	max.
9	31.0	15.4	7	1.7	7.5
15	39.4	15.4	7	1.7	8.0
25	53.2	15.4	9	1.5	8.0
37	69.5	15.4	9	1.5	8.0
50	67.0	17.9	9	1.5	8.0

<sup>1)</sup> 9 poles is only side entry  
Accessories see page 05.159

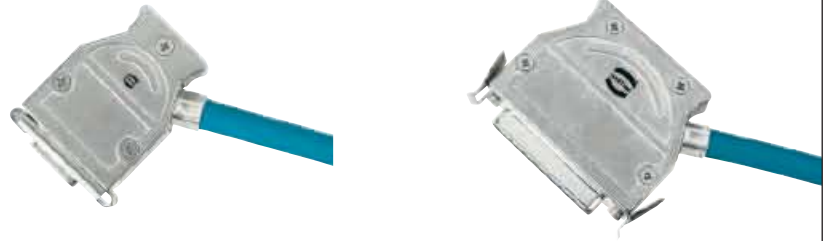

Full metal top and side entry hoods for spring or slide locking

Identification                      No. of contacts                      Part No.                      Drawing                      Dimensions in mm

Top/side entry hood with spring/slide locking

- 9                      61 03 001 0022<sup>1)</sup>
- 15                      61 03 001 0011<sup>2)</sup>
- 25                      61 03 001 0012<sup>2)</sup>
- 37                      61 03 001 0021<sup>2)</sup>
- 50                      61 03 001 0020<sup>2)</sup>

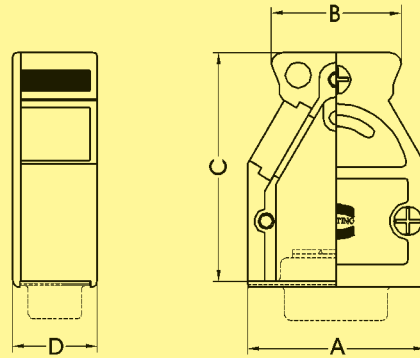

No. of contacts	No. of cable entries	A	B	C	D
9	2	31.0	22.6	40.0	14.8
15	3	39.0	30.6	40.0	14.8
25	3	53.0	42.6	40.0	14.8
37	3	69.5	59.2	40.0	14.8
50	3	67.0	55.0	40.0	17.6

D-Sub

<sup>1)</sup> Part No. contains one blanking piece  
<sup>2)</sup> Part No. contains two blanking pieces

## Accessories for spring or slide locking hoods

Identification	No. of contacts	Part No.	Drawing	Dimensions in mm																														
Spring latch	9-50	corrosion resistant steel 09 67 000 9907 <sup>1)</sup>																																
Fixed latch	9-37 50	corrosion resistant steel 09 67 001 9971 <sup>1)</sup> 09 67 001 9972 <sup>1)</sup>																																
Slide locking device	9 15 25 37 50	corrosion resistant steel 09 67 000 9914 09 67 000 9915 09 67 000 9916 09 67 000 9917 09 67 000 9918	 <table border="1"> <thead> <tr> <th></th> <th>a</th> <th>b</th> <th>c</th> <th>d</th> </tr> </thead> <tbody> <tr> <td>9</td> <td>35.6</td> <td>25.0</td> <td>12.0</td> <td>10.0</td> </tr> <tr> <td>15</td> <td>44.0</td> <td>33.3</td> <td>12.0</td> <td>10.0</td> </tr> <tr> <td>25</td> <td>57.8</td> <td>47.0</td> <td>12.0</td> <td>10.0</td> </tr> <tr> <td>37</td> <td>74.3</td> <td>63.5</td> <td>12.0</td> <td>10.0</td> </tr> <tr> <td>50</td> <td>72.0</td> <td>61.1</td> <td>14.8</td> <td>13.5</td> </tr> </tbody> </table>		a	b	c	d	9	35.6	25.0	12.0	10.0	15	44.0	33.3	12.0	10.0	25	57.8	47.0	12.0	10.0	37	74.3	63.5	12.0	10.0	50	72.0	61.1	14.8	13.5	
	a	b	c	d																														
9	35.6	25.0	12.0	10.0																														
15	44.0	33.3	12.0	10.0																														
25	57.8	47.0	12.0	10.0																														
37	74.3	63.5	12.0	10.0																														
50	72.0	61.1	14.8	13.5																														
Locking bolt	9-50	tinned 09 67 001 9973 <sup>1)</sup>																																

D-Sub

<sup>1)</sup> Order 2 for each connector



## Accessories for full metal hoods

Identification	Part No.		Drawing	Dimensions in mm																																																																																																			
Crimp flange	Hoods for 9-37 pole D-Sub	Hoods for 50 pole D-Sub	<table border="1"> <thead> <tr> <th>D1</th> <th>D2</th> </tr> </thead> <tbody> <tr><td>3.0</td><td>4.0</td></tr> <tr><td>3.5</td><td>4.5</td></tr> <tr><td>4.0</td><td>5.0</td></tr> <tr><td>4.5</td><td>5.5</td></tr> <tr><td>5.0</td><td>6.0</td></tr> <tr><td>5.5</td><td>6.5</td></tr> <tr><td>6.0</td><td>7.0</td></tr> <tr><td>6.5</td><td>7.5</td></tr> <tr><td>7.0</td><td>8.0</td></tr> <tr><td>7.5</td><td>8.5</td></tr> <tr><td>8.0</td><td>9.0</td></tr> <tr><td>8.5</td><td>9.5</td></tr> <tr><td>9.0</td><td>10.0</td></tr> </tbody> </table>	D1	D2	3.0	4.0	3.5	4.5	4.0	5.0	4.5	5.5	5.0	6.0	5.5	6.5	6.0	7.0	6.5	7.5	7.0	8.0	7.5	8.5	8.0	9.0	8.5	9.5	9.0	10.0	<table border="1"> <thead> <tr> <th>D1</th> <th>D2</th> </tr> </thead> <tbody> <tr><td>3.0</td><td>4.0</td></tr> <tr><td>3.5</td><td>4.5</td></tr> <tr><td>4.0</td><td>5.0</td></tr> <tr><td>4.5</td><td>5.5</td></tr> <tr><td>5.0</td><td>6.0</td></tr> <tr><td>5.5</td><td>6.5</td></tr> <tr><td>6.0</td><td>7.0</td></tr> <tr><td>6.5</td><td>7.5</td></tr> <tr><td>7.0</td><td>8.0</td></tr> <tr><td>7.5</td><td>8.5</td></tr> <tr><td>8.0</td><td>9.0</td></tr> <tr><td>8.5</td><td>9.5</td></tr> <tr><td>9.0</td><td>10.0</td></tr> </tbody> </table>	D1	D2	3.0	4.0	3.5	4.5	4.0	5.0	4.5	5.5	5.0	6.0	5.5	6.5	6.0	7.0	6.5	7.5	7.0	8.0	7.5	8.5	8.0	9.0	8.5	9.5	9.0	10.0																																											
	D1	D2																																																																																																					
	3.0	4.0																																																																																																					
	3.5	4.5																																																																																																					
	4.0	5.0																																																																																																					
	4.5	5.5																																																																																																					
	5.0	6.0																																																																																																					
	5.5	6.5																																																																																																					
	6.0	7.0																																																																																																					
	6.5	7.5																																																																																																					
	7.0	8.0																																																																																																					
	7.5	8.5																																																																																																					
	8.0	9.0																																																																																																					
	8.5	9.5																																																																																																					
	9.0	10.0																																																																																																					
D1	D2																																																																																																						
3.0	4.0																																																																																																						
3.5	4.5																																																																																																						
4.0	5.0																																																																																																						
4.5	5.5																																																																																																						
5.0	6.0																																																																																																						
5.5	6.5																																																																																																						
6.0	7.0																																																																																																						
6.5	7.5																																																																																																						
7.0	8.0																																																																																																						
7.5	8.5																																																																																																						
8.0	9.0																																																																																																						
8.5	9.5																																																																																																						
9.0	10.0																																																																																																						
Crimp ferrule	<table border="1"> <tbody> <tr><td>61 03 000 0045</td></tr> <tr><td>61 03 000 0046</td></tr> <tr><td>61 03 000 0047</td></tr> <tr><td>61 03 000 0048</td></tr> <tr><td>61 03 000 0049</td></tr> <tr><td>61 03 000 0050</td></tr> <tr><td>61 03 000 0051</td></tr> <tr><td>61 03 000 0052</td></tr> <tr><td>61 03 000 0053</td></tr> <tr><td>61 03 000 0054</td></tr> <tr><td>61 03 000 0055</td></tr> <tr><td>61 03 000 0056</td></tr> <tr><td>61 03 000 0057</td></tr> <tr><td>61 03 000 0058</td></tr> <tr><td>61 03 000 0142</td></tr> <tr><td>61 03 000 0059</td></tr> <tr><td>61 03 000 0127</td></tr> <tr><td>61 03 000 0060</td></tr> <tr><td>61 03 000 0061</td></tr> </tbody> </table>		61 03 000 0045	61 03 000 0046	61 03 000 0047	61 03 000 0048	61 03 000 0049	61 03 000 0050	61 03 000 0051	61 03 000 0052	61 03 000 0053	61 03 000 0054	61 03 000 0055	61 03 000 0056	61 03 000 0057	61 03 000 0058	61 03 000 0142	61 03 000 0059	61 03 000 0127	61 03 000 0060	61 03 000 0061	<table border="1"> <thead> <tr> <th>D3</th> <th>D4</th> </tr> </thead> <tbody> <tr><td>5.0</td><td>6.0</td></tr> <tr><td>5.5</td><td>6.5</td></tr> <tr><td>6.0</td><td>7.0</td></tr> <tr><td>6.5</td><td>7.5</td></tr> <tr><td>7.0</td><td>8.0</td></tr> <tr><td>7.5</td><td>8.5</td></tr> <tr><td>8.0</td><td>9.0</td></tr> <tr><td>8.5</td><td>9.5</td></tr> <tr><td>9.0</td><td>10.0</td></tr> <tr><td>9.5</td><td>10.5</td></tr> <tr><td>10.0</td><td>11.0</td></tr> <tr><td>10.5</td><td>11.5</td></tr> <tr><td>11.0</td><td>12.0</td></tr> <tr><td>11.5</td><td>12.5</td></tr> <tr><td>12.0</td><td>13.0</td></tr> <tr><td>12.5</td><td>13.5</td></tr> <tr><td>13.0</td><td>14.0</td></tr> <tr><td>13.7</td><td>15.0</td></tr> <tr><td>14.0</td><td>15.0</td></tr> </tbody> </table>	D3	D4	5.0	6.0	5.5	6.5	6.0	7.0	6.5	7.5	7.0	8.0	7.5	8.5	8.0	9.0	8.5	9.5	9.0	10.0	9.5	10.5	10.0	11.0	10.5	11.5	11.0	12.0	11.5	12.5	12.0	13.0	12.5	13.5	13.0	14.0	13.7	15.0	14.0	15.0	<table border="1"> <thead> <tr> <th>D3</th> <th>D4</th> </tr> </thead> <tbody> <tr><td>5.0</td><td>6.0</td></tr> <tr><td>5.5</td><td>6.5</td></tr> <tr><td>6.0</td><td>7.0</td></tr> <tr><td>6.5</td><td>7.5</td></tr> <tr><td>7.0</td><td>8.0</td></tr> <tr><td>7.5</td><td>8.5</td></tr> <tr><td>8.0</td><td>9.0</td></tr> <tr><td>8.5</td><td>9.5</td></tr> <tr><td>9.0</td><td>10.0</td></tr> <tr><td>9.5</td><td>10.5</td></tr> <tr><td>10.0</td><td>11.0</td></tr> <tr><td>10.5</td><td>11.5</td></tr> <tr><td>11.0</td><td>12.0</td></tr> <tr><td>11.5</td><td>12.5</td></tr> <tr><td>12.0</td><td>13.0</td></tr> <tr><td>12.5</td><td>13.5</td></tr> <tr><td>13.0</td><td>14.0</td></tr> <tr><td>13.7</td><td>15.0</td></tr> <tr><td>14.0</td><td>15.0</td></tr> </tbody> </table>	D3	D4	5.0	6.0	5.5	6.5	6.0	7.0	6.5	7.5	7.0	8.0	7.5	8.5	8.0	9.0	8.5	9.5	9.0	10.0	9.5	10.5	10.0	11.0	10.5	11.5	11.0	12.0	11.5	12.5	12.0	13.0	12.5	13.5	13.0	14.0	13.7	15.0	14.0	15.0
	61 03 000 0045																																																																																																						
	61 03 000 0046																																																																																																						
	61 03 000 0047																																																																																																						
	61 03 000 0048																																																																																																						
	61 03 000 0049																																																																																																						
	61 03 000 0050																																																																																																						
	61 03 000 0051																																																																																																						
	61 03 000 0052																																																																																																						
	61 03 000 0053																																																																																																						
	61 03 000 0054																																																																																																						
	61 03 000 0055																																																																																																						
	61 03 000 0056																																																																																																						
	61 03 000 0057																																																																																																						
	61 03 000 0058																																																																																																						
61 03 000 0142																																																																																																							
61 03 000 0059																																																																																																							
61 03 000 0127																																																																																																							
61 03 000 0060																																																																																																							
61 03 000 0061																																																																																																							
D3	D4																																																																																																						
5.0	6.0																																																																																																						
5.5	6.5																																																																																																						
6.0	7.0																																																																																																						
6.5	7.5																																																																																																						
7.0	8.0																																																																																																						
7.5	8.5																																																																																																						
8.0	9.0																																																																																																						
8.5	9.5																																																																																																						
9.0	10.0																																																																																																						
9.5	10.5																																																																																																						
10.0	11.0																																																																																																						
10.5	11.5																																																																																																						
11.0	12.0																																																																																																						
11.5	12.5																																																																																																						
12.0	13.0																																																																																																						
12.5	13.5																																																																																																						
13.0	14.0																																																																																																						
13.7	15.0																																																																																																						
14.0	15.0																																																																																																						
D3	D4																																																																																																						
5.0	6.0																																																																																																						
5.5	6.5																																																																																																						
6.0	7.0																																																																																																						
6.5	7.5																																																																																																						
7.0	8.0																																																																																																						
7.5	8.5																																																																																																						
8.0	9.0																																																																																																						
8.5	9.5																																																																																																						
9.0	10.0																																																																																																						
9.5	10.5																																																																																																						
10.0	11.0																																																																																																						
10.5	11.5																																																																																																						
11.0	12.0																																																																																																						
11.5	12.5																																																																																																						
12.0	13.0																																																																																																						
12.5	13.5																																																																																																						
13.0	14.0																																																																																																						
13.7	15.0																																																																																																						
14.0	15.0																																																																																																						
Cable clamp	cable-Ø appr. 5- 7 mm	61 03 000 0141																																																																																																					
	cable-Ø appr. 7-10 mm	61 03 000 0044																																																																																																					
	cable-Ø appr. 10-12 mm	61 03 000 0143																																																																																																					
	cable-Ø appr. 11-14 mm	61 03 000 0145																																																																																																					
Blanking piece for hoods	61 03 000 0042	61 03 000 0041																																																																																																					
Hexagonal screw	thread 4-40 UNC x 17.5-8.8 with captive washer	09 67 002 9020																																																																																																					
	thread M3 x 17.5-8.8 with captive washer	09 67 002 9019																																																																																																					
Knurled screw	thread 4-40 UNC	09 67 002 9018																																																																																																					
	thread M3	09 67 002 9017																																																																																																					

### Crimp flange termination instruction

1. Strip the cable sheath to the correct length (approx. 35 to 40 mm, depending on interface type).
2. Place the crimp ferrule over the cable sheath. Bend the outer screen backwards over the cable sheath. Cut screen approx. 2 mm from the end of the cable sheath.
3. Place the crimp flange over the wires covered by the remaining foil shield. Push and twist the crimp flange under the outer screen and cable sheath until the end of the cable sheath touches the crimp flange. HARTING has developed a special tool for optimised installation of the shielding over the crimp flange, part number 61 03 600 0017.
4. Move the crimp ferrule back onto the crimp flange and crimp the two parts together with the special service crimp tool part number 61 03 600 0020. For an optimised crimp process the tool should be positioned as close as possible to the crimp flange shoulder.
5. Cut off the internal screen foil and push the crimp flange inside the metal hood.

**HARTING offers to test and define the best crimp flange and ferrule combination for customer specific cables.**

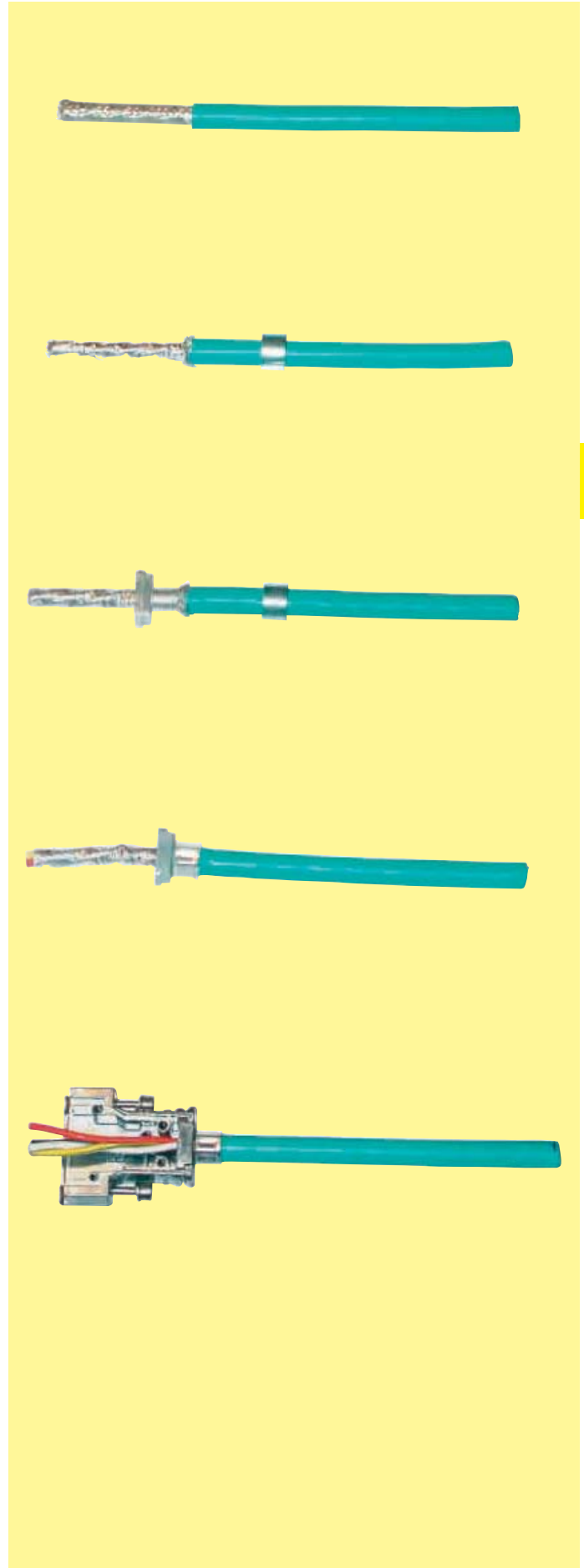

## Accessories

Identification	No. of contacts	Part No.	Drawing	Dimensions in mm
Female screw locks without nut	9-50	09 67 000 9972 <sup>1)</sup>		
	9-50	09 67 000 9974 <sup>1)</sup>		
Thread M3/UNC	9-50	09 67 001 9976 <sup>1)</sup>		
	9-50	09 67 001 9974 <sup>1)</sup>		
Thread UNC/UNC	9-50	09 67 001 9941 <sup>1)</sup>		
	9-50	09 67 001 9954 <sup>1)</sup>		
for press-in connectors with grounding-pins or straight solder with grounding-clips.	9-50	09 66 000 9972 <sup>1)</sup>		
	9-50	09 66 000 9974 <sup>1)2)</sup>		
with captive washer	9-50	09 67 001 9957 <sup>1)</sup>		
with spring washer	9-50	09 67 001 9939 <sup>1)</sup>		

D-Sub

<sup>1)</sup> Order 2 for each connector  
<sup>2)</sup> M3 inner thread available on request

## Accessories

Identification	No. of contacts	Part No.	Drawing	Dimensions in mm	
Female screw locks with nut	9-50	09 67 000 9922 <sup>1)</sup> 09 67 000 9924 <sup>1)</sup>			
					Thread UNC/UNC
					Thread UNC/M3
Thread UNC/UNC	9-50	09 67 000 9973 <sup>1)</sup>			
Male screw locks for use without hood	9-37 50	09 67 001 9969 <sup>1)</sup> 09 67 001 9970 <sup>1)</sup>			
Hex extender	9-50	09 67 001 9985			
U-Clip with thread 4-40 UNC	9-50	09 67 001 9928 <sup>1)</sup>			
with thread 4-40 UNC and screw-lock	9-50	09 67 002 9030 <sup>1)</sup>			

D-Sub

<sup>1)</sup> Order 2 for each connector

## Accessories

Identification	No. of contacts	Part No.	Drawing	Dimensions in mm															
<b>Dust cap</b> black thermoplastic  for male connector	9	09 67 009 0611		<table border="1"> <thead> <tr> <th></th> <th>A</th> <th>B</th> </tr> </thead> <tbody> <tr> <td>9</td> <td>17.0</td> <td>22.40</td> </tr> <tr> <td>15</td> <td>25.3</td> <td>30.80</td> </tr> <tr> <td>25</td> <td>38.9</td> <td>44.40</td> </tr> <tr> <td>37</td> <td>55.4</td> <td>60.75</td> </tr> </tbody> </table>		A	B	9	17.0	22.40	15	25.3	30.80	25	38.9	44.40	37	55.4	60.75
		A		B															
	9	17.0		22.40															
	15	25.3		30.80															
25	38.9	44.40																	
37	55.4	60.75																	
15	09 67 015 0611																		
25	09 67 025 0611																		
37	09 67 037 0611																		
for female connector	9	09 67 009 0711		<table border="1"> <thead> <tr> <th></th> <th>A</th> <th>B</th> </tr> </thead> <tbody> <tr> <td>9</td> <td>16.0</td> <td>22.5</td> </tr> <tr> <td>15</td> <td>24.4</td> <td>31.0</td> </tr> <tr> <td>25</td> <td>37.8</td> <td>44.3</td> </tr> <tr> <td>37</td> <td>54.3</td> <td>60.8</td> </tr> </tbody> </table>		A	B	9	16.0	22.5	15	24.4	31.0	25	37.8	44.3	37	54.3	60.8
		A		B															
	9	16.0		22.5															
	15	24.4		31.0															
25	37.8	44.3																	
37	54.3	60.8																	
15	09 67 015 0711																		
25	09 67 025 0711																		
37	09 67 037 0711																		
<b>antistatic</b> black thermoplastic  for male connector	9	09 67 009 0612		<table border="1"> <thead> <tr> <th></th> <th>A</th> <th>B</th> </tr> </thead> <tbody> <tr> <td>9</td> <td>17.7</td> <td>21.8</td> </tr> <tr> <td>15</td> <td>26.0</td> <td>30.0</td> </tr> <tr> <td>25</td> <td>40.0</td> <td>44.2</td> </tr> <tr> <td>37</td> <td>56.4</td> <td>59.8</td> </tr> </tbody> </table>		A	B	9	17.7	21.8	15	26.0	30.0	25	40.0	44.2	37	56.4	59.8
		A		B															
	9	17.7		21.8															
	15	26.0		30.0															
25	40.0	44.2																	
37	56.4	59.8																	
15	09 67 015 0612																		
25	09 67 025 0612																		
37	09 67 037 0612																		
for female connector	9	09 67 009 0712		<table border="1"> <thead> <tr> <th></th> <th>A</th> <th>B</th> </tr> </thead> <tbody> <tr> <td>9</td> <td>15.9</td> <td>20.0</td> </tr> <tr> <td>15</td> <td>24.4</td> <td>28.5</td> </tr> <tr> <td>25</td> <td>38.3</td> <td>42.3</td> </tr> <tr> <td>37</td> <td>54.7</td> <td>58.8</td> </tr> </tbody> </table>		A	B	9	15.9	20.0	15	24.4	28.5	25	38.3	42.3	37	54.7	58.8
		A		B															
	9	15.9		20.0															
	15	24.4		28.5															
25	38.3	42.3																	
37	54.7	58.8																	
15	09 67 015 0712																		
25	09 67 025 0712																		
37	09 67 037 0712																		
<b>UL 94 V0</b> grey thermoplastic  for male connector	9	09 67 009 0613		<table border="1"> <thead> <tr> <th></th> <th>A</th> <th>B</th> </tr> </thead> <tbody> <tr> <td>9</td> <td>17.7</td> <td>21.8</td> </tr> <tr> <td>15</td> <td>26.0</td> <td>30.0</td> </tr> <tr> <td>25</td> <td>40.0</td> <td>44.2</td> </tr> <tr> <td>37</td> <td>56.4</td> <td>59.8</td> </tr> </tbody> </table>		A	B	9	17.7	21.8	15	26.0	30.0	25	40.0	44.2	37	56.4	59.8
		A		B															
	9	17.7		21.8															
	15	26.0		30.0															
25	40.0	44.2																	
37	56.4	59.8																	
15	09 67 015 0613																		
25	09 67 025 0613																		
37	09 67 037 0613																		
for female connector	9	09 67 009 0713		<table border="1"> <thead> <tr> <th></th> <th>A</th> <th>B</th> </tr> </thead> <tbody> <tr> <td>9</td> <td>15.9</td> <td>20.0</td> </tr> <tr> <td>15</td> <td>24.4</td> <td>28.5</td> </tr> <tr> <td>25</td> <td>38.3</td> <td>42.3</td> </tr> <tr> <td>37</td> <td>54.7</td> <td>58.8</td> </tr> </tbody> </table>		A	B	9	15.9	20.0	15	24.4	28.5	25	38.3	42.3	37	54.7	58.8
		A		B															
	9	15.9		20.0															
	15	24.4		28.5															
25	38.3	42.3																	
37	54.7	58.8																	
15	09 67 015 0713																		
25	09 67 025 0713																		
37	09 67 037 0713																		

D-Sub

Accessories

Identification	No. of contacts	Part No.	Drawing	Dimensions in mm																														
Dust cap metallized metallized thermoplastic	for male connector	9		<table border="1"> <thead> <tr> <th></th> <th>A</th> <th>B</th> <th>C</th> <th>D</th> </tr> </thead> <tbody> <tr> <td>9</td> <td>17.7</td> <td>21.8</td> <td>13.2</td> <td>9.1</td> </tr> <tr> <td>15</td> <td>26.0</td> <td>30.0</td> <td>13.2</td> <td>9.1</td> </tr> <tr> <td>25</td> <td>40.0</td> <td>44.2</td> <td>13.2</td> <td>9.1</td> </tr> <tr> <td>37</td> <td>56.4</td> <td>59.8</td> <td>13.2</td> <td>9.1</td> </tr> <tr> <td>50</td> <td>53.9</td> <td>57.8</td> <td>15.9</td> <td>11.7</td> </tr> </tbody> </table>		A	B	C	D	9	17.7	21.8	13.2	9.1	15	26.0	30.0	13.2	9.1	25	40.0	44.2	13.2	9.1	37	56.4	59.8	13.2	9.1	50	53.9	57.8	15.9	11.7
					A	B	C	D																										
		9			17.7	21.8	13.2	9.1																										
		15			26.0	30.0	13.2	9.1																										
		25			40.0	44.2	13.2	9.1																										
37	56.4	59.8	13.2	9.1																														
50	53.9	57.8	15.9	11.7																														
15	09 67 015 0614																																	
25	09 67 025 0614																																	
37	09 67 037 0614																																	
50	09 67 050 0614																																	
for female connector	9 15 25 37 50	09 67 009 0714		<table border="1"> <thead> <tr> <th></th> <th>A</th> <th>B</th> <th>C</th> <th>D</th> </tr> </thead> <tbody> <tr> <td>9</td> <td>15.9</td> <td>20.0</td> <td>11.8</td> <td>7.8</td> </tr> <tr> <td>15</td> <td>24.4</td> <td>28.5</td> <td>11.8</td> <td>7.8</td> </tr> <tr> <td>25</td> <td>38.3</td> <td>42.3</td> <td>11.8</td> <td>7.8</td> </tr> <tr> <td>37</td> <td>54.7</td> <td>58.8</td> <td>11.8</td> <td>7.8</td> </tr> <tr> <td>50</td> <td>52.6</td> <td>56.2</td> <td>14.5</td> <td>10.5</td> </tr> </tbody> </table>		A	B	C	D	9	15.9	20.0	11.8	7.8	15	24.4	28.5	11.8	7.8	25	38.3	42.3	11.8	7.8	37	54.7	58.8	11.8	7.8	50	52.6	56.2	14.5	10.5
					A	B	C	D																										
		9			15.9	20.0	11.8	7.8																										
		15			24.4	28.5	11.8	7.8																										
		25			38.3	42.3	11.8	7.8																										
37	54.7	58.8	11.8	7.8																														
50	52.6	56.2	14.5	10.5																														
09 67 015 0714																																		
09 67 025 0714																																		
09 67 037 0714																																		
09 67 050 0714																																		

D-Sub

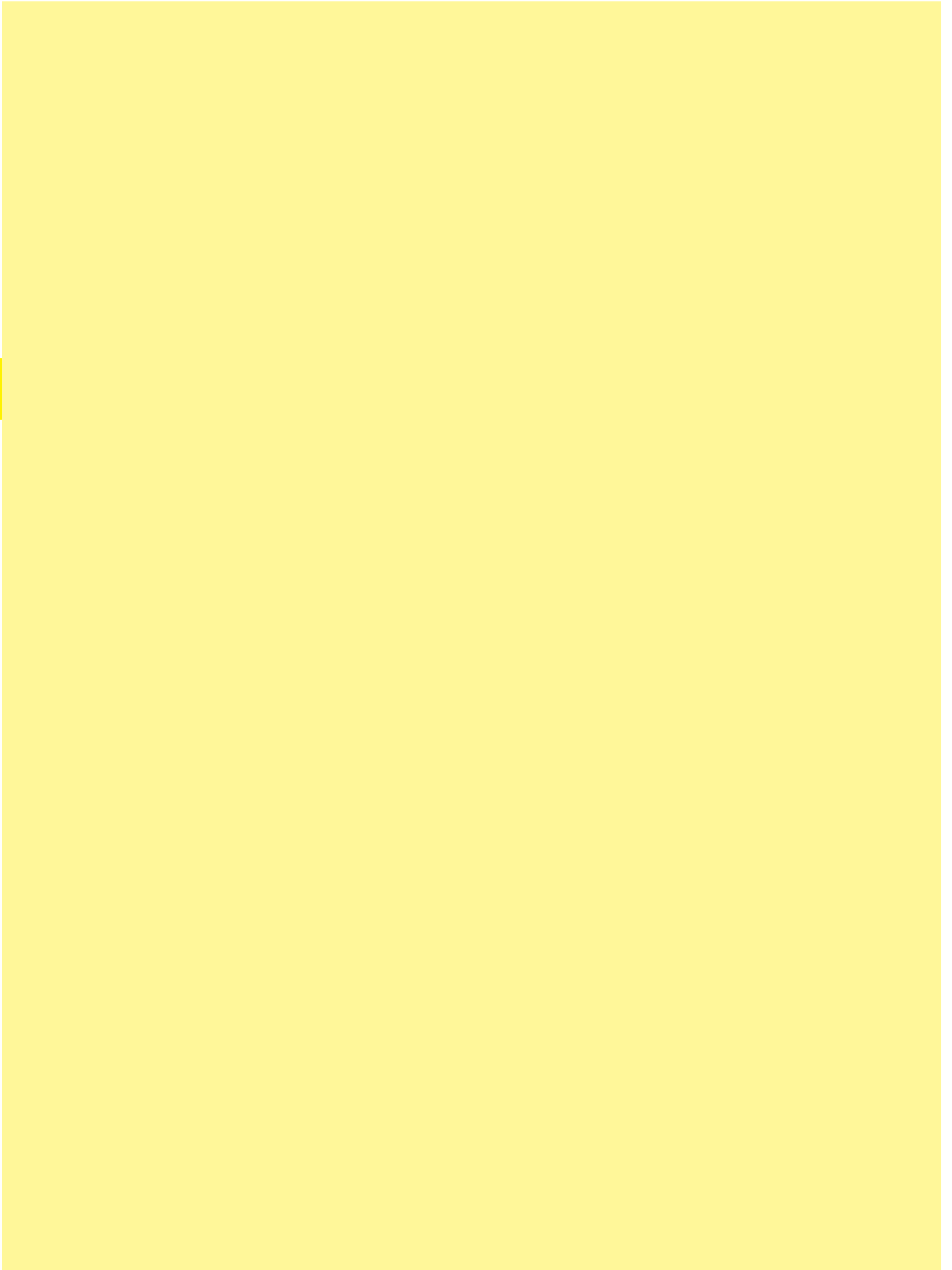

D-Sub

Number of contacts 9, 15, 25, 37, 50  
UL recognized

Working current  
see current carrying capacity chart  
Stamped contacts 6.5 A max.

Test voltage  $U_{r.m.s.}$  1 kV

Clearance and creepage  $\geq 1.0$  mm

Contact resistance  $\leq 10$  m $\Omega$   
Insulation resistance  $\geq 10^{10}$   $\Omega$

Temperature range -55 °C ... + 125 °C  
The higher temperature limit includes the local ambient and heating effect of the contacts under load

Terminations Recommended PCB through holes

		Signal pin	Grounding pin
--	--	------------	---------------

Tin-lead plated PCB	Hole	1.15 <sup>-0.03</sup>	3.15 <sup>±0.025</sup>
	Cu	25-75 $\mu$ m	25-75 $\mu$ m
	Sn	5-15 $\mu$ m	4-10 $\mu$ m
	Plated hole	0.94-1.09 mm	3.0-3.15 mm

Chemical tin-plated PCB	Hole	1.05 <sup>-0.03</sup>	3.15 <sup>±0.025</sup>
	Cu	25-50 $\mu$ m	25-50 $\mu$ m
	Sn	0.8-1.0 $\mu$ m	0.8-1.0 $\mu$ m
	Plated hole	1.00-1.10 mm	3.0-3.15 mm

Au / Ni plated PCB	Hole	1.15 <sup>-0.03</sup>	3.15 <sup>±0.025</sup>
	Cu	25-50 $\mu$ m	25-50 $\mu$ m
	Ni	3-7 $\mu$ m	4-7 $\mu$ m
	Au	0.05-0.12 $\mu$ m	0.05-0.12 $\mu$ m
	Plated hole	1.00-1.10 mm	3.0-3.15 mm

Silver plated PCB	Hole	1.15 <sup>-0.03</sup>	3.15 <sup>±0.025</sup>
	Cu	25-50 $\mu$ m	25-50 $\mu$ m
	Ag	0.1-0.3 $\mu$ m	0.1-0.3 $\mu$ m
	Plated hole	1.00-1.10 mm	3.0-3.15 mm

OSP copper plated PCB	Hole	1.15 <sup>-0.03</sup>	3.15 <sup>±0.025</sup>
	Cu	25-50 $\mu$ m	25-50 $\mu$ m
	Plated hole	1.00-1.10 mm	3.0-3.15 mm

PCB board thickness:  $\geq 1.6$  mm

Materials  
Mouldings and hoods Liquid Crystal Polymer (LCP)  
UL 94-V0

Contacts Copper alloy

Contact surface  
Contact zone selectively gold-plated  
acc. to performance level<sup>1)</sup>

Metal shell Plated steel

Insertion and withdrawal force

Connector on P.C.B.  
Press-in without grounding pins  
– insertion max. per contact: 120 N  
– withdrawal min. per contact: 20 N  
Press-in with grounding pins  
– insertion max. per grounding pin: 250 N  
– withdrawal min. per grounding pin: 30 N

Mating force  
9 way  $\leq 30$  N  
15 way  $\leq 50$  N  
25 way  $\leq 83$  N  
37 way  $\leq 123$  N  
50 way  $\leq 167$  N

Current carrying capacity

The current carrying capacity is limited by maximum temperature of materials for inserts and contacts including terminals.

The current capacity-curve is valid for continuous, not interrupted current-loaded contacts of connectors when simultaneous power on all contacts is given, without exceeding the maximum temperature.

Control and test procedures according to DIN IEC 60512.

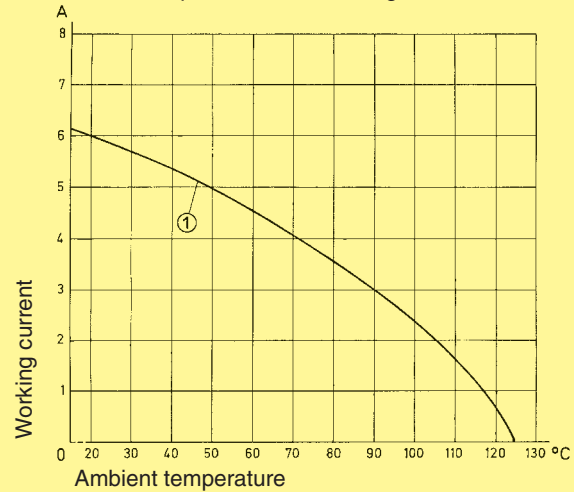

Example: 25 way connector

① Stamped contacts

Contact arrangement View from termination side

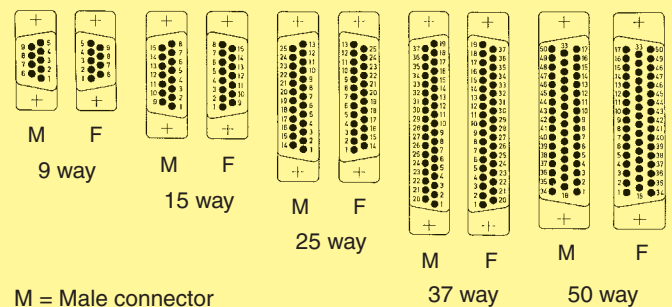

M = Male connector  
F = Female connector

Mating conditions as per DIN 41 652

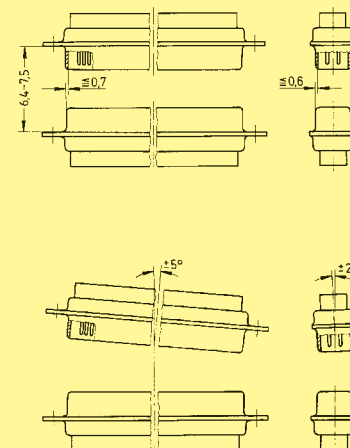

<sup>1)</sup> Performance level 3, 50 mating cycles, no gas test  
Performance level 2 as per CECC 75301-802, 250 mating cycles, 4 days 4 mixed gas test – IEC 60512  
Performance level 1 as per CECC 75301-802, 500 mating cycles, 10 days 4 mixed gas test – IEC 60512



Number of contacts

# 9–50

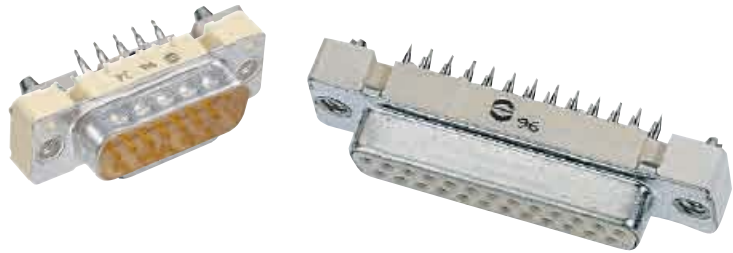

Press-in, straight with grounding press-in board locks

Identification	No. of contacts	Part No.	
<b>Performance levels</b> Explanations see page 05.167 Other performance levels on request		Performance level <b>3</b>	Performance level <b>2</b>
<b>Male connector</b> Flange height x = 5.7 mm			
metal shell with dimples	9	09 66 164 771 .	09 66 164 671 .
	15	09 66 264 771 .	09 66 264 671 .
	25	09 66 364 771 .	09 66 364 671 .
Please insert digit for flange thread or fitted female screw locks			
M3 ▶ 5 4-40 UNC ▶ 6 fitted screw locks 4-40 UNC ▶ 7 <sup>1)</sup>			
<b>Female connector</b> Flange height x = 5.7 mm			
metal shell	9	09 66 154 751 .	09 66 154 651 .
	15	09 66 254 751 .	09 66 254 651 .
	25	09 66 354 751 .	09 66 354 651 .
	37	09 66 454 751 .	09 66 454 651 .
Please insert digit for flange thread or fitted female screw locks			
M3 ▶ 5 4-40 UNC ▶ 6 fitted screw locks 4-40 UNC ▶ 7 <sup>1)</sup>			
<b>Female connector</b> Flange height x = 6 mm			
metal shell	9	09 66 154 751 .	09 66 154 651 .
	15	09 66 254 751 .	09 66 254 651 .
	25	09 66 354 751 .	09 66 354 651 .
	37	09 66 454 751 .	09 66 454 651 .
	50	09 66 554 751 .	09 66 554 651 .
Please insert digit for flange thread or fitted female screw locks			
M3 ▶ 1 4-40 UNC ▶ 2 fitted screw locks 4-40 UNC ▶ 3 <sup>1)</sup>			

D-Sub

<sup>1)</sup> Fitted screw locks 4-40 UNC not normally kept in stock for performance level 3  
 Connector dimensions see page 05.169. Mating conditions see page 05.167.

Number of contacts

# 9-50

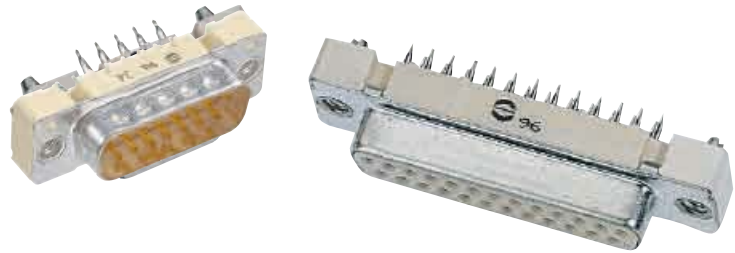

Press-in, straight with grounding press-in board locks

Identification

Drawing

Dimensions in mm

**Male connector**  
9 – 25 contacts

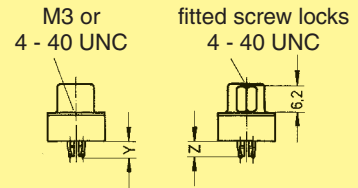
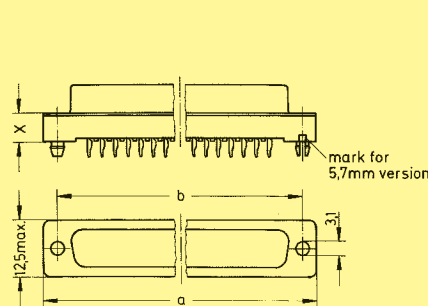

X	Y	Z
6.0 ± 0.2	4.20 ± 0.2	3.5 max.
5.7 ± 0.2	4.35 ± 0.2	3.9 max.

**Female connector**  
9 – 37 contacts

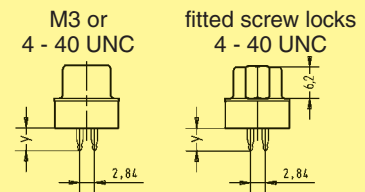
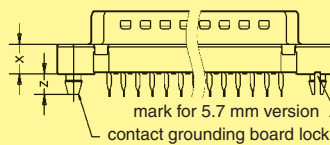

Mating face acc. to: DIN 41 652 · CECC 75 301-802 · IEC 60 807

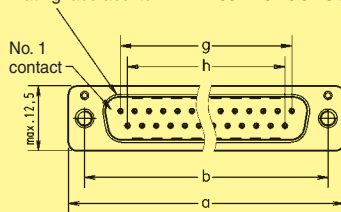

	a	b	g	h
9	31.00	24.90	4 x [2.74] = 10.96	3 x [2.74] = 8.22
15	39.30	33.20	7 x [2.74] = 19.18	6 x [2.74] = 16.44
25	53.10	47.00	12 x [2.76] = 33.12	11 x [2.76] = 30.36
37	69.65	63.55	18 x [2.76] = 49.68	17 x [2.76] = 46.92
50	67.00	61.10	16 x [2.76] = 44.16	15 x [2.76] = 41.40

**Female connector**  
50 contacts

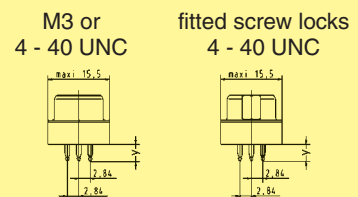
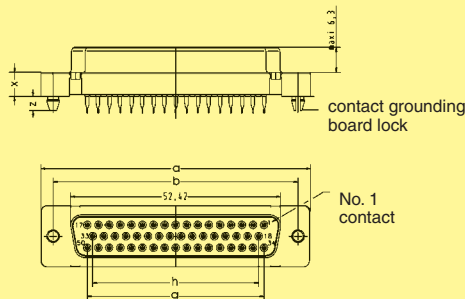

Board drillings

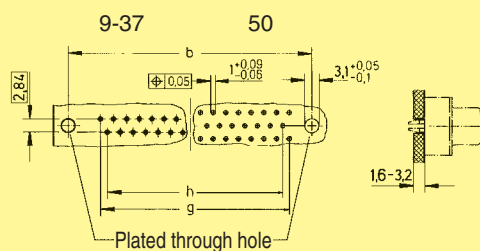

D-Sub

Number of contacts

# 9-50



Press-in, straight without grounding press-in board locks

Identification	No. of contacts	Part No.	
		Performance level 3	Performance level 2
<b>Performance levels</b> Explanations see page 05.167 Other performance levels on request			
<b>Male connector</b> Flange height x = 5.7 mm			
metal shell with dimples	9	09 66 124 770 .	09 66 124 670 .
	15	09 66 224 770 .	09 66 224 670 .
	25	09 66 324 770 .	09 66 324 670 .
Please insert digit for flange thread or fitted female screw locks			
ø 3.1 mm hole ▶ 4 <sup>1)</sup>			
M3 ▶ 5			
4-40 UNC ▶ 6			
fitted screw locks 4-40 UNC ▶ 7 <sup>2)</sup>			
<b>Female connector</b> Flange height x = 5.7 mm			
metal shell	9	09 66 114 750 .	09 66 114 650 .
	15	09 66 214 750 .	09 66 214 650 .
	25	09 66 314 750 .	09 66 314 650 .
	37	09 66 414 750 .	09 66 414 650 .
Please insert digit for flange thread or fitted female screw locks			
ø 3.1 mm hole ▶ 4 <sup>1)</sup>			
M3 ▶ 5			
4-40 UNC ▶ 6			
fitted screw locks 4-40 UNC ▶ 7 <sup>2)</sup>			
<b>Female connector</b> Flange height x = 6 mm			
metal shell	9	09 66 114 750 .	09 66 114 650 .
	15	09 66 214 750 .	09 66 214 650 .
	25	09 66 314 750 .	09 66 314 650 .
	37	09 66 414 750 .	09 66 414 650 .
	50	09 66 514 750 .	09 66 514 650 .
Please insert digit for flange thread or fitted female screw locks			
ø 3.1 mm hole ▶ 0 <sup>1)</sup>			
M3 ▶ 1			
4-40 UNC ▶ 2			
fitted screw locks 4-40 UNC ▶ 3 <sup>2)</sup>			

D-Sub

<sup>1)</sup> Not normally kept in stock  
<sup>2)</sup> Fitted screw locks 4-40 UNC not normally kept in stock for performance level 3  
 Connector dimensions see page 05.171. Mating conditions see page 05.167.

Number of contacts

# 9-50



Press-in, straight without grounding press-in board locks

Identification

Drawing

Dimensions in mm

**Male connector**  
9 – 25 contacts

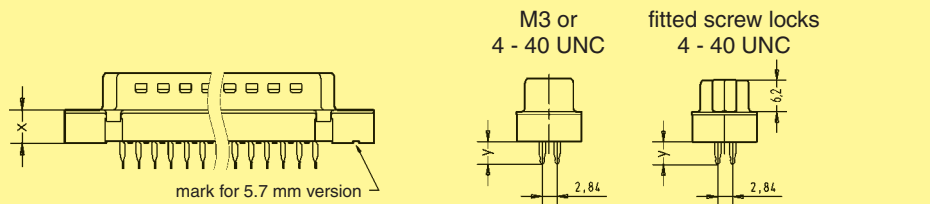

M3 or  
4 - 40 UNC

fitted screw locks  
4 - 40 UNC

Mating face acc. to: DIN 41 652 · CECC 75 301-802 · IEC 60 807

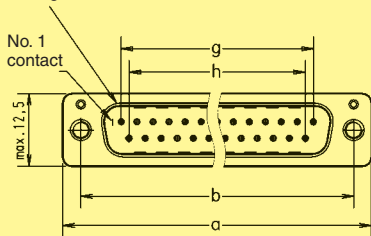

X	Y
6.0 ± 0.2	4.20 ± 0.2
5.7 ± 0.2	4.35 ± 0.2

**Female connector**  
9 – 37 contacts

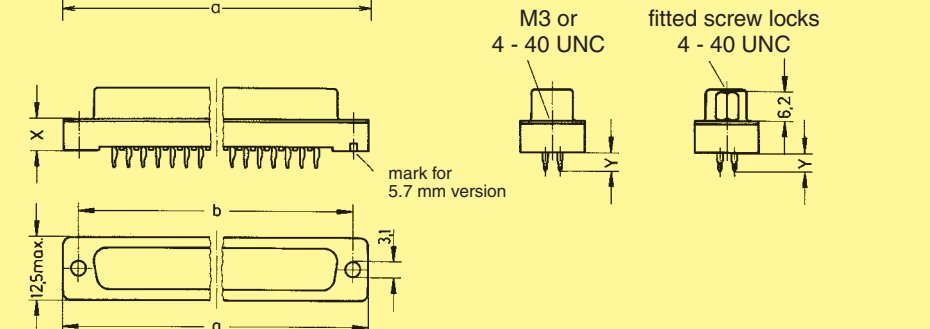

M3 or  
4 - 40 UNC

fitted screw locks  
4 - 40 UNC

**Female connector**  
50 contacts

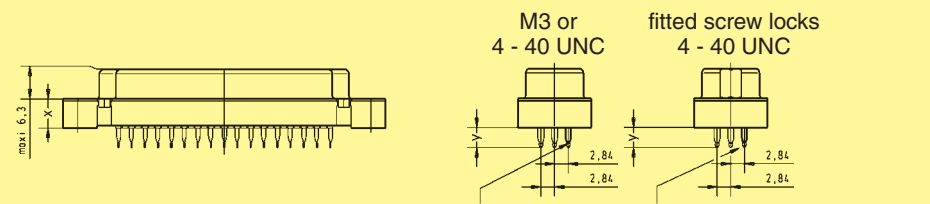

M3 or  
4 - 40 UNC

fitted screw locks  
4 - 40 UNC

Mating face acc. to: DIN 41 652 · CECC 75 301-802 · IEC 60 807

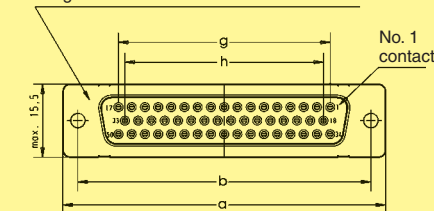

	a	b	g	h
9	31.00	24.90	4 x 2.74 = 10.96	3 x 2.74 = 8.22
15	39.30	33.20	7 x 2.74 = 19.18	6 x 2.74 = 16.44
25	53.10	47.00	12 x 2.76 = 33.12	11 x 2.76 = 30.36
37	69.65	63.55	18 x 2.76 = 49.68	17 x 2.76 = 46.92
50	67.00	61.10	16 x 2.76 = 44.16	15 x 2.76 = 41.40

Board drillings

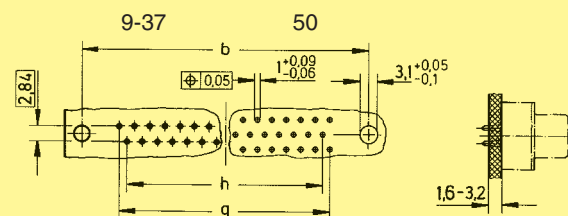

D-Sub

Number of contacts 9, 15, 25, 37  
UL recognized

Working current  
see current carrying capacity chart  
Stamped contacts 6.5 A max.

Test voltage  $U_{r.m.s.}$  1 kV

Clearance and creepage  $\geq 1.0$  mm

Contact resistance  $\leq 10$  m $\Omega$   
Insulation resistance  $\geq 10^{10}$   $\Omega$

Temperature range -55 °C ... + 125 °C  
during reflow soldering max. + 240 °C for 15 s  
The higher temperature limit includes the local ambient and heating effect of the contacts under load. All connectors are suitable for standard reflow processes.

Terminations  
a) Solder pins  $\varnothing$  0.6 mm for P.C.B. holes  $\varnothing$  0.8/1 mm  
b) Solder pins, angled 90°  $\varnothing$  0.6 mm for P.C.B. holes  $\varnothing$  1 mm

Materials  
Mouldings Thermoplastic resin, glass-fibre filled (PCT), UL 94-V0

Contacts Copper alloy

Contact surface  
Contact zone selectively gold-plated according to performance level<sup>1)</sup>

Metal shell Plated steel

Insertion and withdrawal force  
Connector on P.C.B.  
Solder, straight with clips  
– insertion max. per connector: 60 N  
– withdrawal min. per connector: 10 N

Mating force  
9 way  $\leq 30$  N  
15 way  $\leq 50$  N  
25 way  $\leq 83$  N  
37 way  $\leq 123$  N

Current carrying capacity

The current carrying capacity is limited by maximum temperature of materials for inserts and contacts including terminals.

The current capacity-curve is valid for continuous, not interrupted current-loaded-contacts of connectors when simultaneous power on all contacts is given, without exceeding the maximum temperature.

Control and test procedures according to DIN IEC 60 512.

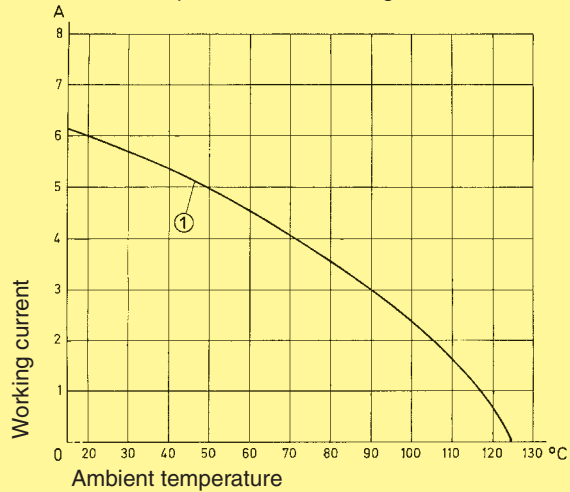

Example: 25 way connector

① Stamped contacts

Contact arrangement View from termination side

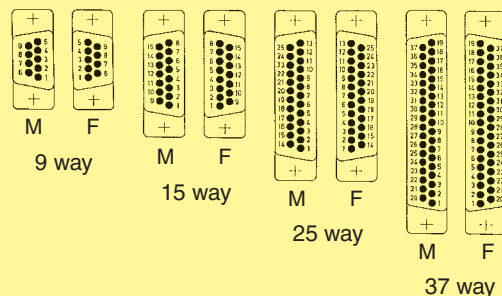

M = Male connector  
F = Female connector

Mating conditions as per DIN 41 652

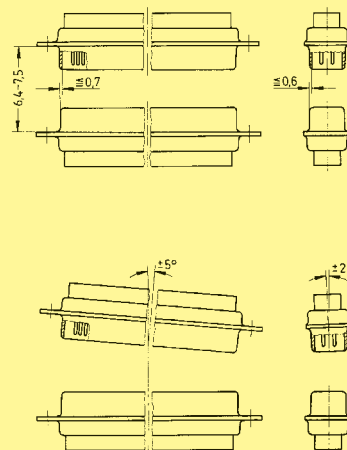

D-Sub

<sup>1)</sup> Performance level 3, 50 mating cycles, no gas test  
Performance level 2 as per CECC 75 301-802, 250 mating cycles, 4 days 4 mixed gas test – IEC 60 512  
Performance level 1 as per CECC 75 301-802, 500 mating cycles, 10 days 4 mixed gas test – IEC 60 512

Identification

Drawing

Dimensions in mm

**Standard Versions**

Mounting height 7.3 mm  
 9-37 way  
 for front panel  
 4 units of width (TE)

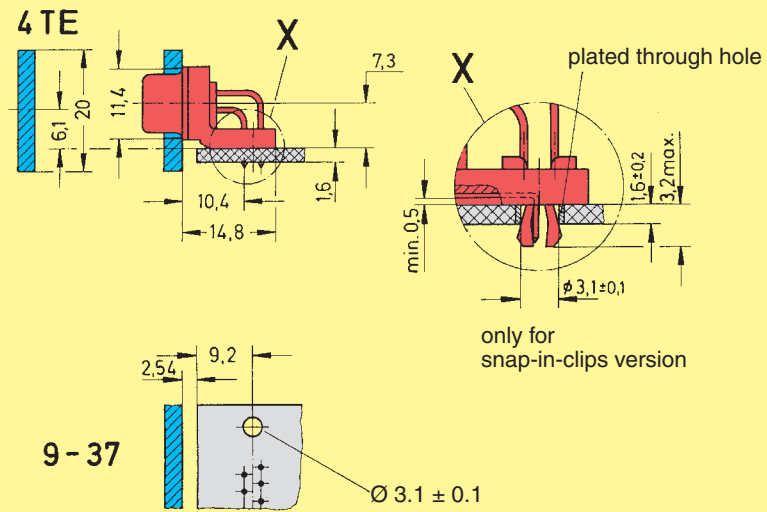

for connectors see pages 05.176 – 05.177

**Low-Profile Versions**

Mounting height 3.6 mm  
 9-37 way  
 for front panel  
 3 units of width (TE)

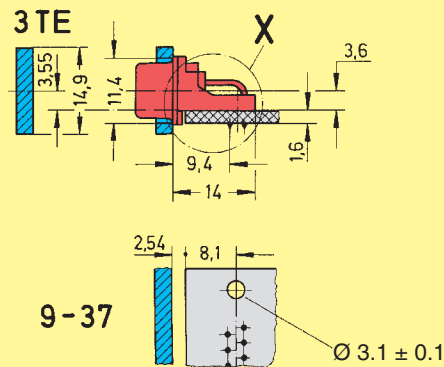

for connectors see pages 05.178 – 05.179

**Panel cut out for front/rear mount**

Values are taken from the CECC 75 301-802

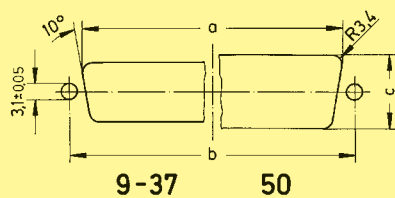

Front mount

	$a_{\pm 0.2}$	$b_{\pm 0.13}$	$c_{\pm 0.2}$
9	22.2	25.0	12.3
15	30.5	33.3	12.3
25	44.3	47.0	12.3
37	60.7	63.5	12.3
50	58.3	61.1	15.1

Rear mount

	$a_{\pm 0.2}$	$b_{\pm 0.13}$	$c_{\pm 0.2}$
9	20.5	25.0	11.4
15	28.8	33.3	11.4
25	42.5	47.0	11.4
37	59.1	63.5	11.4
50	56.3	61.1	14.1

D-Sub

Number of contacts

9-37



SMC stamped solder pins, straight with/without grounding board locks

Identification	No. of contacts	Part No.	
<b>Performance levels</b> Explanations see page 05.172 Other performance levels on request		Performance level 3	Performance level 2
<b>Male connector</b> metal shell with dimples			
Without grounding board locks	9 15 25 37	09 65 129 770 . 09 65 229 770 . 09 65 329 770 . 09 65 429 770 .	09 65 129 670 . 09 65 229 670 . 09 65 329 670 . 09 65 429 670 .
With grounding board locks	9 15 25 37	09 65 169 771 . 09 65 269 771 . 09 65 369 771 . 09 65 469 771 .	09 65 169 671 . 09 65 269 671 . 09 65 369 671 . 09 65 469 671 .
<b>Female connector</b> metal shell			
Without grounding board locks	9 15 25 37	09 66 115 750 . 09 66 215 750 . 09 66 315 750 . 09 66 415 750 .	09 66 115 650 . 09 66 215 650 . 09 66 315 650 . 09 66 415 650 .
With grounding board locks	9 15 25 37	09 66 155 751 . 09 66 255 751 . 09 66 355 751 . 09 66 455 751 .	09 66 155 651 . 09 66 255 651 . 09 66 355 651 . 09 66 455 651 .
Please insert digit for flange thread or fitted female screw locks			
M3 ▶ 1			
4-40 UNC ▶ 2			
fitted screw locks 4-40 UNC ▶ 3 <sup>1)</sup>			

D-Sub

<sup>1)</sup> Fitted screw locks 4-40 UNC not normally kept in stock for performance level 3  
 Connector dimensions see page 05.175. Mating conditions see page 05.172.

Number of contacts

**9-37**

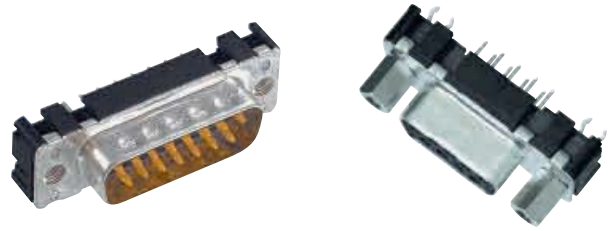

SMC stamped solder pins, straight with/without grounding board locks

Identification

Drawing

Dimensions in mm

Male connector

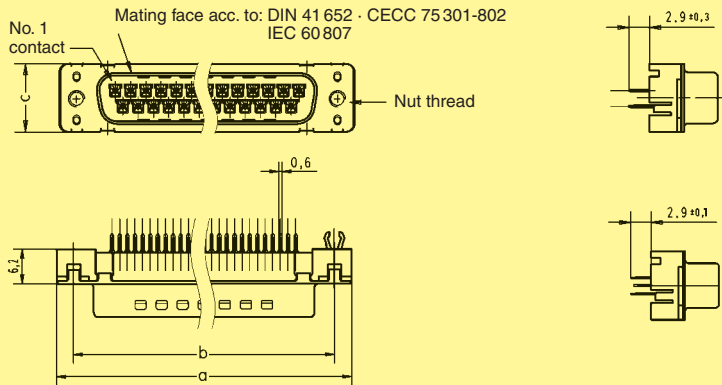

Female connector

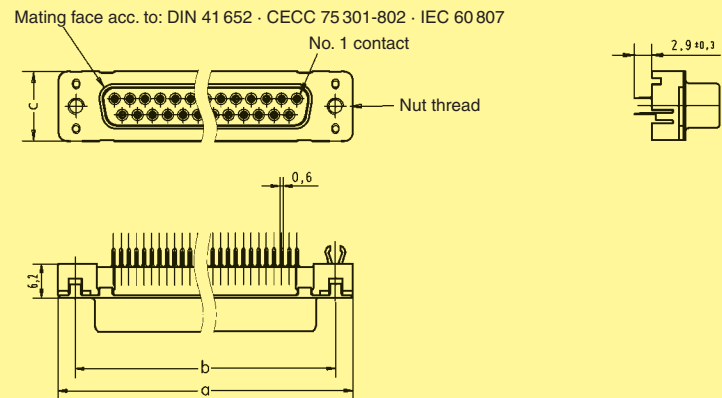

	a	b <sub>±0,1</sub>	c	g		h	
9	30.9	25.0	12.5	4 x	2.74 = 10.96	3 x	2.74 = 8.22
15	39.2	33.3	12.5	7 x	2.74 = 19.18	6 x	2.74 = 16.44
25	53.1	47.0	12.5	12 x	2.76 = 33.12	11 x	2.76 = 30.36
37	69.4	63.5	12.5	18 x	2.76 = 49.68	17 x	2.76 = 46.92

Board drillings

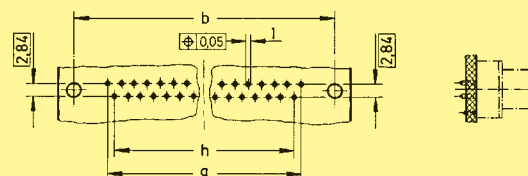



Number of contacts

Mounting height

9–37

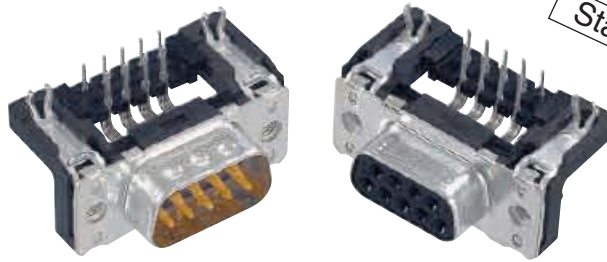
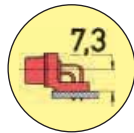

Standard Versions

SMC stamped solder pins, angled with grounding board locks

Identification	No. of contacts	Part No.			
<b>Performance levels</b> Explanations see page 05.172 Other performance levels on request		<b>Performance level 3</b>		<b>Performance level 2</b>	
<b>Male connector</b> metal shell with dimples		<b>2.84 mm pitch</b>		<b>2.84 mm pitch</b>	
	9	09 65 167 781 . 1)		09 65 167 681 . 1)	
	15	09 65 267 781 . 1)		09 65 267 681 . 1)	
	25	09 65 367 781 . 1)		09 65 367 681 . 1)	
	37	09 65 467 781 . 1)		09 65 467 681 . 1)	
		<b>2.54 mm pitch</b>		<b>2.54 mm pitch</b>	
	9	09 65 166 781 .		09 65 166 681 .	
	15	09 65 266 781 .		09 65 266 681 .	
	25	09 65 366 781 .		09 65 366 681 .	
	37	09 65 466 781 .		09 65 466 681 .	
<b>Female connector</b> metal shell		<b>2.84 mm pitch</b>		<b>2.84 mm pitch</b>	
	9	09 66 157 761 . 1)		09 66 157 661 . 1)	
	15	09 66 257 761 . 1)		09 66 257 661 . 1)	
	25	09 66 357 761 . 1)		09 66 357 661 . 1)	
	37	09 66 457 761 . 1)		09 66 457 661 . 1)	
		<b>2.54 mm pitch</b>		<b>2.54 mm pitch</b>	
	9	09 66 156 761 .		09 66 156 661 .	
	15	09 66 256 761 .		09 66 256 661 .	
	25	09 66 356 761 .		09 66 356 661 .	
	37	09 66 456 761 .		09 66 456 661 .	
Please insert digit for flange thread or fitted female screw locks					
Ø 3.1 mm hole ▶	0 <sup>1)</sup>				
M3 ▶	1				
4-40 UNC ▶	2				
fitted screw locks 4-40 UNC ▶	3				

D-Sub

<sup>1)</sup> Not normally kept in stock

Number of contacts

**9-37**

Mounting height

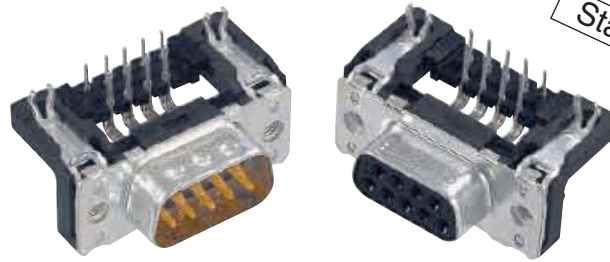
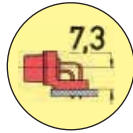

Standard Versions

SMC stamped solder pins, angled with grounding board locks

Identification

Drawing

Dimensions in mm

Male connector

Mating face acc. to: DIN 41 652 · CECC 75 301-802  
IEC 60 807

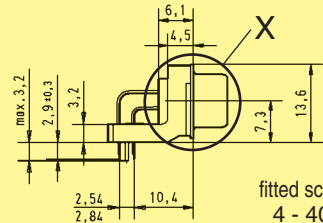
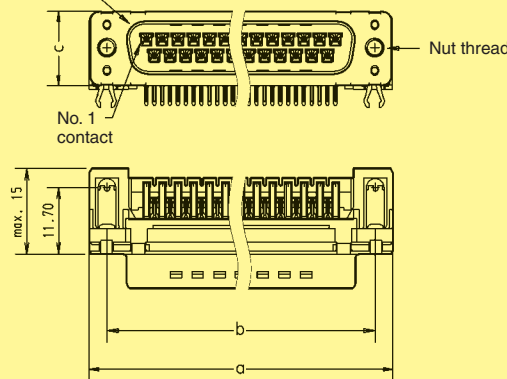

fitted screw locks  
4 - 40 UNC

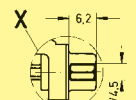

M3 or  
4 - 40 UNC

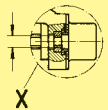

Female connector

Mating face acc. to: DIN 41 652 · CECC 75 301-802  
IEC 60 807

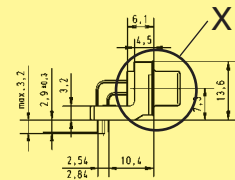
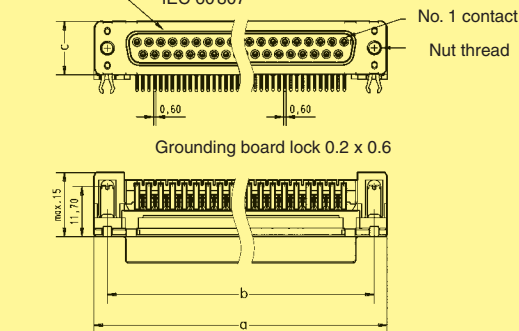

Board drillings

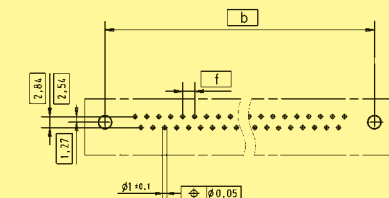

	a	b $\pm 0.1$	c	f
9	30.90	25.00	12.50	2.74
15	39.20	33.30	12.50	2.74
25	53.10	47.00	12.50	2.76
37	69.40	63.50	12.50	2.76

D-Sub

Number of contacts

Mounting height

9–37

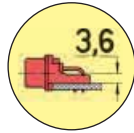

Low-Profile Versions

SMC stamped solder pins, angled with grounding board locks

Identification	No. of contacts	Part No.	
		Performance level 3	Performance level 2
<b>Performance levels</b> Explanations see page 05.172 Other contact surfaces on request			
<b>Male connector</b> metal shell with dimples	9	09 65 166 781 .	09 65 166 681 .
	15	09 65 266 781 .	09 65 266 681 .
	25	09 65 366 781 .	09 65 366 681 .
	37	09 65 466 781 .	09 65 466 681 .
<b>Female connector</b> metal shell	9	09 66 156 761 .	09 66 156 661 .
	15	09 66 256 761 .	09 66 256 661 .
	25	09 66 356 761 .	09 66 356 661 .
	37	09 66 456 761 .	09 66 456 661 .
Please insert digit for flange thread or fitted female screw locks			
M3 ▶	5		
4-40 UNC ▶	6		
fitted screw locks 4-40 UNC ▶	7		

D-Sub

Number of contacts

9-37

Mounting height

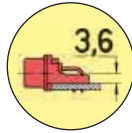

Low-Profile Versions

SMC stamped solder pins, angled with grounding board locks

Identification

Drawing

Dimensions in mm

Male connector

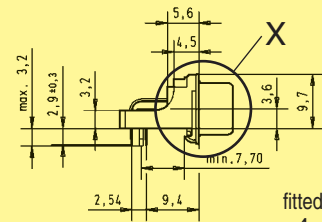
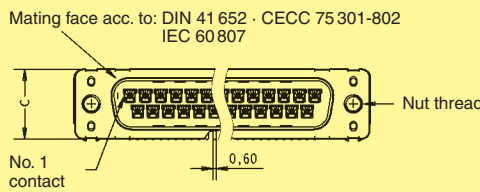

fitted screw locks  
4 - 40 UNC

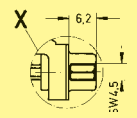

M3 or  
4 - 40 UNC

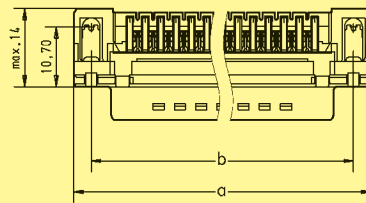
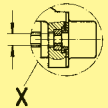

Female connector

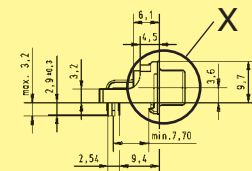
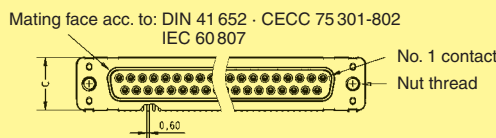

Grounding board lock 0.2 x 0.6

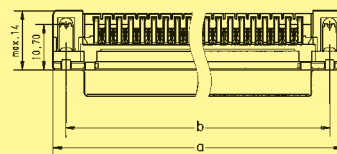

Board drillings

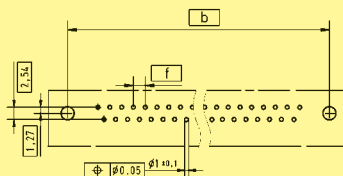

	a	b $\pm$ 0.1	c	f
9	30.90	25.00	12.50	2.74
15	39.20	33.30	12.50	2.74
25	53.10	47.00	12.50	2.76
37	69.40	63.50	12.50	2.76

D-Sub



Cable assemblies

Identification	Part No.	Drawing	Dimensions [mm]
<p><b>Cable assembly D-Sub HD 78 pole</b></p> <p>Hood: shielded plastic hood with side entry, screw 4-40 UNC</p> <p>Cable: 39 twisted pairs, AWG 26, double shielded, PVC</p> <p>Wiring: 1:1</p> <p>Length: L = 0.5 m                      L = 1.0 m                      L = 2.0 m                      L = 5.0 m                      L = 10.0 m                      L = 20.0 m</p>	<p>33 56 212 0050 028                      33 56 213 1000 002                      33 56 213 2000 016                      33 56 212 0500 029                      33 56 212 1000 030                      33 56 212 2000 031</p>		
<p><b>Cable assembly D-Sub HD 44 pole</b></p> <p>Hood: shielded plastic hood with side entry, screw 4-40 UNC</p> <p>Cable: 22 twisted pairs, AWG 26, double shielded, PVC</p> <p>Wiring: 1:1</p> <p>Length: L = 0.5 m                      L = 1.0 m                      L = 1.5 m                      L = 2.0 m                      L = 5.0 m                      L = 10.0 m</p>	<p>33 56 213 0500 023                      33 56 213 1000 024                      33 56 213 1500 022                      33 56 213 2000 025                      33 56 213 5000 026                      33 56 212 1000 027</p>		
<p><b>Cable assembly D-Sub HD 44 pole</b></p> <p>Hood: metal hood with top entry, screw 4-40 UNC</p> <p>Cable: 24 twisted pairs, AWG 26, double shielded, PVC</p> <p>Wiring: 1:1</p> <p>Length: L = 0.5 m                      L = 1.0 m                      L = 5.0 m                      L = 10.0 m                      L = 20.0 m</p>	<p>33 56 212 0050 032                      33 56 212 0100 033                      33 56 212 0500 034                      33 56 212 1000 035                      33 56 212 2000 036</p>		

D-Sub

Identification	No. of contacts	Part No.	Drawing	Dimensions in mm												
Flat cable AWG 28/7	9 15 25 37	09 18 009 700 <input type="checkbox"/> <sup>1)</sup> 09 18 015 700 <input type="checkbox"/> <sup>1)</sup> 09 18 025 700 <input type="checkbox"/> <sup>1)</sup> 09 18 037 700 <input type="checkbox"/> <sup>1)</sup>	<p>grey</p> <p>UL AWM-style 2651</p>	<p>colour coded</p> <p>AWG 28/7</p> <p>UL AWM-style 20130</p>												
					grey 30.48 m 1											
					grey 100 m 4											
					colour coded 30.48 m 5											
Round flat cable AWG 28/7	9 15 25 37	09 18 009 70 <input type="checkbox"/> <sup>1)</sup> 09 18 015 70 <input type="checkbox"/> <sup>1)</sup> 09 18 025 70 <input type="checkbox"/> <sup>1)</sup> 09 18 037 70 <input type="checkbox"/> <sup>1)</sup>	<p>Slit section</p> <p>① Flat cable, AWG 28/7 ② Aluminium / Polyester tape (spiral wrap) ③ 85 % minimum coverage tinned copper braid ④ Paper line ⑤ Outer jacket: black PVC</p> <p>Edge mark on first conductor</p> <p>0,64 ± 0,13</p> <p>1,27 ± 0,08</p> <p>AWG 28/7</p> <p>grey</p> <p>0,89 ± 0,08</p> <p>Drawing shows a round flat cable with screening.</p>	<table border="1"> <thead> <tr> <th>No. of contacts</th> <th>a</th> <th>b</th> <th>c</th> </tr> </thead> <tbody> <tr> <td>6 to 26</td> <td>19.05</td> <td>19.05</td> <td>38.10</td> </tr> <tr> <td>34 to 64</td> <td>38.10</td> <td>19.05</td> <td>57.15</td> </tr> </tbody> </table>	No. of contacts	a	b	c	6 to 26	19.05	19.05	38.10	34 to 64	38.10	19.05	57.15
					No. of contacts	a	b	c								
					6 to 26	19.05	19.05	38.10								
					34 to 64	38.10	19.05	57.15								
					with screening 30.48 m 07											
without screening 30.48 m 08																
with screening 100 m 10																
without screening 100 m 11																

D-Sub

<sup>1)</sup> Not available in colour coded version